

**EANCOM 2002 Syntax 3**  
**Edition 2016\_Update 2021**

Direct debit message  
(DIRDEB)

Introduction.....	2
Branching Diagram .....	5
Message Structure.....	17
Segmentlayout.....	19
Codes .....	117
Example.....	375

## Einführung

---

### Introduction

The following message specification is based on the publication of the "Direct Debit Message" of GS1 Global in syntax 3.

#### Status

MESSAGE TYPE: DERDEB  
REFERENCE DIRECTORY: D.01B  
EANCOM® SUBSET VERSION: 003

#### Definition

A Direct Debit is sent by the Creditor to the Creditor's Bank instructing it to claim specified amount(s) from the Debtor(s) and to credit the amount(s) to an account specified in the message, which the Creditor's Bank services for the Creditor in settlement of the referenced transaction(s).

**Note:** Throughout this document the term 'Creditor' refers to either a Beneficiary, Payee or Supplier, likewise the term 'Debtor' refers to either an Ordering Customer, Payor, or Buyer.

Prior to the Direct Debit procedure, some agreement(s) would usually have been concluded:

- agreement between the Creditor and his Bank (mainly to specify the conditions of credit and the kind of direct debit).
- agreement between the Debtor and the Debtor's Bank (i.e. pre-authorisation and condition of debit), or between the Creditor and the Debtor.

The term 'pre-authorisation' refers to an agreement between a Creditor and a Debtor for:

- either automatic debiting, as required,
- or for debiting unless rejected by the debtor in a period of time.

The agreement can also be made between the debtor and his bank, independently of the amount of the DIRDEB.

#### Principles

The message may be used as a delivery schedule by the buyer to:

- A Direct Debit may cover the financial settlement(s) of one or more commercial trade transactions, such as invoices, credit notes, debit notes, etc.
- Several credit accounts, execution dates and currencies may be specified.
- Charges may be borne on account(s) different of the account(s) held by the Creditor.
- The Creditor's Bank may need a confirmation/authorisation from the creditor to be able to process

## Einführung

---

the Direct Debit Message.

- Pre-authorised and non pre-authorised direct debits shall not be mixed within the same message.
- The only way to modify a Direct Debit message is to cancel the whole message or a transaction thereof (e.g. by the use of the FINCAN message). In that respect, one to many order(s) could be cancelled within the message, avoiding to be obliged to cancel the whole message.
- The originator of the message can only effect the cancellation of a Direct Debit message. The kind of cancellation is dependent upon the process of the message or a transaction of it.

### Notes

The Multiple Direct Debit message is structured in three levels: A, B, and C.

#### Level A

Header Section - This section, A, contains general data related to the whole message and is contained in Segment Groups 1, 2, 3 and 24.

#### Level B

Credit Side Detail - This section, B, contains batches of data. Each batch is organised from the credit side's perspective, i.e. one credit account, one currency, one execution day and one credit batch total amount. Each batch then contains detailed data which applies to all the dependent C levels, i.e. the individual direct debit transactions, and is contained in Segment Group 4 through Segment Group 10.

#### Level C

Direct Debit Detail - This section, C, contains data related to the debit side, i.e. the individual direct debit transactions. The data is a unique set for each direct debit transaction and is contained in Segment Group 11 through Segment Group 23. There can be one or many individual transactions within each batch.

The structure of the message is designed to allow several B level batches, each being followed by one or more related C level transactions. Each C level is followed by its associated remittance details.

### Scenario

While the Direct Debit message is similar in content to the Multiple Payment Order (PAYMUL) message, it is very different in application. The Multiple Payment Order message is sent by an ordering party (normally the payer or buyer) to instruct its bank to effect a payment to a names beneficiary or beneficiaries (payee or supplier). The Direct Debit message is almost a complete inversion of this scenario.

The Direct Debit message is sent by a Creditor (beneficiary/payee/supplier) to its bank instructing the bank to collect funds from the account of a Debtor (payer/buyer). The Direct Debit message will normally be subject to a Direct Debit Mandate. A Direct Debit Mandate is an agreement between the Creditor and the Debtor, which allows the Creditor to demand payment from the bank of the Debtor.

## Einführung

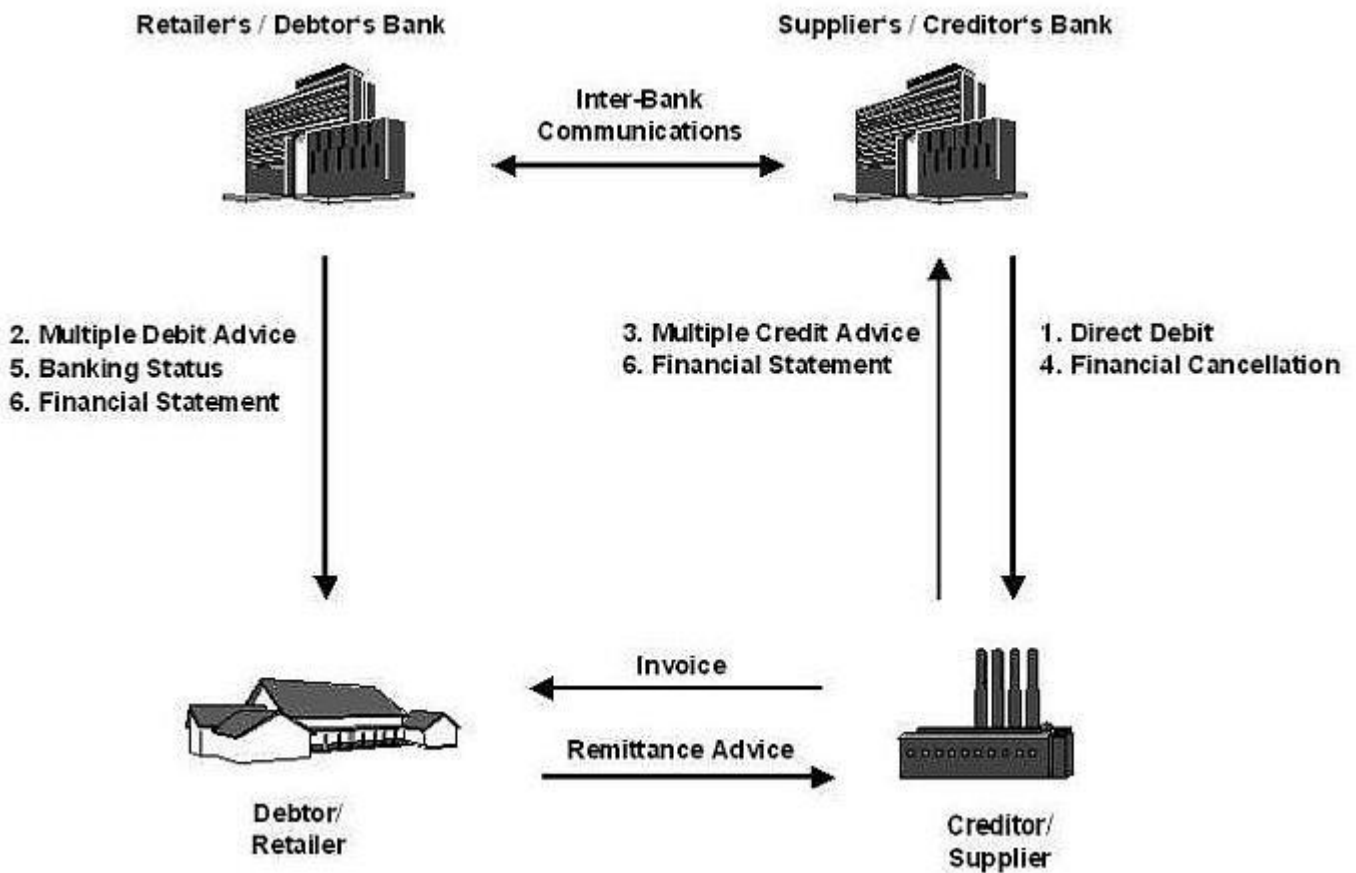

The processes which follow the Direct Debit are the same as those which occur after a Multiple Payment Order message, i.e., debiting of the debtors account is reported to the debtor using the Multiple Debit Advice (DEBMUL) message, crediting of the Creditor's account is reported to the creditor using the Multiple Credit Advice (CREMUL) message, etc.

### Branching Diagram

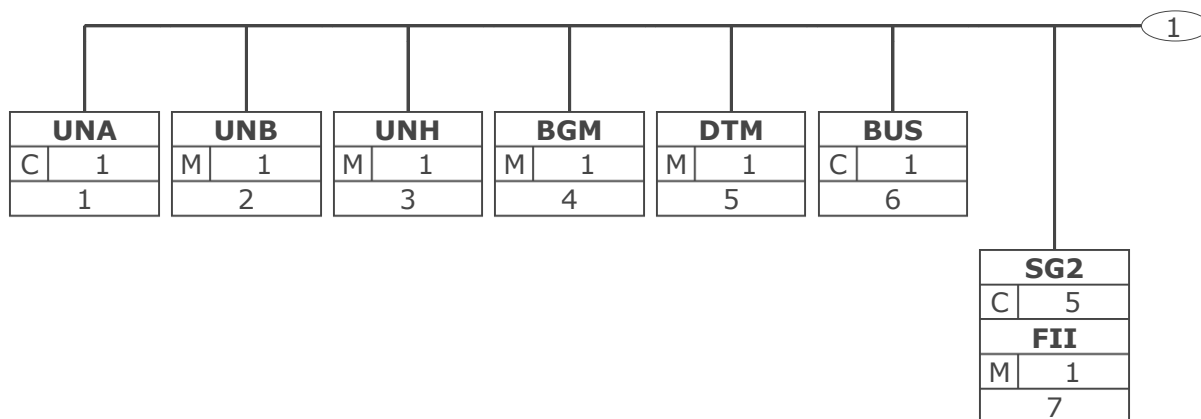

Tag	Tag = Segment/Group Tag	
St	MaxOcc	St = Status (M=Mandatory, C=Conditional, R=Required, O=Optional, A=Advised, D=Dependent)
No	MaxOcc	MaxOcc = Maximum occurrence of the segment/group; No = Consecutive segment number

## Branching Diagram

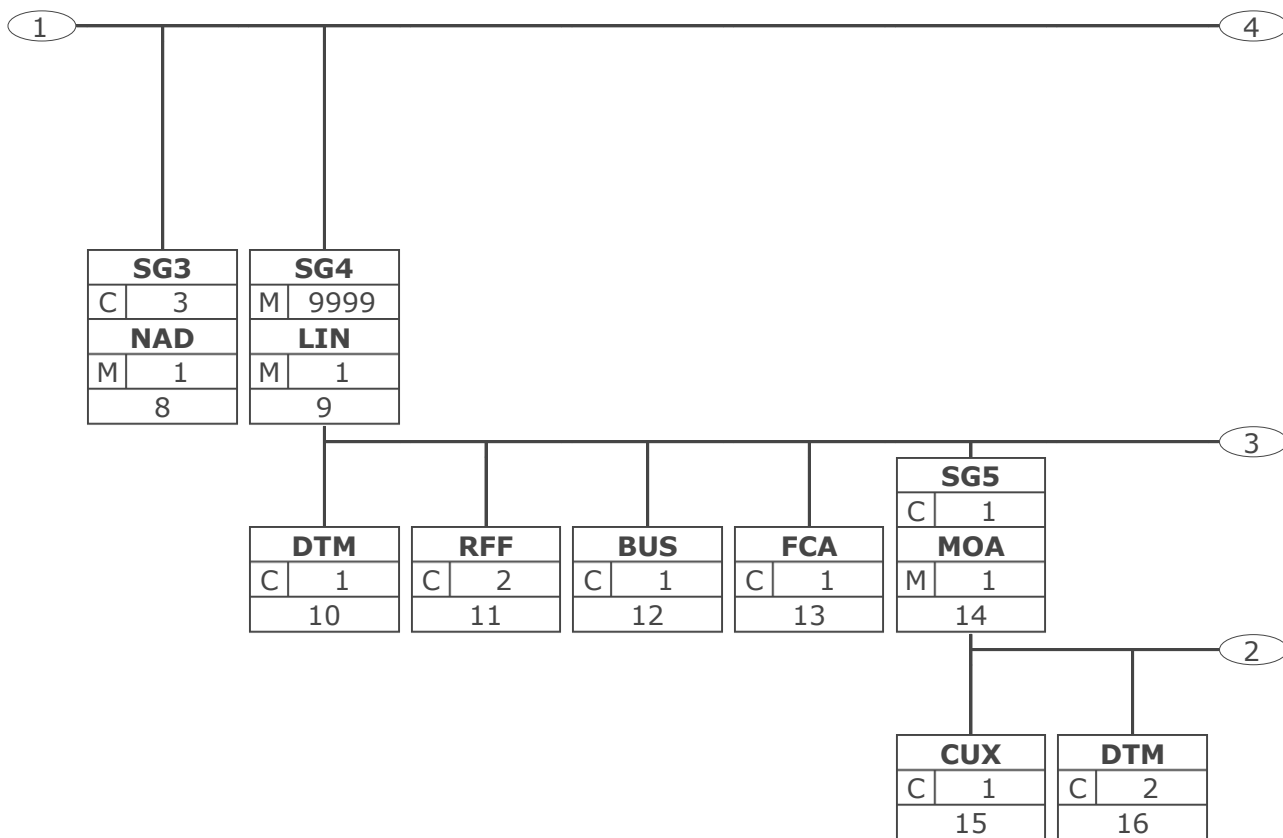

Tag	Tag = Segment/Group Tag
St   MaxOcc	St = Status (M=Mandatory, C=Conditional, R=Required, O=Optional, A=Advised, D=Dependent)
No	MaxOcc = Maximum occurrence of the segment/group; No = Consecutive segment number

## Branching Diagram

---

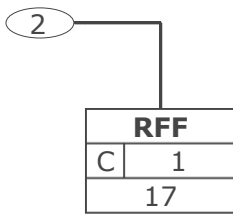

Tag	Tag = Segment/Group Tag	
St	MaxOcc	St = Status (M=Mandatory, C=Conditional, R=Required, O=Optional, A=Advised, D=Dependent)
No	MaxOcc = Maximum occurrence of the segment/group; No = Consecutive segment number	

### Branching Diagram

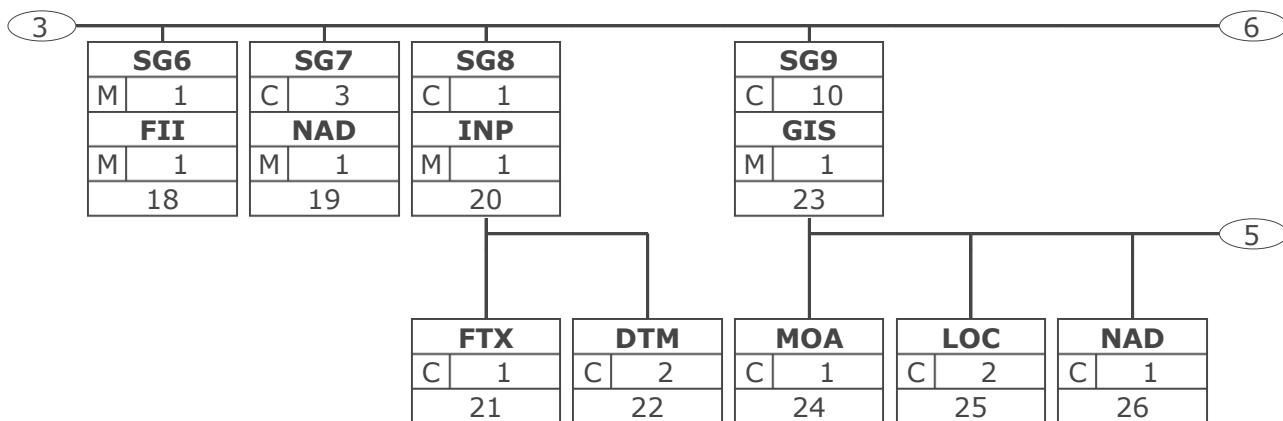

Tag	Tag = Segment/Group Tag
St	MaxOcc St = Status (M=Mandatory, C=Conditional, R=Required, O=Optional, A=Advised, D=Dependent)
No	MaxOcc = Maximum occurrence of the segment/group; No = Consecutive segment number



## Branching Diagram

---

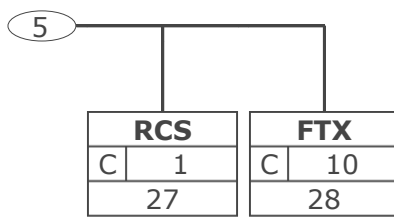

Tag	Tag = Segment/Group Tag
St   MaxOcc	St = Status (M=Mandatory, C=Conditional, R=Required, O=Optional, A=Advised, D=Dependent)
No	MaxOcc = Maximum occurrence of the segment/group; No = Consecutive segment number

## Branching Diagram

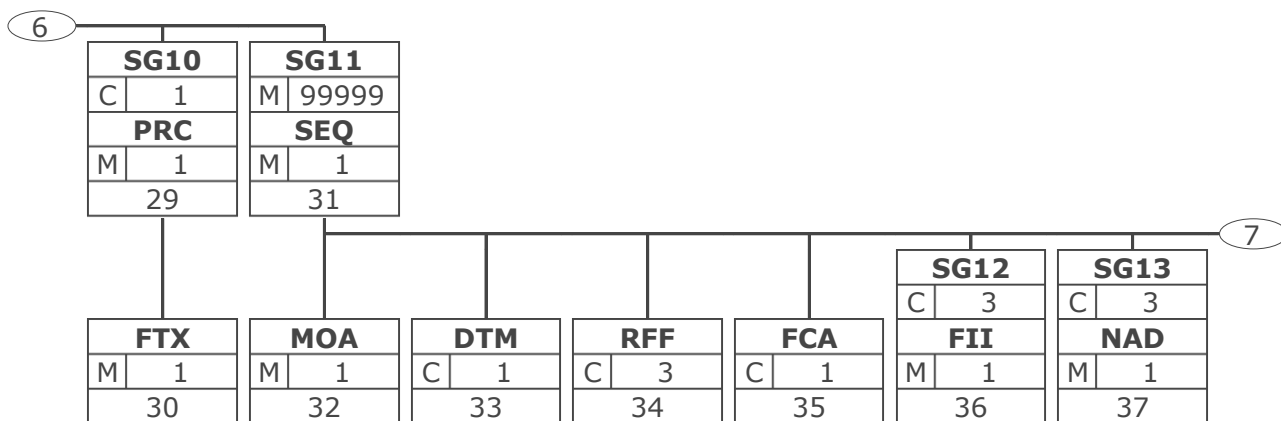

Tag	Tag = Segment/Group Tag
St   MaxOcc	St = Status (M=Mandatory, C=Conditional, R=Required, O=Optional, A=Advised, D=Dependent)
No	MaxOcc = Maximum occurrence of the segment/group; No = Consecutive segment number

## Branching Diagram

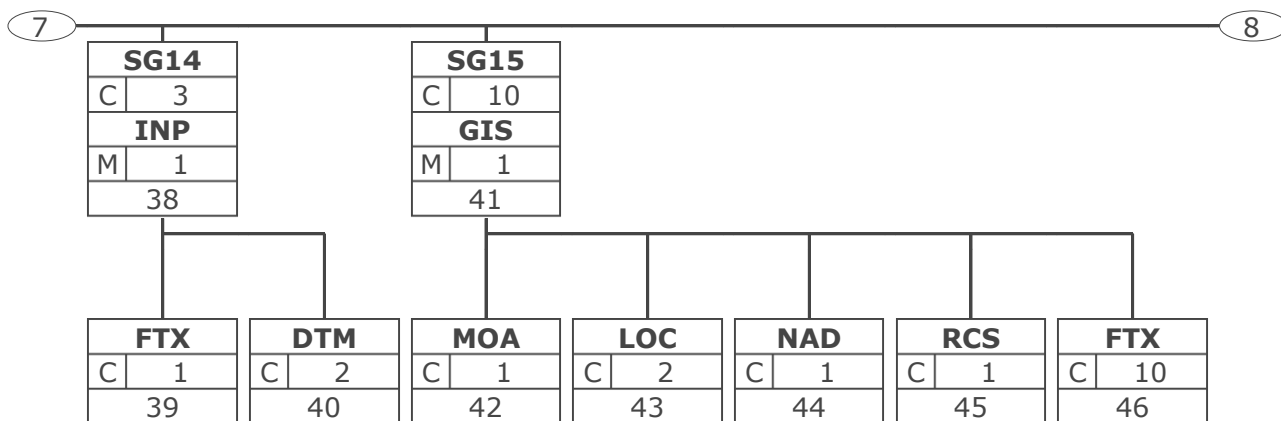

Tag	Tag = Segment/Group Tag
St	MaxOcc St = Status (M=Mandatory, C=Conditional, R=Required, O=Optional, A=Advised, D=Dependent)
No	MaxOcc = Maximum occurrence of the segment/group; No = Consecutive segment number

## Branching Diagram

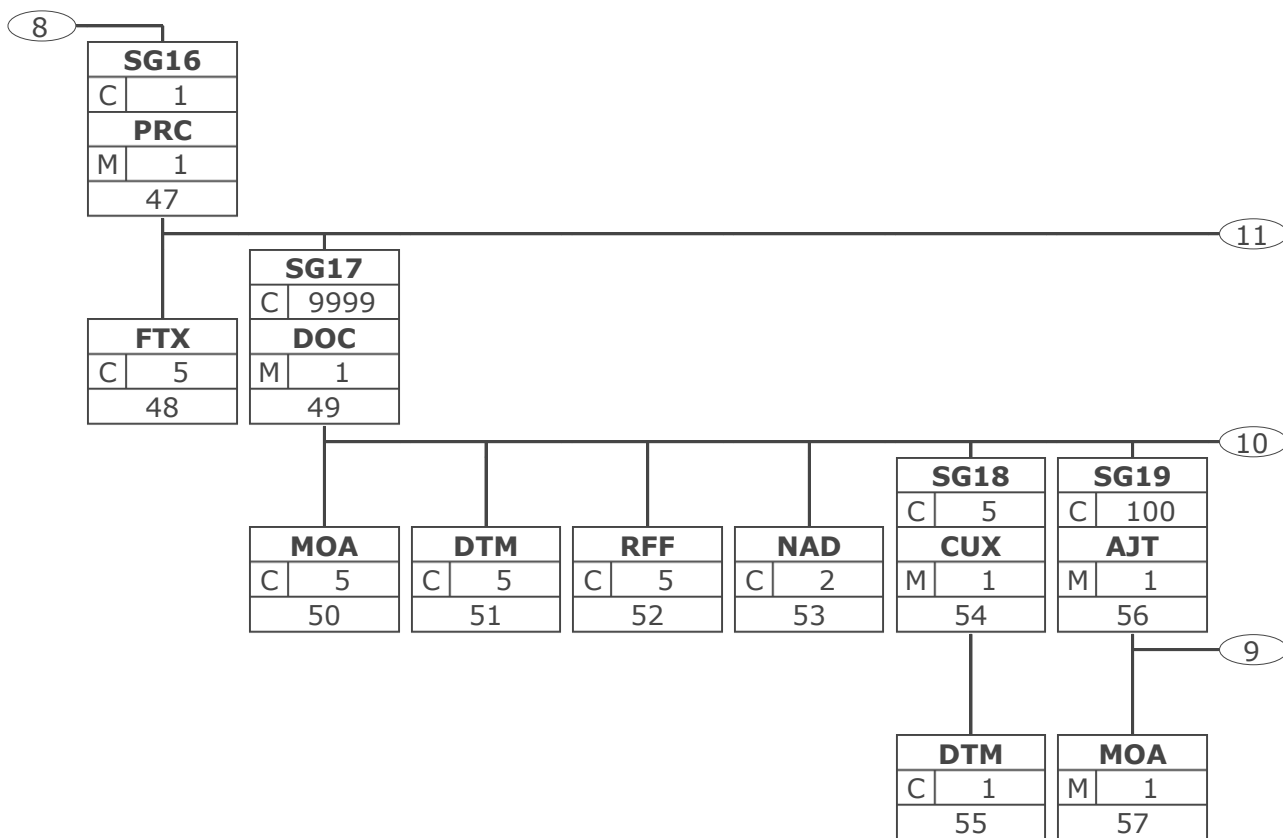

Tag	Tag = Segment/Group Tag
St   MaxOcc	St = Status (M=Mandatory, C=Conditional, R=Required, O=Optional, A=Advised, D=Dependent)
No	MaxOcc = Maximum occurrence of the segment/group; No = Consecutive segment number

## Branching Diagram

---

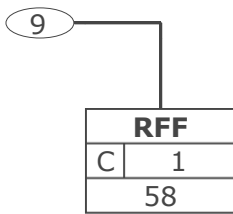

Tag	Tag = Segment/Group Tag
St	MaxOcc St = Status (M=Mandatory, C=Conditional, R=Required, O=Optional, A=Advised, D=Dependent)
No	MaxOcc = Maximum occurrence of the segment/group; No = Consecutive segment number

## Branching Diagram

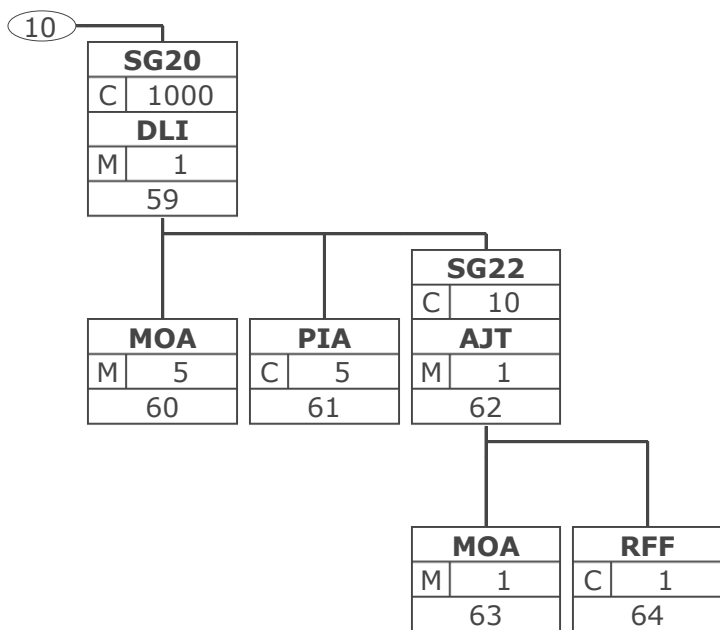

Tag	Tag = Segment/Group Tag
St   MaxOcc	St = Status (M=Mandatory, C=Conditional, R=Required, O=Optional, A=Advised, D=Dependent)
No	MaxOcc = Maximum occurrence of the segment/group; No = Consecutive segment number

## Branching Diagram

---

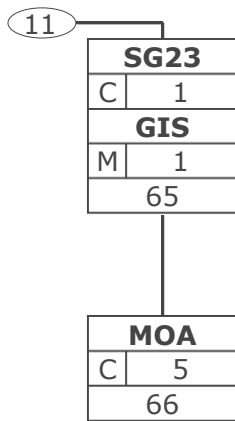

Tag	Tag = Segment/Group Tag
St   MaxOcc	St = Status (M=Mandatory, C=Conditional, R=Required, O=Optional, A=Advised, D=Dependent)
No	MaxOcc = Maximum occurrence of the segment/group; No = Consecutive segment number

## Branching Diagram

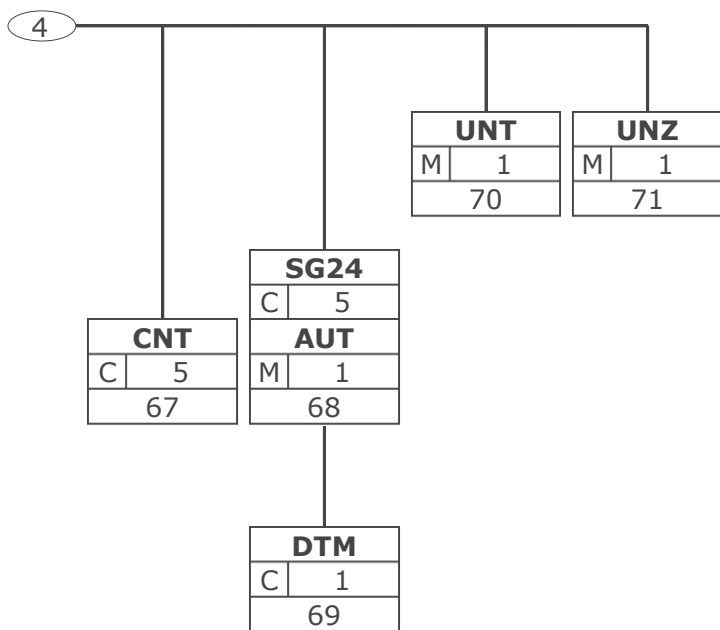

Tag	Tag = Segment/Group Tag
St   MaxOcc	St = Status (M=Mandatory, C=Conditional, R=Required, O=Optional, A=Advised, D=Dependent)
No	MaxOcc = Maximum occurrence of the segment/group; No = Consecutive segment number



**Message Structure**

Seg.	No.	Status	Max Occ	Segment
UNA	1	C	1	Service string advice
UNB	2	M	1	Interchange header
<b>Direct Debit Heading Section</b>				
UNH	3	M	1	Message header
BGM	4	M	1	Beginning of message
DTM	5	M	1	Date/time/period
BUS	6	C	1	Business function
SG2		C	5	FII
FII	7	M	1	Financial institution information
SG3		C	3	NAD
NAD	8	M	1	Name and address
<b>Direct Debit Detail Section</b>				
SG4		M	9999	LIN-DTM-RFF-BUS-FCA-SG5-SG6-SG7-SG8-SG9-SG10-SG11
LIN	9	M	1	Line item
DTM	10	C	1	Date/time/period
RFF	11	C	2	Reference
BUS	12	C	1	Business function
FCA	13	C	1	Financial charges allocation
SG5		C	1	MOA-CUX-DTM-RFF
MOA	14	M	1	Monetary amount
CUX	15	C	1	Currencies
DTM	16	C	2	Date/time/period
RFF	17	C	1	Reference
SG6		M	1	FII
FII	18	M	1	Financial institution information
SG7		C	3	NAD
NAD	19	M	1	Name and address
SG8		C	1	INP-FTX-DTM
INP	20	M	1	Parties and instruction
FTX	21	C	1	Free text
DTM	22	C	2	Date/time/period
SG9		C	10	GIS-MOA-LOC-NAD-RCS-FTX
GIS	23	M	1	General indicator
MOA	24	C	1	Monetary amount
LOC	25	C	2	Place/location identification
NAD	26	C	1	Name and address
RCS	27	C	1	Requirements and conditions
FTX	28	C	10	Free text
SG10		C	1	PRC-FTX
PRC	29	M	1	Process identification
FTX	30	M	1	Free text
SG11		M	99999	SEQ-MOA-DTM-RFF-FCA-SG12-SG13-SG14-SG15-SG16
SEQ	31	M	1	Sequence details
MOA	32	M	1	Monetary amount
DTM	33	C	1	Date/time/period
RFF	34	C	3	Reference
FCA	35	C	1	Financial charges allocation
SG12		C	3	FII

Max. Occ. = Maximum occurrence of the segment/group, Status: M=Mandatory, C=Conditional, R=Required, O=Optional, A=Advised, D=Dependent

**Message Structure**

Seg.	No.	Status	Max Occ	Segment
FII	36	M	1	Financial institution information
SG13		C	3	NAD
NAD	37	M	1	Name and address
SG14		C	3	INP-FTX-DTM
INP	38	M	1	Parties and instruction
FTX	39	C	1	Free text
DTM	40	C	2	Date/time/period
SG15		C	10	GIS-MOA-LOC-NAD-RCS-FTX
GIS	41	M	1	General indicator
MOA	42	C	1	Monetary amount
LOC	43	C	2	Place/location identification
NAD	44	C	1	Name and address
RCS	45	C	1	Requirements and conditions
FTX	46	C	10	Free text
SG16		C	1	PRC-FTX-SG17-SG23
PRC	47	M	1	Process identification
FTX	48	C	5	Free text
SG17		C	9999	DOC-MOA-DTM-RFF-NAD-SG18-SG19-SG20
DOC	49	M	1	Document/message details
MOA	50	C	5	Monetary amount
DTM	51	C	5	Date/time/period
RFF	52	C	5	Reference
NAD	53	C	2	Name and address
SG18		C	5	CUX-DTM
CUX	54	M	1	Currencies
DTM	55	C	1	Date/time/period
SG19		C	100	AJT-MOA-RFF
AJT	56	M	1	Adjustment details
MOA	57	M	1	Monetary amount
RFF	58	C	1	Reference
SG20		C	1000	DLI-MOA-PIA-SG22
DLI	59	M	1	Document line identification
MOA	60	M	5	Monetary amount
PIA	61	C	5	Additional product id
SG22		C	10	AJT-MOA-RFF
AJT	62	M	1	Adjustment details
MOA	63	M	1	Monetary amount
RFF	64	C	1	Reference
SG23		C	1	GIS-MOA
GIS	65	M	1	General indicator
MOA	66	C	5	Monetary amount
<b>Direct Debit Summary Section</b>				
CNT	67	C	5	Control total
SG24		C	5	AUT-DTM
AUT	68	M	1	Authentication result
DTM	69	C	1	Date/time/period
UNT	70	M	1	Message trailer
UNZ	71	M	1	Interchange trailer

Max. Occ. = Maximum occurrence of the segment/group, Status: M=Mandatory, C=Conditional, R=Required, O=Optional, A=Advised, D=Dependent

## Segment Layout

No. Seg	St	Max. Occ.				
1	<b>UNA</b>	C 1	Service string advice			
To define the characters selected for use as delimiters and indicators in the rest of the interchange that follows.						
Business Term	DE	EDIFACT	Format	St	*	Description
	UNA1	Component data element separator	an1	M	*	Used as a separator between component data elements contained within a composite data element (default value: ":")
	UNA2	Data element separator	an1	M	*	Used to separate two simple or composite data elements (default value: "+" )
	UNA3	Decimal notation	an1	M	*	Used to indicate the character used for decimal notation (default value: ".")
	UNA4	Release indicator	an1	M	*	Used to restore any service character to its original specification (value: "?").
	UNA5	Reserved for future use	an1	M	*	(default value: space )
	UNA6	Segment terminator	an1	M	*	Used to indicate the end of segment data (default value: "'")
<p>The service string advice shall begin with the upper case characters UNA immediately followed by six characters in the order shown below. The same character shall not be used in more than one position of the UNA.</p> <p>This segment is used to inform the receiver of the interchange that a set of service string characters which are different to the default characters are being used.</p> <p>When using the default set of service characters, the UNA segment need not be sent. If it is sent, it must immediately precede the UNB segment and contain the four service string characters (positions UNA1, UNA2, UNA4 and UNA6) selected by the interchange sender.</p> <p>Regardless of whether or not all of the service string characters are being changed every data element within this segment must be filled, (i.e., if some default values are being used with user defined ones, both the default and user defined values must be specified).</p> <p>When expressing the service string characters in the UNA segment, it is not necessary to include any element separators.</p> <p>The use of the UNA segment is required when using a character set other than level A.</p> <p>Example: UNA:+.?' '</p> <p>Example: UNA:+.?' '</p>						

Max. Occ. = Maximum Occurrence, St = Status, \* = Restricted Codes

Status: M=Mandatory, R=Required, O=Optional, C=Conditional, D=Dependent, A=Advised, N=Not used

**Segment Layout**

No. Seg	St	Max. Occ.			
2	<b>UNB</b>	M 1	Interchange header To start, identify and specify an interchange.		
Business Term	DE	EDIFACT	Format	St	* Description
	S001	Syntax identifier		M	See Part I chapter 5.2.7 and segment notes.
	0001	Syntax identifier	a4	M	* UNOA UN/ECE level A UNOB UN/ECE level B UNOC UN/ECE level C UNOD UN/ECE level D UNOE UN/ECE level E UNOF UN/ECE level F
	0002	Syntax version number	n1	M	* 3 Version 3
	S002	Interchange sender		M	
	0004	Sender identification	an..35	M	GLN (n13)
	0007	Partner identification code qualifier	an..4	R	* 14 GS1
	0008	Address for reverse routing	an..14	O	
	S003	Interchange recipient		M	
	0010	Recipient identification	an..35	M	GLN (n13)
	0007	Partner identification code qualifier	an..4	R	* 14 GS1
	0014	Routing address	an..14	O	
	S004	Date/time of preparation		M	
	0017	Date of preparation	n6	M	YYMMDD
	0019	Time of preparation	n4	M	HHMM
	0020	Interchange control reference	an..14	M	Unique reference identifying the interchange. Created by the interchange sender.
	S005	Recipient's reference, password		O	
	0022	Recipient's reference/ password	an..14	M	
	0025	Recipient's reference/ password qualifier	an2	O	
	0026	Application reference	an..14	O	Message identification if the interchange contains only one type of message.
	0029	Processing priority code	a1	O	A Highest priority
	0031	Acknowledgement request	n1	O	1 Requested
	0032	Communications agreement ID	an..35	O	* EANCOM.....
	0035	Test indicator	n1	O	1 Interchange is a test

Max. Occ. = Maximum Occurrence, St = Status, \* = Restricted Codes

Status: M=Mandatory, R=Required, O=Optional, C=Conditional, D=Dependent, A=Advised, N=Not used

## Segment Layout

This segment is used to envelope the interchange, as well as to identify both, the party to whom the interchange is sent and the party who has sent the interchange. The principle of the UNB segment is the same as a physical envelope which covers one or more letters or documents, and which details, both the address where delivery is to take place and the address from where the envelope has come.

S001: The character encoding specified in basic code table of ISO/IEC 646 (7-bit coded character set for information interchange) shall be used for the interchange service string advice (if used) and up to and including the composite data element S001 'Syntax identifier' in the interchange header. The character repertoire used for the characters in an interchange shall be identified from the code value of data element 0001 in S001 'Syntax identifier' in the interchange header. The character repertoire identified does not apply to objects and/or encrypted data.

The default encoding technique for a particular repertoire shall be the encoding technique defined by its associated character set specification.

DE 0001: The recommended (default) character set for use in EANCOM® for international exchanges is character set A (UNOA). Should users wish to use character sets other than A, an agreement on which set to use should be reached on a bilateral basis before communications begin.

DE 0004, 0008, 0010, 0014, 0042 and 0046: Within EANCOM® the use of the Global Location Number (GLN) is recommended for the identification of the interchange sender and recipient.

DE 0008: Identification (e.g. a division) specified by the sender of the interchange, to be included if agreed, by the recipient in response interchanges, to facilitate internal routing.

DE 0042: Sub-level of sender internal identification, when further sub-level identification is required.

DE 0014: The address for routing, provided beforehand by the interchange recipient, is used by the interchange sender to inform the recipient of the internal address, within the latter's systems, to which the interchange should be routed. It is recommended that the GLN be used for this purpose.

DE 0007: Identification (e.g. a division) specified by the recipient of the interchange, to be included if agreed, by the sender in response interchanges, to facilitate internal routing.

DE 0046: Sub-level of recipient internal identification, when further sub-level identification is required.

DE S004: The date and time specified in this composite should be the date and time at which the interchange sender prepared the interchange. This date and time may not necessarily be the same as the date and time of contained messages.

DE 0020: The interchange control reference number is generated by the interchange sender and is used to identify uniquely each interchange. Should the interchange sender wish to re-use interchange control reference numbers, it is recommended that each number be preserved for at least a period of three months before being re-used. In order to guarantee uniqueness, the interchange control reference number should always be linked to the interchange sender's identification (DE 0004).

DE S005: The use of passwords must first be agreed bilaterally by the parties exchanging the interchange.

DE 0026: This data element is used to identify the application, on the interchange recipient's system, to which the interchange is directed. This data element may only be used if the interchange contains only one type of message, (e.g. only invoices). The reference used in this data element is assigned by the interchange sender.

DE 0031: This data element is used to indicate whether an acknowledgement to the interchange is required. The EANCOM® APERAK or CONTRL message should be used to provide acknowledgement of interchange receipt. In addition, the EANCOM® CONTRL message may be used to indicate when an interchange has been rejected due to syntax errors.

DE 0032: This data element is used to identify any underlying agreements which control the exchange of data. Within EANCOM®, the identity of such agreements must start with the letters 'EANCOM', the remaining characters within the data element being filled according to bilateral

Max. Occ. = Maximum Occurrence, St = Status, \* = Restricted Codes

Status: M=Mandatory, R=Required, O=Optional, C=Conditional, D=Dependent, A=Advised, N=Not used

## Segment Layout

---

agreements.

Example: UNB+UNOA:3+4012345000009:14:1+4000004000002:14:4000004000099+021013:1043+12345555+  
REF:AA++A+1+EANCOM-DISI+1'

Example: UNB+UNOA:3+5412345678908:14+8798765432106:14+020102:1000+12345555+++++EANCOMREF  
52'

Max. Occ. = Maximum Occurrence, St = Status, \* = Restricted Codes

Status: M=Mandatory, R=Required, O=Optional, C=Conditional, D=Dependent, A=Advised, N=Not used

## Segment Layout

No. Seg	St	Max. Occ.				
3	<b>UNH</b>	M 1	Message header To head, identify and specify a message.			
Business Term	DE	EDIFACT	Format	St	*	Description
	0062	Message reference number	an..14	M		Senders unique message reference. Sequence number of messages in the interchange. DE 0062 in UNT will have the same value. Generated by the sender.
	S009	Message identifier		M		
	0065	Message type	an..6	M	*	DIRDEB Direct debit message
	0052	Message version number	an..3	M	*	D Draft version/ UN/EDIFACT Directory
	0054	Message release number	an..3	M	*	01B Release 2001 - B
	0051	Controlling agency	an..2	M	*	UN UN/CEFACT
	0057	Association assigned code	an..6	R	*	EAN003 GS1 version control number (GS1 Permanent Code)
<p>This segment is used to head, identify and specify a message.  DE's 0065, 0052, 0054 and 0051: Indicate that the message is a UNSM Direct Debit message based on the D.01B directory.  Example:  Example: UNH+X+DIRDEB:D:01B:UN:EAN003'  Example: UNH+00025+DIRDEB:D:01B:UN:EAN003'</p>						

Max. Occ. = Maximum Occurrence, St = Status, \* = Restricted Codes

Status: M=Mandatory, R=Required, O=Optional, C=Conditional, D=Dependent, A=Advised, N=Not used

## Segment Layout

No. Seg	St	Max. Occ.				
4	<b>BGM</b>	M 1	Beginning of message To indicate the type and function of a message and to transmit the identifying number.			
Business Term	DE	EDIFACT	Format	St	*	Description
	C002	Document/message name		R		
	1001	Document name code	an..3	R	*	214 Pre-authorized direct debit(s) 238 Non-pre-authorized direct debit(s) 243 Pre-authorized direct debit request(s) 244 Non-pre-authorized direct debit request(s) 447 Collection order
	C106	Document/message identification		R		
	1004	Document identifier	an..35	R		Direct debit number assigned by document sender.
	1225	Message function code	an..3	R	*	7 Duplicate 9 Original
	4343	Response type code	an..3	D		AB Message acknowledgement NA No acknowledgement needed AS Credit advice and message acknowledgement YW7 Credit advice (SWIFT Code)
<p>This segment is used to indicate the type and function of the message and to transmit the identifying number. Example:</p> <p>Example: BGM+214+X+7+AA ' Example: BGM+214+3452+9+AB '</p>						

Max. Occ. = Maximum Occurrence, St = Status, \* = Restricted Codes

Status: M=Mandatory, R=Required, O=Optional, C=Conditional, D=Dependent, A=Advised, N=Not used



**Segment Layout**

No.	Seg	St	Max. Occ.			
5	<b>DTM</b>	M	1	Date/time/period To specify date, and/or time, or period.		
Business Term	DE	EDIFACT	Format	St	*	Description
	C507	Date/time/period		M		
	2005	Date or time or period function code qualifier	an..3	M	*	137 Document/ message date/ time
	2380	Date or time or period value	an..35	R		
	2379	Date or time or period format code	an..3	R		102 CCYYMMDD 203 CCYYMMDDHHMM
<p>This segment is used to specify the date on which the Direct Debit message was created.  DE 2005: Identification of the 'Document/message date/time' (code value 137) is mandatory in an EANCOM message.  Example:  Example: DTM+137:19970630:102'  Example: DTM+137:20000124:102'</p>						

Max. Occ. = Maximum Occurrence, St = Status, \* = Restricted Codes

Status: M=Mandatory, R=Required, O=Optional, C=Conditional, D=Dependent, A=Advised, N=Not used

**Segment Layout**

No. Seg	St	Max. Occ.				
6	<b>BUS</b>	C 1	Business function			
To provide information related to the processing and purpose of a financial message.						
Business Term	DE	EDIFACT	Format	St	*	Description
	C521	Business function		N		
	4027	Business function type code qualifier	an..3			
	3279	Geographic area code	an..3	R		DO Domestic DR Domestic with regulatory information required IN International IR International with regulatory information required YC4 European (SWIFT Code)
<p>This segment is used to indicate the geographical environment of the direct debits contained in the message. Example: Example: BUS++DO' Example: BUS++DO'</p>						

Max. Occ. = Maximum Occurrence, St = Status, \* = Restricted Codes

Status: M=Mandatory, R=Required, O=Optional, C=Conditional, D=Dependent, A=Advised, N=Not used

**Segment Layout**

No. Seg	St	Max. Occ.				
<b>SG2</b>	C	5	FII			
A group of segments identifying the financial institutions involved in the direct debit.						
7			<b>FII</b>			
	M	1	Financial institution information			
To identify an account and a related financial institution.						
Business Term	DE	EDIFACT	Format	St	*	Description
	3035	Party function code qualifier	an..3	M		AS Account servicing financial institution HP Final message recipient MR Message recipient
	C078	Account holder identification		N		
	3194	Account holder identifier	an..35			
	C088	Institution identification		R		
	3433	Institution name code	an..11	A		
	1131	Code list identification code	an..17	O		25 Bank identification
	3055	Code list responsible agency code	an..3	D		5 ISO (International Organization for Standardization)
	3434	Institution branch identifier	an..17	O		
	1131	Code list identification code	an..17	O		
	3055	Code list responsible agency code	an..3	D		5 ISO (International Organization for Standardization)
	3432	Institution name	an..70	O		
	3436	Institution branch location name	an..70	O		
	3207	Country name code	an..3	D		
<p>This segment is used to identify the receiving financial institution of the Direct Debit message. The preferred way to identify a bank and its branch is in machine readable format using data elements 3433 and 3434. When using C088 it is recommended that if data element 3433 is not used that 3432 be used, and that when data element 3434 is not used that data element 3436 be used.</p> <p>Example: The bank receiving the direct debit message is identified using the bank identification code KREDBEBB (which is maintained by ISO).</p> <p>Example: FII+MS++BK:25:5:X:23:2:X:X+AD' Example: FII+MR++KREDBEBB:25:5'</p>						

Max. Occ. = Maximum Occurrence, St = Status, \* = Restricted Codes

Status: M=Mandatory, R=Required, O=Optional, C=Conditional, D=Dependent, A=Advised, N=Not used

**Segment Layout**

No. Seg	St	Max. Occ.				
<b>SG3</b>	C	3	NAD			
A group of segments identifying the name(s) and address(es) of each non-financial party involved in the transaction.						
8	<b>NAD</b>	M	1	Name and address		
To specify the name/address and their related function, either by C082 only and/or unstructured by C058 or structured by C080 thru 3207.						
Business Term	DE	EDIFACT	Format	St	*	Description
	3035	Party function code qualifier	an..3	M		HQ Owner of account (SWIFT Code) MS Document/message issuer/sender
	C082	Party identification details		A		
	3039	Party identifier	an..35	M		
	1131	Code list identification code	an..17	O		
	3055	Code list responsible agency code	an..3	D		9 GS1
	C058	Name and address		O		This composite may only be used to fulfill the requirements of directive 2003/58/EC, article 4.
	3124	Name and address description	an..35	M		
	3124	Name and address description	an..35	O		
	3124	Name and address description	an..35	O		
	3124	Name and address description	an..35	O		
	3124	Name and address description	an..35	O		
	C080	Party name		D		
	3036	Party name	an..35	M		Party name in clear text.
	3036	Party name	an..35	O		
	3036	Party name	an..35	O		
	3036	Party name	an..35	O		
	3036	Party name	an..35	O		
	3045	Party name format code	an..3	O		
	C059	Street		D		
	3042	Street and number or post office box identifier	an..35	M		Building Name/Number and Street Name
	3042	Street and number or post office box identifier	an..35	O		
		Street and number or				

Max. Occ. = Maximum Occurrence, St = Status, \* = Restricted Codes

Status: M=Mandatory, R=Required, O=Optional, C=Conditional, D=Dependent, A=Advised, N=Not used

**Segment Layout**

Business Term	DE	EDIFACT	Format	St	*	Description
	3042	post office box identifier	an..35	O		
	3042	Street and number or post office box identifier	an..35	O		
	3164	City name	an..35	D		City/Town name, clear text
	C819	Country sub-entity details		D		
	3229	Country sub-entity name code	an..9	O		
	1131	Code list identification code	an..17	O		
	3055	Code list responsible agency code	an..3	O		
	3228	Country sub-entity name	an..70	O		County/State, clear text.
	3251	Postal identification code	an..17	D		Postal code
	3207	Country name code	an..3	D		ISO 3166 two alpha country code

This segment is used to identify the sender of the direct debit message.

Example:

Dependency Notes:

The following composites and data elements are only used when a coded name and address can not be used. The affected composites and data elements are as follows;

C080 - C059 - 3164 - C819 - 3251 - 3207

Example: NAD+P1+123456789:23:2+X:::X+X:X:X:X:X:1+X:X:X+X+X:23:2:X+X+AD'

Example: NAD+MS+5422331123459::9'

Max. Occ. = Maximum Occurrence, St = Status, \* = Restricted Codes

Status: M=Mandatory, R=Required, O=Optional, C=Conditional, D=Dependent, A=Advised, N=Not used

## Segment Layout

No. Seg	St	Max. Occ.				
<b>SG4</b>	M	9999	LIN-DTM-RFF-BUS-FCA-SG5-SG6-SG7-SG8-SG9-SG10-SG11			
A group of segments containing information regarding the credit side of the transaction and details which are pertinent to all direct debits specified within the group. Certain payment details may be provided either in segment group 4 or in segment group 11, but not in both.						
9			<b>LIN</b>	M	1	Line item
To identify a line item and configuration.						
Business Term	DE	EDIFACT	Format	St	*	Description
	1082	Line item identifier	an..6	R		
<p>This segment is used to identify a line within the direct debit by means of a incrementing unique line number.</p> <p>Note on DE 1082:                      Numbering rule: In Part I, section 4.10 there is the recommendation "Within EANCOM® it is recommended that the line numbers used in the first occurrence of data element 1082 in the LIN segment be sequential, starting at 1 for each new message."</p> <p>Example: LIN+1 '                      Example: LIN+1 '</p>						

Max. Occ. = Maximum Occurrence, St = Status, \* = Restricted Codes  
 Status: M=Mandatory, R=Required, O=Optional, C=Conditional, D=Dependent, A=Advised, N=Not used

## Segment Layout

No. Seg	St	Max. Occ.				
<b>SG4</b>	M	9999	LIN-DTM-RFF-BUS-FCA-SG5-SG6-SG7-SG8-SG9-SG10-SG11			
A group of segments containing information regarding the credit side of the transaction and details which are pertinent to all direct debits specified within the group. Certain payment details may be provided either in segment group 4 or in segment group 11, but not in both.						
10	<b>DTM</b>	C 1	Date/time/period			
To specify date, and/or time, or period.						
Business Term	DE	EDIFACT	Format	St	*	Description
	C507	Date/time/period		M		
	2005	Date or time or period function code qualifier	an..3	M	*	203 Execution date/ time, requested 447 Creditor's requested value date
	2380	Date or time or period value	an..35	R		
	2379	Date or time or period format code	an..3	R		102 CCYYMMDD
This segment is used to specify a date related to the batch (credit side) of direct debits. This date applies to all individual transactions which do not have an individual date specified. Example: Example: DTM+203:19980830:102' Example: DTM+203:20000626:102'						

Max. Occ. = Maximum Occurrence, St = Status, \* = Restricted Codes

Status: M=Mandatory, R=Required, O=Optional, C=Conditional, D=Dependent, A=Advised, N=Not used

## Segment Layout

No. Seg	St	Max. Occ.				
<b>SG4</b>	M	9999	LIN-DTM-RFF-BUS-FCA-SG5-SG6-SG7-SG8-SG9-SG10-SG11			
			A group of segments containing information regarding the credit side of the transaction and details which are pertinent to all direct debits specified within the group. Certain payment details may be provided either in segment group 4 or in segment group 11, but not in both.			
11	<b>RFF</b>	C 2	Reference			
			To specify a reference.			
Business Term	DE	EDIFACT	Format	St	*	Description
	C506	Reference		M		
	1153	Reference code qualifier	an..3	M		AEK Payment order number AHL Creditor's reference number
	1154	Reference identifier	an..70	R		
<p>This segment is used to identify the reference number of the credit transaction which results from the message. This number, along with the message number detailed in data element 1004 in the BGM segment, are passed back to the debtor in the debit advice (and multiple debit advice), banking status, and financial messages.</p> <p>Example:</p> <p>Example: RFF+AEK:12345'</p> <p>Example: RFF+AHL:3250527841'</p>						

Max. Occ. = Maximum Occurrence, St = Status, \* = Restricted Codes

Status: M=Mandatory, R=Required, O=Optional, C=Conditional, D=Dependent, A=Advised, N=Not used



## Segment Layout

No. Seg	St	Max. Occ.				
<b>SG4</b>	M	9999	LIN-DTM-RFF-BUS-FCA-SG5-SG6-SG7-SG8-SG9-SG10-SG11			
A group of segments containing information regarding the credit side of the transaction and details which are pertinent to all direct debits specified within the group. Certain payment details may be provided either in segment group 4 or in segment group 11, but not in both.						
12	<b>BUS</b>	C 1	Business function			
To provide information related to the processing and purpose of a financial message.						
Business Term	DE	EDIFACT	Format	St	*	Description
	C521	Business function		D		
	4027	Business function type code qualifier	an..3	M	*	1 Underlying business function
	4025	Business function code	an..3	M		AAN Business expenses COM Commission COS Costs GDS Purchase and sale of goods INS Insurance premium INT Interest LOR Loan repayment NET Netting PEN Pension REN Rent SCV Purchase and sale of services SUB Subscription TAX Tax payment
	1131	Code list identification code	an..17	O		
	3055	Code list responsible agency code	an..3	D		17 S.W.I.F.T.
	4022	Business description	an..70	O		
	3279	Geographic area code	an..3	R	*	DO Domestic IN International YC4 European (SWIFT Code)
	4487	Financial transaction type code	an..3	O		1 Clean payment
	C551	Bank operation		N		
	4383	Bank operation code	an..3			
	4463	Intra-company payment indicator code	an..3	O		1 Intra-company payment
<p>This segment is used to identify the characteristics of the transactions detailed in level C of the message.</p> <p>When this segment is not used the message defaults to a non-intra company domestic clean payment.</p> <p>Example: The batch of direct debits relate to a clean international payment for the purchase/sale of goods.</p>						

Max. Occ. = Maximum Occurrence, St = Status, \* = Restricted Codes

Status: M=Mandatory, R=Required, O=Optional, C=Conditional, D=Dependent, A=Advised, N=Not used

## Segment Layout

---

Example: BUS+1:ADV:23:2:X+D0+1++1'

Example: BUS+1:GDS+IN'

## Segment Layout

No. Seg	St	Max. Occ.				
<b>SG4</b>	M	9999	LIN-DTM-RFF-BUS-FCA-SG5-SG6-SG7-SG8-SG9-SG10-SG11			
A group of segments containing information regarding the credit side of the transaction and details which are pertinent to all direct debits specified within the group. Certain payment details may be provided either in segment group 4 or in segment group 11, but not in both.						
13	<b>FCA</b>	C 1	Financial charges allocation			
Description of allocation of charges.						
Business Term	DE	EDIFACT	Format	St	*	Description
	4471	Settlement means code	an..3	M	*	13 All charges borne by payee 14 Each pay own cost 15 All charges borne by payor
	C878	Charge/allowance account		D		Composite data element C878 should only be provided if the account number against which charges are to be allocated are different to the debtor's account (debit account) number.
	3434	Institution branch identifier	an..17	M		
	1131	Code list identification code	an..17	O		25 Bank identification 154 Bank branch sorting identification
	3055	Code list responsible agency code	an..3	D		5 ISO (International Organization for Standardization)
	3194	Account holder identifier	an..35	O		
	6345	Currency identification code	an..3	O		ISO 4217 currency code
<p>This segment is used to identify the party on which any charges are allocated and the account to which the charges should be directed.</p> <p>Example:</p> <p>Example: FCA+13+X:23:2:X:EUR '</p> <p>Example: FCA+15 '</p>						

Max. Occ. = Maximum Occurrence, St = Status, \* = Restricted Codes

Status: M=Mandatory, R=Required, O=Optional, C=Conditional, D=Dependent, A=Advised, N=Not used

## Segment Layout

No. Seg	St	Max. Occ.				
<b>SG4</b>	M	9999	LIN-DTM-RFF-BUS-FCA-SG5-SG6-SG7-SG8-SG9-SG10-SG11			
A group of segments containing information regarding the credit side of the transaction and details which are pertinent to all direct debits specified within the group. Certain payment details may be provided either in segment group 4 or in segment group 11, but not in both.						
<b>SG5</b>	C	1	MOA-CUX-DTM-RFF			
A group of segments containing the currency of the single amounts on the debit side of the transaction (C level), currency to be collected, plus the total of all single amounts of the debit side of the transaction (C level).						
14	<b>MOA</b>	M	1	Monetary amount		
To specify a monetary amount.						
Business Term	DE	EDIFACT	Format	St	*	Description
	C516	Monetary amount		M		
	5025	Monetary amount type code qualifier	an..3	M	*	<p>9 Amount due/ amount payable</p> <p>57 Equivalent amount</p> <p>When code 57 (equivalent amount) is used in this data element it is used to instruct a bank to credit an account of the beneficiary by a specified amount of the account currency and to debit the ordering customers account by an equivalent amount in a currency specified in the CUX segment.</p>
	5004	Monetary amount	n..35	R		
	6345	Currency identification code	an..3	D		ISO 4217 currency code
<p>This segment is used to specify the total amount for this batch of direct debits, the currency in which it is stated, and an indication whether this amount is the total of the transaction amounts or of bank settlement amounts.</p> <p>Example:</p> <p>Example: MOA+9:122.34:USD'</p> <p>Example: MOA+9:430000:EUR'</p>						

Max. Occ. = Maximum Occurrence, St = Status, \* = Restricted Codes

Status: M=Mandatory, R=Required, O=Optional, C=Conditional, D=Dependent, A=Advised, N=Not used

## Segment Layout

No. Seg	St	Max. Occ.				
<b>SG4</b>	M	9999	LIN-DTM-RFF-BUS-FCA-SG5-SG6-SG7-SG8-SG9-SG10-SG11			
A group of segments containing information regarding the credit side of the transaction and details which are pertinent to all direct debits specified within the group. Certain payment details may be provided either in segment group 4 or in segment group 11, but not in both.						
<b>SG5</b>	C	1	MOA-CUX-DTM-RFF			
A group of segments containing the currency of the single amounts on the debit side of the transaction (C level), currency to be collected, plus the total of all single amounts of the debit side of the transaction (C level).						
15	<b>CUX</b>	C	1	Currencies		
To specify currencies used in the transaction and relevant details for the rate of exchange.						
Business Term	DE	EDIFACT	Format	St	*	Description
	C504	Currency details		R		
	6347	Currency usage code qualifier	an..3	M	*	2 Reference currency
	6345	Currency identification code	an..3	R		ISO 4217 currency code
	6343	Currency type code qualifier	an..3	N		
	6348	Currency rate value	n..4	D		This data element is only used when a rate of exchange is provided in data element 5402. When a rate of exchange is provided then at least one currency rate base must be specified.
	C504	Currency details		D		The second occurrence of this composite is only used if a target currency is being specified.
	6347	Currency usage code qualifier	an..3	M	*	3 Target currency
	6345	Currency identification code	an..3	R		ISO 4217 currency code
	6343	Currency type code qualifier	an..3	N		
	6348	Currency rate value	n..4	D		This data element is only used when a rate of exchange is provided in data element 5402. When a rate of exchange is provided then at least one currency rate base must be specified.
	5402	Currency exchange rate	n..12	D		The rate of exchange is only used if a target currency has been identified in the second occurrence of C504.
	6341	Exchange rate	an..3	O		

Max. Occ. = Maximum Occurrence, St = Status, \* = Restricted Codes

Status: M=Mandatory, R=Required, O=Optional, C=Conditional, D=Dependent, A=Advised, N=Not used

## Segment Layout

Business Term	DE	EDIFACT	Format	St	*	Description
		currency market identifier				
<p>This segment is used to specify the currency of the monetary amount detailed in the previous MOA segment. The CUX segment is only used if code 57 (Equivalent amount) has been used in data element 5025 of the previous MOA segment.</p> <p>When specifying the Reference and Target currencies for international trade, one occurrence of CUX is all that is required. The reference currency is identified in the first occurrence of composite C504, with the target currency specified in the second occurrence of C504. The rate of exchange between the two is detailed in DE 5402.</p> <p>The general rule for calculating the rate of exchange is as follows;            Reference Currency multiplied by Rate = Target Currency.            Example:</p> <p>Example: CUX+2:EUR::9+3:EUR::9+9+AMS '            Example: CUX+2:EUR+3:USD+0.90243 '</p>						

Max. Occ. = Maximum Occurrence, St = Status, \* = Restricted Codes

Status: M=Mandatory, R=Required, O=Optional, C=Conditional, D=Dependent, A=Advised, N=Not used

## Segment Layout

No. Seg	St	Max. Occ.				
<b>SG4</b>	M	9999	LIN-DTM-RFF-BUS-FCA-SG5-SG6-SG7-SG8-SG9-SG10-SG11			
A group of segments containing information regarding the credit side of the transaction and details which are pertinent to all direct debits specified within the group. Certain payment details may be provided either in segment group 4 or in segment group 11, but not in both.						
<b>SG5</b>	C	1	MOA-CUX-DTM-RFF			
A group of segments containing the currency of the single amounts on the debit side of the transaction (C level), currency to be collected, plus the total of all single amounts of the debit side of the transaction (C level).						
16	<b>DTM</b>	C	2	Date/time/period		
To specify date, and/or time, or period.						
Business Term	DE	EDIFACT	Format	St	*	Description
	C507	Date/time/period		M		
	2005	Date or time or period function code qualifier	an..3	M	*	134 Rate of exchange date/time 171 Reference date/time
	2380	Date or time or period value	an..35	R		
	2379	Date or time or period format code	an..3	R		102 CCYYMMDD 203 CCYYMMDDHHMM
This segment is used to specify reference and rate of exchange dates. Example: Example: DTM+134:X:2' Example: DTM+134:20000121:102'						

Max. Occ. = Maximum Occurrence, St = Status, \* = Restricted Codes

Status: M=Mandatory, R=Required, O=Optional, C=Conditional, D=Dependent, A=Advised, N=Not used

## Segment Layout

No. Seg	St	Max. Occ.				
<b>SG4</b>	M	9999	LIN-DTM-RFF-BUS-FCA-SG5-SG6-SG7-SG8-SG9-SG10-SG11			
A group of segments containing information regarding the credit side of the transaction and details which are pertinent to all direct debits specified within the group. Certain payment details may be provided either in segment group 4 or in segment group 11, but not in both.						
<b>SG5</b>	C	1	MOA-CUX-DTM-RFF			
A group of segments containing the currency of the single amounts on the debit side of the transaction (C level), currency to be collected, plus the total of all single amounts of the debit side of the transaction (C level).						
17	<b>RFF</b>	C	1	Reference		
To specify a reference.						
Business Term	DE	EDIFACT	Format	St	*	Description
	C506	Reference		M		
	1153	Reference code qualifier	an..3	M	*	ACX Banker's acceptance ADB Matured certificate of deposit ADC Loan FX Foreign exchange contract number
	1154	Reference identifier	an..70	R		
This segment is used to provide references to other transactions negotiated between the creditor and the creditors bank which will be used to finance the direct debit, e.g. a separate foreign exchange deal. Example: Example: RFF+ACX:X' Example: RFF+FX:926744'						

Max. Occ. = Maximum Occurrence, St = Status, \* = Restricted Codes

Status: M=Mandatory, R=Required, O=Optional, C=Conditional, D=Dependent, A=Advised, N=Not used



## Segment Layout

No. Seg	St	Max. Occ.				
<b>SG4</b>	M	9999	LIN-DTM-RFF-BUS-FCA-SG5-SG6-SG7-SG8-SG9-SG10-SG11			
A group of segments containing information regarding the credit side of the transaction and details which are pertinent to all direct debits specified within the group. Certain payment details may be provided either in segment group 4 or in segment group 11, but not in both.						
<b>SG6</b>	M	1	FII			
A group of segments containing the account servicing bank including the account to be credited. If the creditor is not quoted separately in the NAD segment on the credit side of the transaction (B level), then this group also contains the information of the creditor.						
18	<b>FII</b>	M	1	Financial institution information		
To identify an account and a related financial institution.						
Business Term	DE	EDIFACT	Format	St	*	Description
	3035	Party function code qualifier	an..3	M		CRB Creditor's bank (SWIFT Code)
	C078	Account holder identification		R		
	3194	Account holder identifier	an..35	R		
	3192	Account holder name	an..35	O		
	3192	Account holder name	an..35	O		
	6345	Currency identification code	an..3	O		ISO 4217 currency code
	C088	Institution identification		D		In some countries it is possible to identify within the account number the institution name and branch. Where this is possible the composite C088 will not be required. For international transactions it is recommended that the need for composite C088 should be checked before sending the message.
	3433	Institution name code	an..11	A		
	1131	Code list identification code	an..17	O		25 Bank identification
	3055	Code list responsible agency code	an..3	D		5 ISO (International Organization for Standardization)
	3434	Institution branch identifier	an..17	O		
	1131	Code list identification code	an..17	O		
	3055	Code list responsible agency code	an..3	D		5 ISO (International Organization for Standardization)
	3432	Institution name	an..70	O		

Max. Occ. = Maximum Occurrence, St = Status, \* = Restricted Codes

Status: M=Mandatory, R=Required, O=Optional, C=Conditional, D=Dependent, A=Advised, N=Not used

**Segment Layout**

Business Term	DE	EDIFACT	Format	St	*	Description
	3436	Institution branch location name	an..70	O		
	3207	Country name code	an..3	O		ISO 3166 country code

This segment is used to identify the financial institution and account information related to the creditor.

The preferred way to identify a bank and its branch is in machine readable format using data elements 3433 and 3434. When using C088 it is recommended that if data element 3433 is not used that 3432 be used, and that when data element 3434 is not used that data element 3436 be used.

Example:

The ordering customer is identified as being N Geiss with a bank account number of 994-3277711.

Example: FII+CRB+12345:N GEISS:X:USD+BK:25:2:50040000:25:2:X:X+AD'

Example: FII+CRB+994-3277711:N GEISS'

Max. Occ. = Maximum Occurrence, St = Status, \* = Restricted Codes

Status: M=Mandatory, R=Required, O=Optional, C=Conditional, D=Dependent, A=Advised, N=Not used

**Segment Layout**

No. Seg	St	Max. Occ.				
<b>SG4</b>	M	9999	LIN-DTM-RFF-BUS-FCA-SG5-SG6-SG7-SG8-SG9-SG10-SG11			
A group of segments containing information regarding the credit side of the transaction and details which are pertinent to all direct debits specified within the group. Certain payment details may be provided either in segment group 4 or in segment group 11, but not in both.						
<b>SG7</b>	C	3	NAD			
A group of segments identifying the creditor. Furthermore, one contact party can also be quoted in this group.						
19	<b>NAD</b>	M	1	Name and address		
To specify the name/address and their related function, either by C082 only and/or unstructured by C058 or structured by C080 thru 3207.						
Business Term	DE	EDIFACT	Format	St	*	Description
	3035	Party function code qualifier	an..3	M		CRE Creditor (SWIFT Code)
	C082	Party identification details		A		
	3039	Party identifier	an..35	M		
	1131	Code list identification code	an..17	O		
	3055	Code list responsible agency code	an..3	D		9 GS1
	C058	Name and address		O		This composite may only be used to fulfill the requirements of directive 2003/58/EC, article 4.
	3124	Name and address description	an..35	M		
	3124	Name and address description	an..35	O		
	3124	Name and address description	an..35	O		
	3124	Name and address description	an..35	O		
	3124	Name and address description	an..35	O		
	C080	Party name		D		
	3036	Party name	an..35	M		Party name in clear text.
	3036	Party name	an..35	O		
	3036	Party name	an..35	O		
	3036	Party name	an..35	O		
	3036	Party name	an..35	O		
	3045	Party name format code	an..3	O		
	C059	Street		D		
	3042	Street and number or post office box	an..35	M		Building Name/Number and Street Name

Max. Occ. = Maximum Occurrence, St = Status, \* = Restricted Codes

Status: M=Mandatory, R=Required, O=Optional, C=Conditional, D=Dependent, A=Advised, N=Not used

**Segment Layout**

Business Term	DE	EDIFACT	Format	St	*	Description
		identifier				
	3042	Street and number or post office box identifier	an..35	O		
	3042	Street and number or post office box identifier	an..35	O		
	3042	Street and number or post office box identifier	an..35	O		
	3164	City name	an..35	D		City/Town name, clear text
	C819	Country sub-entity details		D		
	3229	Country sub-entity name code	an..9	O		
	1131	Code list identification code	an..17	O		
	3055	Code list responsible agency code	an..3	O		
	3228	Country sub-entity name	an..70	O		County/State, clear text.
	3251	Postal identification code	an..17	D		Postal code
	3207	Country name code	an..3	D		ISO 3166 two alpha code

This segment is used to identify the creditor that will receive the credit transaction.

Example:

Dependency Notes:

The following composites and data elements are only used when a coded name and address can not be used. The affected composites and data elements are as follows;

C080 - C059 - 3164 - C819 - 3251 - 3207

Example: NAD+CRE+123456789:23:2+X:::X+X:X:X:X:X:1+X:X:X:X+X+X:23:2:X+X+AD'

Example: NAD+CRE+5422331123459:::9'

Max. Occ. = Maximum Occurrence, St = Status, \* = Restricted Codes

Status: M=Mandatory, R=Required, O=Optional, C=Conditional, D=Dependent, A=Advised, N=Not used

## Segment Layout

No. Seg	St	Max. Occ.				
<b>SG4</b>	M	9999	LIN-DTM-RFF-BUS-FCA-SG5-SG6-SG7-SG8-SG9-SG10-SG11			
A group of segments containing information regarding the credit side of the transaction and details which are pertinent to all direct debits specified within the group. Certain payment details may be provided either in segment group 4 or in segment group 11, but not in both.						
<b>SG8</b>	C	1	INP-FTX-DTM			
A group of segments containing instructions from the creditor relating to parties identified in the NAD and FII segments. It specifies action to be taken by the identified parties, and the date (and optionally time) by which such action needs to be taken.						
20	<b>INP</b>	M	1	Parties and instruction		
To specify parties to an instruction, the instruction, or both.						
Business Term	DE	EDIFACT	Format	St	*	Description
	C849	Parties to instruction		D		
	3301	Enacting party identifier	an..35	M		CRB Creditor's bank (SWIFT Code)
	3285	Instruction receiving party identifier	an..35	D		CRB Creditor's bank (SWIFT Code) CRE Creditor (SWIFT Code)
	C522	Instruction		O		
	4403	Instruction type code qualifier	an..3	M		2 Party instructions
	4401	Instruction description code	an..3	O		
	1131	Code list identification code	an..17	O		
	3055	Code list responsible agency code	an..3	D		
	4400	Instruction description	an..35	O		
<p>This segment is used to identify the party who must carry out an instruction from the creditor, and the party to whom the instruction is intended.</p> <p>DE's 3301 and 3285: As these data elements are being used to provide coded information it is recommended that their format and length be restricted to an..3.</p> <p>Example:</p> <p>Example: INP+CRB:CRB+2:AD:23:2:X'</p> <p>Example: INP+CRB:CRE+2:EM'</p>						

Max. Occ. = Maximum Occurrence, St = Status, \* = Restricted Codes

Status: M=Mandatory, R=Required, O=Optional, C=Conditional, D=Dependent, A=Advised, N=Not used

## Segment Layout

No. Seg	St	Max. Occ.				
<b>SG4</b>	M	9999	LIN-DTM-RFF-BUS-FCA-SG5-SG6-SG7-SG8-SG9-SG10-SG11			
A group of segments containing information regarding the credit side of the transaction and details which are pertinent to all direct debits specified within the group. Certain payment details may be provided either in segment group 4 or in segment group 11, but not in both.						
<b>SG8</b>	C	1	INP-FTX-DTM			
A group of segments containing instructions from the creditor relating to parties identified in the NAD and FII segments. It specifies action to be taken by the identified parties, and the date (and optionally time) by which such action needs to be taken.						
21	<b>FTX</b>	C	1	Free text		
To provide free form or coded text information.						
Business Term	DE	EDIFACT	Format	St	*	Description
	4451	Text subject code qualifier	an..3	M		AAG Party instructions
	4453	Free text function code	an..3	N		
	C107	Text reference		D		This composite is only used when trading partners have agreed to use mutually defined code values.
	4441	Free text value code	an..17	M		
	1131	Code list identification code	an..17	O		
	3055	Code list responsible agency code	an..3	D		86 Assigned by party originating the message
	C108	Text literal		D		This composite is only used if coded text can not be used.
	4440	Free text value	an..51	M		
	4440	Free text value	an..51	O		
	4440	Free text value	an..51	O		
	4440	Free text value	an..51	O		
	4440	Free text value	an..51	O		
	3453	Language name code	an..3	D		This data element is only used when non coded free text has been provided in data element C108.
<p>This segment is used to provide additional coded or free text instructions to those provided in the INP segment.</p> <p>Use of this segment in free form is not recommended since in most cases it inhibits automatic processing of the direct debit message. Coded references to standard texts is an available functionality which enables automatic processing and reduces transmission and processing overheads. Standard texts should be mutually defined among trading partners and can be used to cover legal and other requirements.</p> <p>Example:</p>						

Max. Occ. = Maximum Occurrence, St = Status, \* = Restricted Codes

Status: M=Mandatory, R=Required, O=Optional, C=Conditional, D=Dependent, A=Advised, N=Not used

## Segment Layout

---

Example: FTX+AAG++1E:23:2+BEWARE EMBARGO PAYMENTS:X:X:X:X+EN'

Example: FTX+AAG+++BEWARE EMBARGO PAYMENTS+EN'

Max. Occ. = Maximum Occurrence, St = Status, \* = Restricted Codes

Status: M=Mandatory, R=Required, O=Optional, C=Conditional, D=Dependent, A=Advised, N=Not used

**Segment Layout**

No. Seg	St	Max. Occ.				
<b>SG4</b>	M	9999	LIN-DTM-RFF-BUS-FCA-SG5-SG6-SG7-SG8-SG9-SG10-SG11			
A group of segments containing information regarding the credit side of the transaction and details which are pertinent to all direct debits specified within the group. Certain payment details may be provided either in segment group 4 or in segment group 11, but not in both.						
<b>SG8</b>	C	1	INP-FTX-DTM			
A group of segments containing instructions from the creditor relating to parties identified in the NAD and FII segments. It specifies action to be taken by the identified parties, and the date (and optionally time) by which such action needs to be taken.						
22	<b>DTM</b>	C	2	Date/time/period		
To specify date, and/or time, or period.						
Business Term	DE	EDIFACT	Format	St	*	Description
	C507	Date/time/period		M		
	2005	Date or time or period function code qualifier	an..3	M		9 Processing date/time 174 Advise after date/time 175 Advise before date/time 176 Advise completed date/time 177 Advise on date/time
	2380	Date or time or period value	an..35	R		
	2379	Date or time or period format code	an..3	R		102 CCYYMMDD 203 CCYYMMDDHHMM 713 YYMMDDHHMM-YYMMDDHHMM
This segment is used to specify the dates and or times related to the instructions. Example: Advise before 10am on the 17th of June 2002.  Example: DTM+2:X:102' Example: DTM+175:200206171000:203'						

Max. Occ. = Maximum Occurrence, St = Status, \* = Restricted Codes  
Status: M=Mandatory, R=Required, O=Optional, C=Conditional, D=Dependent, A=Advised, N=Not used



## Segment Layout

No. Seg	St	Max. Occ.				
<b>SG4</b>	M	9999	LIN-DTM-RFF-BUS-FCA-SG5-SG6-SG7-SG8-SG9-SG10-SG11			
<p>A group of segments containing information regarding the credit side of the transaction and details which are pertinent to all direct debits specified within the group. Certain payment details may be provided either in segment group 4 or in segment group 11, but not in both.</p>						
<b>SG9</b>	C	10	GIS-MOA-LOC-NAD-RCS-FTX			
<p>A group of segments providing information for subsequent use by regulatory authorities requiring statistical and other types of data. It also identifies the regulatory authority for which the information is intended followed by the information itself.</p>						
23	<b>GIS</b>	M	1	General indicator		
<p>To transmit a processing indicator.</p>						
<p>Notes: 1. This segment will be removed effective with directory D.02B.</p>						
Business Term	DE	EDIFACT	Format	St	*	Description
	C529	Processing indicator		M		
	7365	Processing indicator description code	an..3	M	*	10 Declaration requested 37 Complete information
	1131	Code list identification code	an..17	O		
	3055	Code list responsible agency code	an..3	O		
	7187	Process type description code	an..17	O		
<p>This segment is used to indicate that the information contained in the following segments will be passed on to and processed by the central and regulatory party identified in the NAD segment. Note: The use of this segment group is subject to national regulations stipulated by regulatory authorities, e.g. Central Bank. Example: Example: GIS+10:23:2:8' Example: GIS+10'</p>						

Max. Occ. = Maximum Occurrence, St = Status, \* = Restricted Codes  
Status: M=Mandatory, R=Required, O=Optional, C=Conditional, D=Dependent, A=Advised, N=Not used

## Segment Layout

No. Seg	St	Max. Occ.				
<b>SG4</b>	M	9999	LIN-DTM-RFF-BUS-FCA-SG5-SG6-SG7-SG8-SG9-SG10-SG11			
A group of segments containing information regarding the credit side of the transaction and details which are pertinent to all direct debits specified within the group. Certain payment details may be provided either in segment group 4 or in segment group 11, but not in both.						
<b>SG9</b>	C	10	GIS-MOA-LOC-NAD-RCS-FTX			
A group of segments providing information for subsequent use by regulatory authorities requiring statistical and other types of data. It also identifies the regulatory authority for which the information is intended followed by the information itself.						
24	<b>MOA</b>	C	1	Monetary amount		
To specify a monetary amount.						
Business Term	DE	EDIFACT	Format	St	*	Description
	C516	Monetary amount		M		
	5025	Monetary amount type code qualifier	an..3	M		139 Total payment amount
	5004	Monetary amount	n..35	O		
	6345	Currency identification code	an..3	O		
	6343	Currency type code qualifier	an..3	O		11 Payment currency
This segment is used to specify monetary amounts which must be reported to the regulatory party identified in the NAD segment. Example: Example: MOA+139:122.34:EUR:11 ' Example: MOA+139:430000:EUR:11 '						

Max. Occ. = Maximum Occurrence, St = Status, \* = Restricted Codes

Status: M=Mandatory, R=Required, O=Optional, C=Conditional, D=Dependent, A=Advised, N=Not used

**Segment Layout**

No. Seg	St	Max. Occ.				
<b>SG4</b>	M	9999	LIN-DTM-RFF-BUS-FCA-SG5-SG6-SG7-SG8-SG9-SG10-SG11			
A group of segments containing information regarding the credit side of the transaction and details which are pertinent to all direct debits specified within the group. Certain payment details may be provided either in segment group 4 or in segment group 11, but not in both.						
<b>SG9</b>	C	10	GIS-MOA-LOC-NAD-RCS-FTX			
A group of segments providing information for subsequent use by regulatory authorities requiring statistical and other types of data. It also identifies the regulatory authority for which the information is intended followed by the information itself.						
25	<b>LOC</b>	C	2	Place/location identification		
To identify a place or a location and/or related locations.						
Business Term	DE	EDIFACT	Format	St	*	Description
	3227	Location function code qualifier	an..3	M		27 Country of origin 28 Country of destination of goods 39 Country of production 40 Country of trading
	C517	Location identification		A		
	3225	Location name code	an..25	A		For country identification see ISO 3166 two alpha code, DE 3207
	1131	Code list identification code	an..17	O		
	3055	Code list responsible agency code	an..3	D		5 ISO (International Organization for Standardization) 9 GS1 DE 3055 must be used if DE 3225 is used and does not contain an UN/LOCODE.
	3224	Location name	an..25	O		
	C519	Related location one identification		N		
	3223	First related location name code	an..25			
	C553	Related location two identification		N		
	3233	Second related location name code	an..25			
	5479	Relation code	an..3	O		
This segment is used to indicate any locations relevant to the regulatory party identified in the NAD segment. Example: Goods were produced in Belgium. Example: LOC+39+BE:23:2:X++X'						

Max. Occ. = Maximum Occurrence, St = Status, \* = Restricted Codes

Status: M=Mandatory, R=Required, O=Optional, C=Conditional, D=Dependent, A=Advised, N=Not used

## Segment Layout

---

Example: LOC+39+BE::5'
------------------------

## Segment Layout

No. Seg	St	Max. Occ.				
<b>SG4</b>	M	9999	LIN-DTM-RFF-BUS-FCA-SG5-SG6-SG7-SG8-SG9-SG10-SG11			
A group of segments containing information regarding the credit side of the transaction and details which are pertinent to all direct debits specified within the group. Certain payment details may be provided either in segment group 4 or in segment group 11, but not in both.						
<b>SG9</b>	C	10	GIS-MOA-LOC-NAD-RCS-FTX			
A group of segments providing information for subsequent use by regulatory authorities requiring statistical and other types of data. It also identifies the regulatory authority for which the information is intended followed by the information itself.						
26	<b>NAD</b>	C	1	Name and address		
To specify the name/address and their related function, either by C082 only and/or unstructured by C058 or structured by C080 thru 3207.						
Business Term	DE	EDIFACT	Format	St	*	Description
	3035	Party function code qualifier	an..3	M	*	RA <b>Central bank or regulatory authority</b>
	C082	Party identification details		A		
	3039	Party identifier	an..35	M		
	1131	Code list identification code	an..17	N		
	3055	Code list responsible agency code	an..3	R	*	9 <b>GS1</b>
	C058	Name and address		O		This composite may only be used to fulfill the requirements of directive 2003/58/EC, article 4.
	3124	Name and address description	an..35	M		
	3124	Name and address description	an..35	O		
	3124	Name and address description	an..35	O		
	3124	Name and address description	an..35	O		
	3124	Name and address description	an..35	O		
	C080	Party name		D		
	3036	Party name	an..35	M		Party name in clear text.
	3036	Party name	an..35	O		
	3036	Party name	an..35	O		
	3036	Party name	an..35	O		
	3036	Party name	an..35	O		
	3045	Party name format code	an..3	O		
	C059	Street		D		

Max. Occ. = Maximum Occurrence, St = Status, \* = Restricted Codes

Status: M=Mandatory, R=Required, O=Optional, C=Conditional, D=Dependent, A=Advised, N=Not used

**Segment Layout**

Business Term	DE	EDIFACT	Format	St	*	Description
	3042	Street and number or post office box identifier	an..35	M		Building Name/Number and Street
	3042	Street and number or post office box identifier	an..35	O		
	3042	Street and number or post office box identifier	an..35	O		
	3042	Street and number or post office box identifier	an..35	O		
	3164	City name	an..35	D		City/town name, clear text.
	C819	Country sub-entity details		D		
	3229	Country sub-entity name code	an..9	O		
	1131	Code list identification code	an..17	O		
	3055	Code list responsible agency code	an..3	O		
	3228	Country sub-entity name	an..70	O		County/State, clear text.
	3251	Postal identification code	an..17	D		Postal code.
	3207	Country name code	an..3	D		ISO 3166 two alpha code

This segment is used to identify the central and regulatory authority specifying the regulatory information detailed in the GIS and FTX segments.

Example:

Dependency Notes:

The following composites and data elements are only used when a coded name and address can not be used. The affected composites and data elements are as follows;

C080 - C059 - 3164 - C819 - 3251 - 3207

Example: NAD+RA+272971234::9+X:::X+X:X:X:X:X:1+X:X:X:X+X+X:23:2:X+X+AD'

Example: NAD+RA+5422331123459::9'

Max. Occ. = Maximum Occurrence, St = Status, \* = Restricted Codes

Status: M=Mandatory, R=Required, O=Optional, C=Conditional, D=Dependent, A=Advised, N=Not used

## Segment Layout

No. Seg	St	Max. Occ.				
<b>SG4</b>	M	9999	LIN-DTM-RFF-BUS-FCA-SG5-SG6-SG7-SG8-SG9-SG10-SG11			
A group of segments containing information regarding the credit side of the transaction and details which are pertinent to all direct debits specified within the group. Certain payment details may be provided either in segment group 4 or in segment group 11, but not in both.						
<b>SG9</b>	C	10	GIS-MOA-LOC-NAD-RCS-FTX			
A group of segments providing information for subsequent use by regulatory authorities requiring statistical and other types of data. It also identifies the regulatory authority for which the information is intended followed by the information itself.						
27	<b>RCS</b>	C	1	Requirements and conditions		
To specify sector/subject requirements and conditions.						
Business Term	DE	EDIFACT	Format	St	*	Description
	7293	Sector area identification code qualifier	an..3	M	*	25 Banking sector
	C550	Requirement/condition identification		A		
	7295	Requirement or condition description identifier	an..17	M		As no EDIFACT code values exist for this data element it is recommended that nationally agreed codes be formulated to identify the requirements and conditions possible due to regulatory requirements.
	1131	Code list identification code	an..17	O		
	3055	Code list responsible agency code	an..3	D		86 Assigned by party originating the message
	7294	Requirement or condition description	an..35	O		
This segment is used to indicate any requirements and conditions related to the transaction which is being reported to the regulatory authorities. Example: Example: RCS+25+AB1:23:86:X' Example: RCS+25+AB1::86'						

Max. Occ. = Maximum Occurrence, St = Status, \* = Restricted Codes

Status: M=Mandatory, R=Required, O=Optional, C=Conditional, D=Dependent, A=Advised, N=Not used

## Segment Layout

No. Seg	St	Max. Occ.				Description
<b>SG4</b>	M	9999	LIN-DTM-RFF-BUS-FCA-SG5-SG6-SG7-SG8-SG9-SG10-SG11			A group of segments containing information regarding the credit side of the transaction and details which are pertinent to all direct debits specified within the group. Certain payment details may be provided either in segment group 4 or in segment group 11, but not in both.
<b>SG9</b>	C	10	GIS-MOA-LOC-NAD-RCS-FTX			A group of segments providing information for subsequent use by regulatory authorities requiring statistical and other types of data. It also identifies the regulatory authority for which the information is intended followed by the information itself.
28	<b>FTX</b>	C	10	Free text		To provide free form or coded text information.
Business Term	DE	EDIFACT	Format	St	*	Description
	4451	Text subject code qualifier	an..3	M	*	REG <b>Regulatory information</b>
	4453	Free text function code	an..3	N		
	C107	Text reference		D		This composite is only used when trading partners have agreed to use mutually defined code values.
	4441	Free text value code	an..17	M		A code identifying standard text agreed between partners.
	1131	Code list identification code	an..17	O		
	3055	Code list responsible agency code	an..3	D		
	C108	Text literal		D		This composite is only used if coded text can not be used.
	4440	Free text value	an..51	M		
	4440	Free text value	an..51	O		
	4440	Free text value	an..51	O		
	4440	Free text value	an..51	O		
	4440	Free text value	an..51	O		
	3453	Language name code	an..3	D		ISO 639 two alpha code. This data element is only used when non coded free text has been provided in data element C108.
<p>This segment is used to provide free or coded text information required by the regulatory authorities. The form and content of this segment is dependent upon the central bank or regulatory authority's requirements.</p> <p>Use of this segment in free form is not recommended since in most cases it inhibits automatic processing of the direct debit message. Coded references to standard texts is an available functionality which enables automatic processing and reduces transmission and processing overheads. Standard texts should be mutually defined among trading partners and can be used to cover legal and other requirements.</p>						

Max. Occ. = Maximum Occurrence, St = Status, \* = Restricted Codes

Status: M=Mandatory, R=Required, O=Optional, C=Conditional, D=Dependent, A=Advised, N=Not used



## Segment Layout

---

Example:

Example: FTX+REG++1E:23:2+X:X:X:X+AA'

Example: FTX+REG+++SUBJECT TO EUROPEAN CENTRAL BANK REGULATIONS'

## Segment Layout

No. Seg	St	Max. Occ.				
<b>SG4</b>	M	9999	LIN-DTM-RFF-BUS-FCA-SG5-SG6-SG7-SG8-SG9-SG10-SG11			
A group of segments containing information regarding the credit side of the transaction and details which are pertinent to all direct debits specified within the group. Certain payment details may be provided either in segment group 4 or in segment group 11, but not in both.						
<b>SG10</b>	C	1	PRC-FTX			
A group of segments giving information in free form about the purpose of the direct debit from the creditor to the debtors.						
29	<b>PRC</b>	M	1	Process identification		
To identify a process.						
Business Term	DE	EDIFACT	Format	St	*	Description
	C242	Process type and description		R		
	7187	Process type description code	an..17	M	*	11 Processing of unstructured information
This segment is used to provide processing information for each beneficiary of the debit instructions. Example: Example: PRC+11 ' Example: PRC+11 '						

Max. Occ. = Maximum Occurrence, St = Status, \* = Restricted Codes

Status: M=Mandatory, R=Required, O=Optional, C=Conditional, D=Dependent, A=Advised, N=Not used

## Segment Layout

No. Seg	St	Max. Occ.				
<b>SG4</b>	M	9999	LIN-DTM-RFF-BUS-FCA-SG5-SG6-SG7-SG8-SG9-SG10-SG11			
A group of segments containing information regarding the credit side of the transaction and details which are pertinent to all direct debits specified within the group. Certain payment details may be provided either in segment group 4 or in segment group 11, but not in both.						
<b>SG10</b>	C	1	PRC-FTX			
A group of segments giving information in free form about the purpose of the direct debit from the creditor to the debtors.						
30	<b>FTX</b>	M	1	Free text		
To provide free form or coded text information.						
Business Term	DE	EDIFACT	Format	St	*	Description
	4451	Text subject code qualifier	an..3	M		PMD Payment detail/ remittance information
	4453	Free text function code	an..3	N		
	C107	Text reference		D		This composite is only used when trading partners have agreed to use mutually defined code values.
	4441	Free text value code	an..17	M		A code identifying standard text agreed between trading partners.
	1131	Code list identification code	an..17	O		
	3055	Code list responsible agency code	an..3	D		
	C108	Text literal		D		This composite is only used if coded text can not be used.
	4440	Free text value	an..51	M		
	4440	Free text value	an..51	O		
	4440	Free text value	an..51	O		
	4440	Free text value	an..51	O		
	4440	Free text value	an..51	O		
	3453	Language name code	an..3	D		ISO 639 two alpha code. This data element is only used when non coded free text has been provided in data element C108.
<p>This segment is used to provide free or coded text information related to the processing of the payment.</p> <p>Use of this segment in free form is not recommended since in most cases it inhibits automatic processing of the direct debit message. Coded references to standard texts is an available functionality which enables automatic processing and reduces transmission and processing overheads. Standard texts should be mutually defined among trading partners and can be used to cover legal and other requirements.</p>						

Max. Occ. = Maximum Occurrence, St = Status, \* = Restricted Codes

Status: M=Mandatory, R=Required, O=Optional, C=Conditional, D=Dependent, A=Advised, N=Not used

## Segment Layout

---

Example:

Example: FTX+AAG++1E:23:2+BEWARE EMBARGO PAYMENTS:X:X:X:X+EN'

Example: FTX+PMD+++EMBARGO PAYMENT RESTRICTIONS IN FORCE+EN'

Max. Occ. = Maximum Occurrence, St = Status, \* = Restricted Codes

Status: M=Mandatory, R=Required, O=Optional, C=Conditional, D=Dependent, A=Advised, N=Not used

## Segment Layout

No. Seg	St	Max. Occ.				
<b>SG4</b>	M	9999	LIN-DTM-RFF-BUS-FCA-SG5-SG6-SG7-SG8-SG9-SG10-SG11			
A group of segments containing information regarding the credit side of the transaction and details which are pertinent to all direct debits specified within the group. Certain payment details may be provided either in segment group 4 or in segment group 11, but not in both.						
<b>SG11</b>	M	99999	SEQ-MOA-DTM-RFF-FCA-SG12-SG13-SG14-SG15-SG16			
This Segment Group contains information regarding the debtor(s) of the direct debit. Certain payment details may be provided either in Segment Group 11 or in Segment Group 4, but not in both.						
31	<b>SEQ</b>	M	1	Sequence details		
To provide details relating to the sequence.						
Business Term	DE	EDIFACT	Format	St	*	Description
	1229	Action request/ notification description code	an..3	N		
	C286	Sequence information		R		
	1050	Sequence position identifier	an..10	M		
This segment is used to identify the start of the credit side of the transaction (level C) by means of a sequence number within the current line number. The sequence number should be incremented by one for each occurrence of a new line number (in LIN segment). Example: Example: SEQ++1 ' Example: SEQ++1 '						

Max. Occ. = Maximum Occurrence, St = Status, \* = Restricted Codes

Status: M=Mandatory, R=Required, O=Optional, C=Conditional, D=Dependent, A=Advised, N=Not used

## Segment Layout

No. Seg	St	Max. Occ.				
<b>SG4</b>	M	9999	LIN-DTM-RFF-BUS-FCA-SG5-SG6-SG7-SG8-SG9-SG10-SG11			
<p>A group of segments containing information regarding the credit side of the transaction and details which are pertinent to all direct debits specified within the group. Certain payment details may be provided either in segment group 4 or in segment group 11, but not in both.</p>						
<b>SG11</b>	M	99999	SEQ-MOA-DTM-RFF-FCA-SG12-SG13-SG14-SG15-SG16			
<p>This Segment Group contains information regarding the debtor(s) of the direct debit. Certain payment details may be provided either in Segment Group 11 or in Segment Group 4, but not in both.</p>						
32	<b>MOA</b>	M 1	Monetary amount			
<p>To specify a monetary amount.</p>						
Business Term	DE	EDIFACT	Format	St	*	Description
	C516	Monetary amount		M		
	5025	Monetary amount type code qualifier	an..3	M	*	9 Amount due/ amount payable 57 Equivalent amount
	5004	Monetary amount	n..35	R		
	6345	Currency identification code	an..3	D		ISO 4217 three alpha code
<p>This segment is used to specify the payment amount for the credit instruction.                      DE 5025 and 5345: When code value '9' is used in data element 5025 then the currency code specified in data element 5345 must be the same as that specified in DE 6345 of the MOA segment in segment group 5.                      Example:                      Example: MOA+9:122.34:EUR '                      Example: MOA+9:430000:EUR '</p>						

Max. Occ. = Maximum Occurrence, St = Status, \* = Restricted Codes  
 Status: M=Mandatory, R=Required, O=Optional, C=Conditional, D=Dependent, A=Advised, N=Not used

**Segment Layout**

No. Seg	St	Max. Occ.				
<b>SG4</b>	M	9999	LIN-DTM-RFF-BUS-FCA-SG5-SG6-SG7-SG8-SG9-SG10-SG11			
A group of segments containing information regarding the credit side of the transaction and details which are pertinent to all direct debits specified within the group. Certain payment details may be provided either in segment group 4 or in segment group 11, but not in both.						
<b>SG11</b>	M	99999	SEQ-MOA-DTM-RFF-FCA-SG12-SG13-SG14-SG15-SG16			
This Segment Group contains information regarding the debtor(s) of the direct debit. Certain payment details may be provided either in Segment Group 11 or in Segment Group 4, but not in both.						
33	<b>DTM</b>	C 1	Date/time/period			
To specify date, and/or time, or period.						
Business Term	DE	EDIFACT	Format	St	*	Description
	C507	Date/time/period		M		
	2005	Date or time or period function code qualifier	an..3	M	*	434 Maturity date 448 Referenced item creation date XF2 Date of issue and maturity (SWIFT Code)
	2380	Date or time or period value	an..35	R		
	2379	Date or time or period format code	an..3	R		102 CCYYMMDD 203 CCYYMMDDHHMM
This segment is used to specify dates relevant to the debtor's side of the direct debit transaction. Example: Example: DTM+434:19980831:102' Example: DTM+XF2:20000126:102'						

Max. Occ. = Maximum Occurrence, St = Status, \* = Restricted Codes

Status: M=Mandatory, R=Required, O=Optional, C=Conditional, D=Dependent, A=Advised, N=Not used

## Segment Layout

No. Seg	St	Max. Occ.				
<b>SG4</b>	M	9999	LIN-DTM-RFF-BUS-FCA-SG5-SG6-SG7-SG8-SG9-SG10-SG11			
A group of segments containing information regarding the credit side of the transaction and details which are pertinent to all direct debits specified within the group. Certain payment details may be provided either in segment group 4 or in segment group 11, but not in both.						
<b>SG11</b>	M	99999	SEQ-MOA-DTM-RFF-FCA-SG12-SG13-SG14-SG15-SG16			
This Segment Group contains information regarding the debtor(s) of the direct debit. Certain payment details may be provided either in Segment Group 11 or in Segment Group 4, but not in both.						
34	<b>RFF</b>	C	3	Reference		
To specify a reference.						
Business Term	DE	EDIFACT	Format	St	*	Description
	C506	Reference		M		
	1153	Reference code qualifier	an..3	M		AHM Debtor's reference number ANZ Direct debit reference AOA Documentary payment reference CR Customer reference number PQ Payment reference RA Remittance advice number
	1154	Reference identifier	an..70	R		
This segment is used to identify the individual direct debit transaction in a way which is meaningful to the creditor and the debtor. Example: Example: RFF+CR:12345 ' Example: RFF+ANZ:43155836 '						

Max. Occ. = Maximum Occurrence, St = Status, \* = Restricted Codes

Status: M=Mandatory, R=Required, O=Optional, C=Conditional, D=Dependent, A=Advised, N=Not used



## Segment Layout

No. Seg	St	Max. Occ.				
<b>SG4</b>	M	9999	LIN-DTM-RFF-BUS-FCA-SG5-SG6-SG7-SG8-SG9-SG10-SG11			
A group of segments containing information regarding the credit side of the transaction and details which are pertinent to all direct debits specified within the group. Certain payment details may be provided either in segment group 4 or in segment group 11, but not in both.						
<b>SG11</b>	M	99999	SEQ-MOA-DTM-RFF-FCA-SG12-SG13-SG14-SG15-SG16			
This Segment Group contains information regarding the debtor(s) of the direct debit. Certain payment details may be provided either in Segment Group 11 or in Segment Group 4, but not in both.						
35	<b>FCA</b>	C 1	Financial charges allocation			
Description of allocation of charges.						
Business Term	DE	EDIFACT	Format	St	*	Description
	4471	Settlement means code	an..3	M	*	13 All charges borne by payee 14 Each pay own cost 15 All charges borne by payor When using code value '15' in this data element it is not recommended that C878 be used.
	C878	Charge/allowance account		O		
	3434	Institution branch identifier	an..17	M		
	1131	Code list identification code	an..17	O		25 Bank identification 154 Bank branch sorting identification
	3055	Code list responsible agency code	an..3	D		5 ISO (International Organization for Standardization)
	3194	Account holder identifier	an..35	O		
	6345	Currency identification code	an..3	O		ISO 4217 three alpha
<p>This segment is used to identify the basis on which any charges are allocated and the account (of the debtor) to which the charges should be directed.</p> <p>This segment must not be used if the charge allocation details have already been provided in the FCA segment in group 4.</p> <p>Example:</p> <p>Example: FCA+13+X:23:2:X:ARS '</p> <p>Example: FCA+15+DRESDEFF666:25:5 '</p>						

Max. Occ. = Maximum Occurrence, St = Status, \* = Restricted Codes

Status: M=Mandatory, R=Required, O=Optional, C=Conditional, D=Dependent, A=Advised, N=Not used

## Segment Layout

No. Seg	St	Max. Occ.	
<b>SG4</b>	M	9999	LIN-DTM-RFF-BUS-FCA-SG5-SG6-SG7-SG8-SG9-SG10-SG11
<p>A group of segments containing information regarding the credit side of the transaction and details which are pertinent to all direct debits specified within the group. Certain payment details may be provided either in segment group 4 or in segment group 11, but not in both.</p>			
<b>SG11</b>	M	99999	SEQ-MOA-DTM-RFF-FCA-SG12-SG13-SG14-SG15-SG16
<p>This Segment Group contains information regarding the debtor(s) of the direct debit. Certain payment details may be provided either in Segment Group 11 or in Segment Group 4, but not in both.</p>			
<b>SG12</b>	C	3	FII
<p>A group of segments containing the debtor's bank and the account and if necessary up to two intermediary banks.</p>			
36	<b>FII</b>	M 1	Financial institution information
<p>To identify an account and a related financial institution.</p>			

Business Term	DE	EDIFACT	Format	St	*	Description
	3035	Party function code qualifier	an..3	M		DBB Debtor's bank (SWIFT Code)
	C078	Account holder identification		R		
	3194	Account holder identifier	an..35	R		Beneficiary account number.
	3192	Account holder name	an..35	O		
	3192	Account holder name	an..35	O		
	6345	Currency identification code	an..3	O		ISO 4217 three alpha
	C088	Institution identification		D		In some countries it is possible to identify within the account number the institution name and branch. Where this is possible the composite C088 will not be required. For international transactions it is recommended that the need for composite C088 should be checked before sending the message.
	3433	Institution name code	an..11	A		
	1131	Code list identification code	an..17	O		25 Bank identification
	3055	Code list responsible agency code	an..3	D		5 ISO (International Organization for Standardization)
	3434	Institution branch identifier	an..17	O		
	1131	Code list identification code	an..17	O		
		Code list responsible				

Max. Occ. = Maximum Occurrence, St = Status, \* = Restricted Codes

Status: M=Mandatory, R=Required, O=Optional, C=Conditional, D=Dependent, A=Advised, N=Not used

## Segment Layout

Business Term	DE	EDIFACT	Format	St	*	Description
	3055	agency code	an..3	D		5 ISO (International Organization for Standardization)
	3432	Institution name	an..70	O		
	3436	Institution branch location name	an..70	O		
	3207	Country name code	an..3	O		ISO 3166 two alpha code

This segment is used to identify the financial institution and account number of the debtor. The preferred way to identify a bank and its branch is in machine readable format using data elements 3433 and 3434. When using C088 it is recommended that if data element 3433 is not used that 3432 be used, and that when data element 3434 is not used that data element 3436 be used.

Example:

The debtor's bank account details is identified as being N Geiss with a bank account number of 994-3277711. In this example the identity of the bank is contained in the account number.

Example: FII+DBB+12345:N GEISS:X:USD+BK:23:2:50040000:25:2:X:X+AD'

Example: FII+DBB+994-3277711:N GEISS'

Max. Occ. = Maximum Occurrence, St = Status, \* = Restricted Codes

Status: M=Mandatory, R=Required, O=Optional, C=Conditional, D=Dependent, A=Advised, N=Not used

## Segment Layout

No. Seg	St	Max. Occ.				
<b>SG4</b>	M	9999	LIN-DTM-RFF-BUS-FCA-SG5-SG6-SG7-SG8-SG9-SG10-SG11			
A group of segments containing information regarding the credit side of the transaction and details which are pertinent to all direct debits specified within the group. Certain payment details may be provided either in segment group 4 or in segment group 11, but not in both.						
<b>SG11</b>	M	99999	SEQ-MOA-DTM-RFF-FCA-SG12-SG13-SG14-SG15-SG16			
This Segment Group contains information regarding the debtor(s) of the direct debit. Certain payment details may be provided either in Segment Group 11 or in Segment Group 4, but not in both.						
<b>SG13</b>	C	3	NAD			
A group of segments identifying the name and address of the debtor and one contact party.						
37	<b>NAD</b>	M	1	Name and address		
To specify the name/address and their related function, either by C082 only and/or unstructured by C058 or structured by C080 thru 3207.						
Business Term	DE	EDIFACT	Format	St	*	Description
	3035	Party function code qualifier	an..3	M		BY Buyer HX Debtor (SWIFT Code) PL Payor P1 Contact party 1 SU Supplier
	C082	Party identification details		A		
	3039	Party identifier	an..35	M		
	1131	Code list identification code	an..17	O		
	3055	Code list responsible agency code	an..3	D		9 GS1
	C058	Name and address		O		This composite may only be used to fulfill the requirements of directive 2003/58/EC, article 4.
	3124	Name and address description	an..35	M		
	3124	Name and address description	an..35	O		
	3124	Name and address description	an..35	O		
	3124	Name and address description	an..35	O		
	3124	Name and address description	an..35	O		
	C080	Party name		D		
	3036	Party name	an..35	M		Party name in clear text.
	3036	Party name	an..35	O		

Max. Occ. = Maximum Occurrence, St = Status, \* = Restricted Codes

Status: M=Mandatory, R=Required, O=Optional, C=Conditional, D=Dependent, A=Advised, N=Not used

**Segment Layout**

Business Term	DE	EDIFACT	Format	St	*	Description
	3036	Party name	an..35	O		
	3036	Party name	an..35	O		
	3036	Party name	an..35	O		
	3045	Party name format code	an..3	O		
	C059	Street		D		
	3042	Street and number or post office box identifier	an..35	M		Building Name/Number and Street Name
	3042	Street and number or post office box identifier	an..35	O		
	3042	Street and number or post office box identifier	an..35	O		
	3042	Street and number or post office box identifier	an..35	O		
	3164	City name	an..35	D		City/Town name, clear text
	C819	Country sub-entity details		D		
	3229	Country sub-entity name code	an..9	O		
	1131	Code list identification code	an..17	O		
	3055	Code list responsible agency code	an..3	O		
	3228	Country sub-entity name	an..70	O		County/State, clear text.
	3251	Postal identification code	an..17	D		Postal code
	3207	Country name code	an..3	D		ISO 3166 two alpha code

This segment is used to identify the debtor in the direct debit transactions and is passed on unchanged through the banking chain.

Example:

NAD+HX+5412345000020::9'

The debtor is identified using the Global Location Number GLN 5412345000020.

Dependency Notes:

The following composites and data elements are only used when a coded name and address can not be used. The affected composites and data elements are as follows;

C080 - C059 - 3164 - C819 - 3251 - 3207

Example: NAD+BY+123456789:23:2+X:::X+X:X:X:X:1+X:X:X+X+X:23:2:X+X+AD'

Max. Occ. = Maximum Occurrence, St = Status, \* = Restricted Codes

Status: M=Mandatory, R=Required, O=Optional, C=Conditional, D=Dependent, A=Advised, N=Not used

## Segment Layout

No. Seg	St	Max. Occ.				
<b>SG4</b>	M	9999	LIN-DTM-RFF-BUS-FCA-SG5-SG6-SG7-SG8-SG9-SG10-SG11			
A group of segments containing information regarding the credit side of the transaction and details which are pertinent to all direct debits specified within the group. Certain payment details may be provided either in segment group 4 or in segment group 11, but not in both.						
<b>SG11</b>	M	99999	SEQ-MOA-DTM-RFF-FCA-SG12-SG13-SG14-SG15-SG16			
This Segment Group contains information regarding the debtor(s) of the direct debit. Certain payment details may be provided either in Segment Group 11 or in Segment Group 4, but not in both.						
<b>SG14</b>	C	3	INP-FTX-DTM			
A group of segments containing instructions from the creditor relating to parties identified in the NAD and FII segments. It specifies action to be taken by the identified parties, and the date (and optionally time) by which such actions needs to be taken.						
38	<b>INP</b>	M	1	Parties and instruction		
To specify parties to an instruction, the instruction, or both.						
Business Term	DE	EDIFACT	Format	St	*	Description
	C849	Parties to instruction		A		
	3301	Enacting party identifier	an..35	M		8 Debtor's bank
	3285	Instruction receiving party identifier	an..35	O		5 Contact party 1 15 Debtor
	C522	Instruction		O		
	4403	Instruction type code qualifier	an..3	M		2 Party instructions
	4401	Instruction description code	an..3	O		AD Advise AP Advise by phone AJ Advise by fax (SWIFT Code) EX Expedite
	1131	Code list identification code	an..17	N		
	3055	Code list responsible agency code	an..3	O		
	4400	Instruction description	an..35	O		
This segment is used to identify the party who must carry out an instruction from the creditor, and the party to whom the instruction is intended.						
This segment should not be used if the INP segment in segment group 8 was used.						
DE's 3301 and 3285: As these data elements are being used to provide coded information it is recommended that their format and length be restricted to an..3.						
Example:						
Example: INP+3:5+1:AD::2:X'						
Example: INP+8+2:AD'						

Max. Occ. = Maximum Occurrence, St = Status, \* = Restricted Codes

Status: M=Mandatory, R=Required, O=Optional, C=Conditional, D=Dependent, A=Advised, N=Not used

## Segment Layout

No. Seg	St	Max. Occ.				
<b>SG4</b>	M	9999	LIN-DTM-RFF-BUS-FCA-SG5-SG6-SG7-SG8-SG9-SG10-SG11			
A group of segments containing information regarding the credit side of the transaction and details which are pertinent to all direct debits specified within the group. Certain payment details may be provided either in segment group 4 or in segment group 11, but not in both.						
<b>SG11</b>	M	99999	SEQ-MOA-DTM-RFF-FCA-SG12-SG13-SG14-SG15-SG16			
This Segment Group contains information regarding the debtor(s) of the direct debit. Certain payment details may be provided either in Segment Group 11 or in Segment Group 4, but not in both.						
<b>SG14</b>	C	3	INP-FTX-DTM			
A group of segments containing instructions from the creditor relating to parties identified in the NAD and FII segments. It specifies action to be taken by the identified parties, and the date (and optionally time) by which such actions needs to be taken.						
39	<b>FTX</b>	C	1	Free text		
To provide free form or coded text information.						
Business Term	DE	EDIFACT	Format	St	*	Description
	4451	Text subject code qualifier	an..3	M		AAG Party instructions
	4453	Free text function code	an..3	N		
	C107	Text reference		D		This composite is only used when trading partners have agreed to use mutually defined code values.
	4441	Free text value code	an..17	M		Coded reference to standard text between partners.
	1131	Code list identification code	an..17	O		
	3055	Code list responsible agency code	an..3	D		86 Assigned by party originating the message
	C108	Text literal		D		This composite is only used if coded text can not be used.
	4440	Free text value	an..51	M		
	4440	Free text value	an..51	O		
	4440	Free text value	an..51	O		
	4440	Free text value	an..51	O		
	4440	Free text value	an..51	O		
	3453	Language name code	an..3	D		ISO 639 two alpha code. This data element is only used when non coded free text has been provided in data element C108.
This segment is used to provide additional coded or free text instructions to those provided in the INP segment.						

Max. Occ. = Maximum Occurrence, St = Status, \* = Restricted Codes

Status: M=Mandatory, R=Required, O=Optional, C=Conditional, D=Dependent, A=Advised, N=Not used

## Segment Layout

---

Use of this segment in free form is not recommended since in most cases it inhibits automatic processing of the direct debit message. Coded references to standard texts is an available functionality which enables automatic processing and reduces transmission and processing overheads. Standard texts should be mutually defined among trading partners and can be used to cover legal and other requirements.

Example:

Example: FTX+AAG++1E:23:2+BEWARE EMBARGO PAYMENTS:X:X:X:X+EN'

Example: FTX+AAG+++EMBARGO REGULATIONS+EN'



**Segment Layout**

No. Seg	St	Max. Occ.				
<b>SG4</b>	M	9999	LIN-DTM-RFF-BUS-FCA-SG5-SG6-SG7-SG8-SG9-SG10-SG11			
<p>A group of segments containing information regarding the credit side of the transaction and details which are pertinent to all direct debits specified within the group. Certain payment details may be provided either in segment group 4 or in segment group 11, but not in both.</p>						
<b>SG11</b>	M	99999	SEQ-MOA-DTM-RFF-FCA-SG12-SG13-SG14-SG15-SG16			
<p>This Segment Group contains information regarding the debtor(s) of the direct debit. Certain payment details may be provided either in Segment Group 11 or in Segment Group 4, but not in both.</p>						
<b>SG14</b>	C	3	INP-FTX-DTM			
<p>A group of segments containing instructions from the creditor relating to parties identified in the NAD and FII segments. It specifies action to be taken by the identified parties, and the date (and optionally time) by which such actions needs to be taken.</p>						
40	<b>DTM</b>	C	2	Date/time/period		
<p>To specify date, and/or time, or period.</p>						
Business Term	DE	EDIFACT	Format	St	*	Description
	C507	Date/time/period		M		
	2005	Date or time or period function code qualifier	an..3	M		9 Processing date/time 174 Advise after date/time 175 Advise before date/time 176 Advise completed date/time 177 Advise on date/time
	2380	Date or time or period value	an..35	R		
	2379	Date or time or period format code	an..3	R		102 CCYYMMDD 203 CCYYMMDDHHMM 713 YYMMDDHHMM-YYMMDDHHMM
<p>This segment is used to specify the earliest and latest dates by which the instructions must be carried out.                      Example:                      Advise before 10am on the 17th of June 2000.                       Example: DTM+2:X:2'                      Example: DTM+175:200006171000:203'</p>						

Max. Occ. = Maximum Occurrence, St = Status, \* = Restricted Codes  
 Status: M=Mandatory, R=Required, O=Optional, C=Conditional, D=Dependent, A=Advised, N=Not used

## Segment Layout

No. Seg	St	Max. Occ.				
<b>SG4</b>	M	9999	LIN-DTM-RFF-BUS-FCA-SG5-SG6-SG7-SG8-SG9-SG10-SG11			
A group of segments containing information regarding the credit side of the transaction and details which are pertinent to all direct debits specified within the group. Certain payment details may be provided either in segment group 4 or in segment group 11, but not in both.						
<b>SG11</b>	M	99999	SEQ-MOA-DTM-RFF-FCA-SG12-SG13-SG14-SG15-SG16			
This Segment Group contains information regarding the debtor(s) of the direct debit. Certain payment details may be provided either in Segment Group 11 or in Segment Group 4, but not in both.						
<b>SG15</b>	C	10	GIS-MOA-LOC-NAD-RCS-FTX			
A group of segments providing information for subsequent use by regulatory authorities requiring statistical and other types of data. It also identifies the regulatory authority for which the information is intended followed by the information itself.						
41	<b>GIS</b>	M 1	General indicator			
To transmit a processing indicator.						
Notes:						
1. This segment will be removed effective with directory D.02B.						
Business Term	DE	EDIFACT	Format	St	*	Description
	C529	Processing indicator		M		
	7365	Processing indicator description code	an..3	M	*	10 Declaration requested
This segment is used to indicate that the information contained in the following segments will be passed on to and processed by the central and regulatory party identified in the NAD segment. This segment should not be used if the GIS segment in segment group 9 has already been used. Note: The use of this segment group is subject to domestic regulations stipulated by regulatory authorities, e.g. Central Bank. Example: Example: GIS+10' Example: GIS+10'						

Max. Occ. = Maximum Occurrence, St = Status, \* = Restricted Codes

Status: M=Mandatory, R=Required, O=Optional, C=Conditional, D=Dependent, A=Advised, N=Not used

## Segment Layout

No. Seg	St	Max. Occ.				
<b>SG4</b>	M	9999	LIN-DTM-RFF-BUS-FCA-SG5-SG6-SG7-SG8-SG9-SG10-SG11			
A group of segments containing information regarding the credit side of the transaction and details which are pertinent to all direct debits specified within the group. Certain payment details may be provided either in segment group 4 or in segment group 11, but not in both.						
<b>SG11</b>	M	99999	SEQ-MOA-DTM-RFF-FCA-SG12-SG13-SG14-SG15-SG16			
This Segment Group contains information regarding the debtor(s) of the direct debit. Certain payment details may be provided either in Segment Group 11 or in Segment Group 4, but not in both.						
<b>SG15</b>	C	10	GIS-MOA-LOC-NAD-RCS-FTX			
A group of segments providing information for subsequent use by regulatory authorities requiring statistical and other types of data. It also identifies the regulatory authority for which the information is intended followed by the information itself.						
42	<b>MOA</b>	C	1	Monetary amount		
To specify a monetary amount.						
Business Term	DE	EDIFACT	Format	St	*	Description
	C516	Monetary amount		M		
	5025	Monetary amount type code qualifier	an..3	M		9 Amount due/amount payable
	5004	Monetary amount	n..35	R		
	6345	Currency identification code	an..3	O		ISO 4217 three alpha code
	6343	Currency type code qualifier	an..3	O		11 Payment currency
This segment is used to specify monetary amounts which must be reported to the regulatory party identified in the NAD segment. Example: Example: MOA+139:122.34:EUR:11 ' Example: MOA+9:430000:EUR:11 '						

Max. Occ. = Maximum Occurrence, St = Status, \* = Restricted Codes

Status: M=Mandatory, R=Required, O=Optional, C=Conditional, D=Dependent, A=Advised, N=Not used

## Segment Layout

No. Seg	St	Max. Occ.				
<b>SG4</b>	M	9999	LIN-DTM-RFF-BUS-FCA-SG5-SG6-SG7-SG8-SG9-SG10-SG11			
A group of segments containing information regarding the credit side of the transaction and details which are pertinent to all direct debits specified within the group. Certain payment details may be provided either in segment group 4 or in segment group 11, but not in both.						
<b>SG11</b>	M	99999	SEQ-MOA-DTM-RFF-FCA-SG12-SG13-SG14-SG15-SG16			
This Segment Group contains information regarding the debtor(s) of the direct debit. Certain payment details may be provided either in Segment Group 11 or in Segment Group 4, but not in both.						
<b>SG15</b>	C	10	GIS-MOA-LOC-NAD-RCS-FTX			
A group of segments providing information for subsequent use by regulatory authorities requiring statistical and other types of data. It also identifies the regulatory authority for which the information is intended followed by the information itself.						
43	<b>LOC</b>	C	2	Place/location identification		
To identify a place or a location and/or related locations.						
Business Term	DE	EDIFACT	Format	St	*	Description
	3227	Location function code qualifier	an..3	M		27 Country of origin 28 Country of destination of goods 39 Country of production 40 Country of trading
	C517	Location identification		A		
	3225	Location name code	an..25	A		
	1131	Code list identification code	an..17	O		
	3055	Code list responsible agency code	an..3	D		5 ISO (International Organization for Standardization) DE 3055 must be used if DE 3225 is used and does not contain an UN/LOCODE.
	3224	Location name	an..25	O		
	C519	Related location one identification		N		
	3223	First related location name code	an..25			
	C553	Related location two identification		O		
	3233	Second related location name code	an..25	O		
	1131	Code list identification code	an..17	O		
	3055	Code list responsible agency code	an..3	D		DE 3055 must be used if DE 3233 is used and does not contain an UN/LOCODE.

Max. Occ. = Maximum Occurrence, St = Status, \* = Restricted Codes

Status: M=Mandatory, R=Required, O=Optional, C=Conditional, D=Dependent, A=Advised, N=Not used

## Segment Layout

Business Term	DE	EDIFACT	Format	St	*	Description
	3232	Second related location name	an..70	O		
<p>This segment is used to indicate any locations relevant to the regulatory party identified in the NAD segment.                      Example:                      Goods were produced in Belgium.                      Example: LOC+39+BE:23:2:X++LONDEC:23:2:X'                      Example: LOC+39+BE'</p>						

Max. Occ. = Maximum Occurrence, St = Status, \* = Restricted Codes  
 Status: M=Mandatory, R=Required, O=Optional, C=Conditional, D=Dependent, A=Advised, N=Not used

## Segment Layout

No. Seg	St	Max. Occ.	
<b>SG4</b>	M	9999	LIN-DTM-RFF-BUS-FCA-SG5-SG6-SG7-SG8-SG9-SG10-SG11
A group of segments containing information regarding the credit side of the transaction and details which are pertinent to all direct debits specified within the group. Certain payment details may be provided either in segment group 4 or in segment group 11, but not in both.			
<b>SG11</b>	M	99999	SEQ-MOA-DTM-RFF-FCA-SG12-SG13-SG14-SG15-SG16
This Segment Group contains information regarding the debtor(s) of the direct debit. Certain payment details may be provided either in Segment Group 11 or in Segment Group 4, but not in both.			
<b>SG15</b>	C	10	GIS-MOA-LOC-NAD-RCS-FTX
A group of segments providing information for subsequent use by regulatory authorities requiring statistical and other types of data. It also identifies the regulatory authority for which the information is intended followed by the information itself.			
44	<b>NAD</b>	C 1	Name and address
To specify the name/address and their related function, either by C082 only and/or unstructured by C058 or structured by C080 thru 3207.			

Business Term	DE	EDIFACT	Format	St	*	Description
	3035	Party function code qualifier	an..3	M	*	RA Central bank or regulatory authority
	C082	Party identification details		A		
	3039	Party identifier	an..35	M		
	1131	Code list identification code	an..17	O		
	3055	Code list responsible agency code	an..3	D		9 GS1
	C058	Name and address		O		This composite may only be used to fulfill the requirements of directive 2003/58/EC, article 4.
	3124	Name and address description	an..35	M		
	3124	Name and address description	an..35	O		
	3124	Name and address description	an..35	O		
	3124	Name and address description	an..35	O		
	3124	Name and address description	an..35	O		
	C080	Party name		D		
	3036	Party name	an..35	M		Party name in clear text.
	3036	Party name	an..35	O		
	3036	Party name	an..35	O		
		Party name				

Max. Occ. = Maximum Occurrence, St = Status, \* = Restricted Codes

Status: M=Mandatory, R=Required, O=Optional, C=Conditional, D=Dependent, A=Advised, N=Not used

**Segment Layout**

Business Term	DE	EDIFACT	Format	St	*	Description
	3036		an..35	O		
	3036	Party name	an..35	O		
	3045	Party name format code	an..3	O		
	C059	Street		D		
	3042	Street and number or post office box identifier	an..35	M		Building Name/Number and Street
	3042	Street and number or post office box identifier	an..35	O		
	3042	Street and number or post office box identifier	an..35	O		
	3042	Street and number or post office box identifier	an..35	O		
	3164	City name	an..35	D		City/town name, clear text.
	C819	Country sub-entity details		D		
	3229	Country sub-entity name code	an..9	O		
	1131	Code list identification code	an..17	O		
	3055	Code list responsible agency code	an..3	O		
	3228	Country sub-entity name	an..70	O		County/State, clear text.
	3251	Postal identification code	an..17	D		Postal code.
	3207	Country name code	an..3	D		ISO 3166 two alpha code

This segment is used to identify the central and regulatory authority specifying the regulatory information detailed in the GIS and FTX segments.

Example:

Dependency Notes:

The following composites and data elements are only used when a coded name and address can not be used. The affected composites and data elements are as follows;

C080 - C059 - 3164 - C819 - 3251 - 3207

Example: NAD+RA+272971234:23:2+X:::X+X:X:X:X:X:1+X:X:X+X+X:23:2:X+X+AD'

Example: NAD+RA+5422331123459::9'

Max. Occ. = Maximum Occurrence, St = Status, \* = Restricted Codes

Status: M=Mandatory, R=Required, O=Optional, C=Conditional, D=Dependent, A=Advised, N=Not used

## Segment Layout

No. Seg	St	Max. Occ.				
<b>SG4</b>	M	9999	LIN-DTM-RFF-BUS-FCA-SG5-SG6-SG7-SG8-SG9-SG10-SG11			
A group of segments containing information regarding the credit side of the transaction and details which are pertinent to all direct debits specified within the group. Certain payment details may be provided either in segment group 4 or in segment group 11, but not in both.						
<b>SG11</b>	M	99999	SEQ-MOA-DTM-RFF-FCA-SG12-SG13-SG14-SG15-SG16			
This Segment Group contains information regarding the debtor(s) of the direct debit. Certain payment details may be provided either in Segment Group 11 or in Segment Group 4, but not in both.						
<b>SG15</b>	C	10	GIS-MOA-LOC-NAD-RCS-FTX			
A group of segments providing information for subsequent use by regulatory authorities requiring statistical and other types of data. It also identifies the regulatory authority for which the information is intended followed by the information itself.						
45	<b>RCS</b>	C	1	Requirements and conditions		
To specify sector/subject requirements and conditions.						
Business Term	DE	EDIFACT	Format	St	*	Description
	7293	Sector area identification code qualifier	an..3	M	*	25 Banking sector
	C550	Requirement/condition identification		A		
	7295	Requirement or condition description identifier	an..17	M		
	1131	Code list identification code	an..17	O		
	3055	Code list responsible agency code	an..3	D		86 Assigned by party originating the message
	7294	Requirement or condition description	an..35	O		
This segment is used to indicate any requirements and conditions related to the transaction which is being reported to the regulatory authorities. Example: Code assigned by the message sender indicating that the requirements and conditions relate to regulatory requirements to report the payment of amount in excess of a certain amount. Example: RCS+25+AB1:23:86:X' Example: RCS+25+AB1::86'						

Max. Occ. = Maximum Occurrence, St = Status, \* = Restricted Codes

Status: M=Mandatory, R=Required, O=Optional, C=Conditional, D=Dependent, A=Advised, N=Not used



## Segment Layout

No. Seg	St	Max. Occ.				
<b>SG4</b>	M	9999	LIN-DTM-RFF-BUS-FCA-SG5-SG6-SG7-SG8-SG9-SG10-SG11			
A group of segments containing information regarding the credit side of the transaction and details which are pertinent to all direct debits specified within the group. Certain payment details may be provided either in segment group 4 or in segment group 11, but not in both.						
<b>SG11</b>	M	99999	SEQ-MOA-DTM-RFF-FCA-SG12-SG13-SG14-SG15-SG16			
This Segment Group contains information regarding the debtor(s) of the direct debit. Certain payment details may be provided either in Segment Group 11 or in Segment Group 4, but not in both.						
<b>SG15</b>	C	10	GIS-MOA-LOC-NAD-RCS-FTX			
A group of segments providing information for subsequent use by regulatory authorities requiring statistical and other types of data. It also identifies the regulatory authority for which the information is intended followed by the information itself.						
46	<b>FTX</b>	C	10	Free text		
To provide free form or coded text information.						
Business Term	DE	EDIFACT	Format	St	*	Description
	4451	Text subject code qualifier	an..3	M	*	REG <b>Regulatory information</b>
	4453	Free text function code	an..3	N		
	C107	Text reference		D		This composite is only used when trading partners have agreed to use mutually defined code values.
	4441	Free text value code	an..17	M		A code identifying standard text agreed between partners.
	1131	Code list identification code	an..17	O		
	3055	Code list responsible agency code	an..3	D		
	C108	Text literal		D		This composite is only used if coded text can not be used.
	4440	Free text value	an..51	M		
	4440	Free text value	an..51	O		
	4440	Free text value	an..51	O		
	4440	Free text value	an..51	O		
	4440	Free text value	an..51	O		
	3453	Language name code	an..3	D		ISO 639 two alpha code. This data element is only used when non coded free text has been provided in data element C108.
This segment is used to provide free or coded text information required by the regulatory authorities. The form and content of this segment is dependent upon the central bank or regulatory authority's requirements.						

Max. Occ. = Maximum Occurrence, St = Status, \* = Restricted Codes

Status: M=Mandatory, R=Required, O=Optional, C=Conditional, D=Dependent, A=Advised, N=Not used

## Segment Layout

---

Use of this segment in free form is not recommended since in most cases it inhibits automatic processing of the direct debit message. Coded references to standard texts is an available functionality which enables automatic processing and reduces transmission and processing overheads. Standard texts should be mutually defined among trading partners and can be used to cover legal and other requirements.

Example:

Example: FTX+REG++1E:23:2+X:X:X:X+AA'

Example: FTX+REG+++SUBJECT TO NATIONAL JURISDICTION'

**Segment Layout**

No. Seg	St	Max. Occ.	
<b>SG4</b>	M	9999	LIN-DTM-RFF-BUS-FCA-SG5-SG6-SG7-SG8-SG9-SG10-SG11
<p>A group of segments containing information regarding the credit side of the transaction and details which are pertinent to all direct debits specified within the group. Certain payment details may be provided either in segment group 4 or in segment group 11, but not in both.</p>			
<b>SG11</b>	M	99999	SEQ-MOA-DTM-RFF-FCA-SG12-SG13-SG14-SG15-SG16
<p>This Segment Group contains information regarding the debtor(s) of the direct debit. Certain payment details may be provided either in Segment Group 11 or in Segment Group 4, but not in both.</p>			
<b>SG16</b>	C	1	PRC-FTX-SG17-SG23
<p>A group of segments containing the details of the direct debit. The content of these segments is passed through the banking chain from the creditor to the debtor.</p>			
47	<b>PRC</b>	M	1 Process identification
<p>To identify a process.</p>			

Business Term	DE	EDIFACT	Format	St	*	Description
	C242	Process type and description		R		
	7187	Process type description code	an..17	M	*	8 Processing of structured information 9 Processing of identical information in structured and unstructured form 10 Processing of different information in structured and unstructured form 11 Processing of unstructured information
	1131	Code list identification code	an..17	O		
	3055	Code list responsible agency code	an..3	O		
	7186	Process type description	an..35	O		
	7186	Process type description	an..35	O		

This segment is used to provide processing information related to an individual direct debit transaction.  
 It should be noted that information sent in groups 16 through 23 is generated by the debtor and is simply forwarded to the creditor via the intermediary bank(s) without amendment.  
 Example:

Max. Occ. = Maximum Occurrence, St = Status, \* = Restricted Codes  
 Status: M=Mandatory, R=Required, O=Optional, C=Conditional, D=Dependent, A=Advised, N=Not used

## Segment Layout

---

Example: PRC+10:23:2:X:X'

Example: PRC+8'

## Segment Layout

No. Seg	St	Max. Occ.				
<b>SG4</b>	M	9999	LIN-DTM-RFF-BUS-FCA-SG5-SG6-SG7-SG8-SG9-SG10-SG11			
A group of segments containing information regarding the credit side of the transaction and details which are pertinent to all direct debits specified within the group. Certain payment details may be provided either in segment group 4 or in segment group 11, but not in both.						
<b>SG11</b>	M	99999	SEQ-MOA-DTM-RFF-FCA-SG12-SG13-SG14-SG15-SG16			
This Segment Group contains information regarding the debtor(s) of the direct debit. Certain payment details may be provided either in Segment Group 11 or in Segment Group 4, but not in both.						
<b>SG16</b>	C	1	PRC-FTX-SG17-SG23			
A group of segments containing the details of the direct debit. The content of these segments is passed through the banking chain from the creditor to the debtor.						
48	<b>FTX</b>	C	5	Free text		
To provide free form or coded text information.						
Business Term	DE	EDIFACT	Format	St	*	Description
	4451	Text subject code qualifier	an..3	M		PMD Payment detail/remittance information
	4453	Free text function code	an..3	N		
	C107	Text reference		D		This composite is only used when trading partners have agreed to use mutually defined code values.
	4441	Free text value code	an..17	M		A code identifying standard text agreed between trading partners.
	1131	Code list identification code	an..17	O		
	3055	Code list responsible agency code	an..3	D		
	C108	Text literal		D		This composite is only used if coded text can not be used.
	4440	Free text value	an..51	M		
	4440	Free text value	an..51	O		
	4440	Free text value	an..51	O		
	4440	Free text value	an..51	O		
	4440	Free text value	an..51	O		
	3453	Language name code	an..3	D		ISO 639 two alpha code. This data element is only used when non coded free text has been provided in data element C108.
This segment is used to provide free or coded text information related to the processing of the direct debit transaction.						

Max. Occ. = Maximum Occurrence, St = Status, \* = Restricted Codes

Status: M=Mandatory, R=Required, O=Optional, C=Conditional, D=Dependent, A=Advised, N=Not used

## Segment Layout

---

Use of this segment in free form is not recommended since in most cases it inhibits automatic processing of the direct debit message. Coded references to standard texts is an available functionality which enables automatic processing and reduces transmission and processing overheads. Standard texts should be mutually defined among trading partners and can be used to cover legal and other requirements.

Example:

Example: FTX+AAG++1E:23:2+BEWARE EMBARGO PAYMENTS:X:X:X:X+EN'

Example: FTX+PMD+++LIMITED LIABILITY+EN'

## Segment Layout

No. Seg	St	Max. Occ.	
<b>SG4</b>	M	9999	LIN-DTM-RFF-BUS-FCA-SG5-SG6-SG7-SG8-SG9-SG10-SG11
A group of segments containing information regarding the credit side of the transaction and details which are pertinent to all direct debits specified within the group. Certain payment details may be provided either in segment group 4 or in segment group 11, but not in both.			
<b>SG11</b>	M	99999	SEQ-MOA-DTM-RFF-FCA-SG12-SG13-SG14-SG15-SG16
This Segment Group contains information regarding the debtor(s) of the direct debit. Certain payment details may be provided either in Segment Group 11 or in Segment Group 4, but not in both.			
<b>SG16</b>	C	1	PRC-FTX-SG17-SG23
A group of segments containing the details of the direct debit. The content of these segments is passed through the banking chain from the creditor to the debtor.			
<b>SG17</b>	C	9999	DOC-MOA-DTM-RFF-NAD-SG18-SG19-SG20
A group of segments providing details of all documents e.g., invoices, statements, despatch advices, etc., to which the direct debit refers. It includes information on the monetary amounts for each document and on any adjustments (with an indication of the reason for adjustments) and discounts.			
49	<b>DOC</b>	M 1	Document/message details
To identify documents and details directly related to it.			

Business Term	DE	EDIFACT	Format	St	*	Description
	C002	Document/message name		M		
	1001	Document name code	an..3	R		82 Metered services invoice 83 Credit note related to financial adjustments 84 Debit note related to financial adjustments 380 Commercial invoice 381 Credit note - goods and services 383 Debit note - goods and services 385 Consolidated invoice 386 Prepayment invoice 389 Self-billed invoice 390 Delcredere invoice
	1131	Code list identification code	an..17	O		
	3055	Code list responsible agency code	an..3	D		
	C503	Document/message details		R		
	1004	Document identifier	an..35	R		
		Document status code				1 Accepted

Max. Occ. = Maximum Occurrence, St = Status, \* = Restricted Codes

Status: M=Mandatory, R=Required, O=Optional, C=Conditional, D=Dependent, A=Advised, N=Not used

**Segment Layout**

Business Term	DE	EDIFACT	Format	St	*	Description
	1373		an..3	O		2 Accompanying goods 4 To arrive by separate EDI message 6 To arrive by manual means
	1366	Document source description	an..70	N		
	3453	Language name code	an..3	O		ISO 639 two alpha code.

This segment is used to provide details of the documents, e.g. a group of invoices, to which an individual direct debit transaction refers.

Example:

Example: `DOC+380:23:2+43534:1::AA'`

Example: `DOC+380+43534'`

Max. Occ. = Maximum Occurrence, St = Status, \* = Restricted Codes

Status: M=Mandatory, R=Required, O=Optional, C=Conditional, D=Dependent, A=Advised, N=Not used



**Segment Layout**

No. Seg	St	Max. Occ.				
<b>SG4</b>	M	9999	LIN-DTM-RFF-BUS-FCA-SG5-SG6-SG7-SG8-SG9-SG10-SG11			
A group of segments containing information regarding the credit side of the transaction and details which are pertinent to all direct debits specified within the group. Certain payment details may be provided either in segment group 4 or in segment group 11, but not in both.						
<b>SG11</b>	M	99999	SEQ-MOA-DTM-RFF-FCA-SG12-SG13-SG14-SG15-SG16			
This Segment Group contains information regarding the debtor(s) of the direct debit. Certain payment details may be provided either in Segment Group 11 or in Segment Group 4, but not in both.						
<b>SG16</b>	C	1	PRC-FTX-SG17-SG23			
A group of segments containing the details of the direct debit. The content of these segments is passed through the banking chain from the creditor to the debtor.						
<b>SG17</b>	C	9999	DOC-MOA-DTM-RFF-NAD-SG18-SG19-SG20			
A group of segments providing details of all documents e.g., invoices, statements, despatch advices, etc., to which the direct debit refers. It includes information on the monetary amounts for each document and on any adjustments (with an indication of the reason for adjustments) and discounts.						
50	<b>MOA</b>	C	5	Monetary amount		
To specify a monetary amount.						
Business Term	DE	EDIFACT	Format	St	*	Description
	C516	Monetary amount		M		
	5025	Monetary amount type code qualifier	an..3	M		9 Amount due/amount payable 11 Amount paid 12 Amount remitted 52 Discount amount 53 Discount amount due 109 Payment discount amount 126 To collect 128 Total amount 139 Total payment amount 143 Transfer amount
	5004	Monetary amount	n..35	R		
This segment is used to specify monetary amounts related to the complete document identified in the previous DOC segment. Example: Example: MOA+9:123' Example: MOA+12:15677'						

Max. Occ. = Maximum Occurrence, St = Status, \* = Restricted Codes  
 Status: M=Mandatory, R=Required, O=Optional, C=Conditional, D=Dependent, A=Advised, N=Not used

## Segment Layout

No. Seg	St	Max. Occ.				
<b>SG4</b>	M	9999	LIN-DTM-RFF-BUS-FCA-SG5-SG6-SG7-SG8-SG9-SG10-SG11			
A group of segments containing information regarding the credit side of the transaction and details which are pertinent to all direct debits specified within the group. Certain payment details may be provided either in segment group 4 or in segment group 11, but not in both.						
<b>SG11</b>	M	99999	SEQ-MOA-DTM-RFF-FCA-SG12-SG13-SG14-SG15-SG16			
This Segment Group contains information regarding the debtor(s) of the direct debit. Certain payment details may be provided either in Segment Group 11 or in Segment Group 4, but not in both.						
<b>SG16</b>	C	1	PRC-FTX-SG17-SG23			
A group of segments containing the details of the direct debit. The content of these segments is passed through the banking chain from the creditor to the debtor.						
<b>SG17</b>	C	9999	DOC-MOA-DTM-RFF-NAD-SG18-SG19-SG20			
A group of segments providing details of all documents e.g., invoices, statements, despatch advices, etc., to which the direct debit refers. It includes information on the monetary amounts for each document and on any adjustments (with an indication of the reason for adjustments) and discounts.						
51	<b>DTM</b>	C	5	Date/time/period		
To specify date, and/or time, or period.						
Business Term	DE	EDIFACT	Format	St	*	Description
	C507	Date/time/period		M		
	2005	Date or time or period function code qualifier	an..3	M	*	137 Document/ message date/ time 138 Payment date 171 Reference date/ time 227 Beneficiary's banks due date 265 Due date
	2380	Date or time or period value	an..35	R		
	2379	Date or time or period format code	an..3	R		102 CCYYMMDD 203 CCYYMMDDHHMM
This segment is used to specify dates related to the document identified in the DOC segment. Example: Example: DTM+137:19970329:102 ' Example: DTM+137:19950510:102 '						

Max. Occ. = Maximum Occurrence, St = Status, \* = Restricted Codes  
Status: M=Mandatory, R=Required, O=Optional, C=Conditional, D=Dependent, A=Advised, N=Not used

## Segment Layout

No. Seg	St	Max. Occ.			
<b>SG4</b>	M	9999	LIN-DTM-RFF-BUS-FCA-SG5-SG6-SG7-SG8-SG9-SG10-SG11		
A group of segments containing information regarding the credit side of the transaction and details which are pertinent to all direct debits specified within the group. Certain payment details may be provided either in segment group 4 or in segment group 11, but not in both.					
<b>SG11</b>	M	99999	SEQ-MOA-DTM-RFF-FCA-SG12-SG13-SG14-SG15-SG16		
This Segment Group contains information regarding the debtor(s) of the direct debit. Certain payment details may be provided either in Segment Group 11 or in Segment Group 4, but not in both.					
<b>SG16</b>	C	1	PRC-FTX-SG17-SG23		
A group of segments containing the details of the direct debit. The content of these segments is passed through the banking chain from the creditor to the debtor.					
<b>SG17</b>	C	9999	DOC-MOA-DTM-RFF-NAD-SG18-SG19-SG20		
A group of segments providing details of all documents e.g., invoices, statements, despatch advices, etc., to which the direct debit refers. It includes information on the monetary amounts for each document and on any adjustments (with an indication of the reason for adjustments) and discounts.					
52	<b>RFF</b>	C	5	Reference	
To specify a reference.					
Business Term	DE	EDIFACT	Format	St	* Description
	C506	Reference		M	
	1153	Reference code qualifier	an..3	M	AAB Proforma invoice number AAJ Delivery order number AAK Despatch advice number CD Credit note number CR Customer reference number CT Contract number DL Debit note number DQ Delivery note number IV Invoice number ON Order number (buyer) PL Price list number POR Purchase order response number PP Purchase order change number VN Order number (supplier)
	1154	Reference identifier	an..70	R	
This segment is used to provide any additional references relevant to the currently identified DOC					

Max. Occ. = Maximum Occurrence, St = Status, \* = Restricted Codes

Status: M=Mandatory, R=Required, O=Optional, C=Conditional, D=Dependent, A=Advised, N=Not used

## Segment Layout

---

segment.

Example:

Example: RFF+ON:74482'

Example: RFF+ON:A-7664'

Max. Occ. = Maximum Occurrence, St = Status, \* = Restricted Codes

Status: M=Mandatory, R=Required, O=Optional, C=Conditional, D=Dependent, A=Advised, N=Not used

## Segment Layout

No. Seg	St	Max. Occ.				
<b>SG4</b>	M	9999	LIN-DTM-RFF-BUS-FCA-SG5-SG6-SG7-SG8-SG9-SG10-SG11			
A group of segments containing information regarding the credit side of the transaction and details which are pertinent to all direct debits specified within the group. Certain payment details may be provided either in segment group 4 or in segment group 11, but not in both.						
<b>SG11</b>	M	99999	SEQ-MOA-DTM-RFF-FCA-SG12-SG13-SG14-SG15-SG16			
This Segment Group contains information regarding the debtor(s) of the direct debit. Certain payment details may be provided either in Segment Group 11 or in Segment Group 4, but not in both.						
<b>SG16</b>	C	1	PRC-FTX-SG17-SG23			
A group of segments containing the details of the direct debit. The content of these segments is passed through the banking chain from the creditor to the debtor.						
<b>SG17</b>	C	9999	DOC-MOA-DTM-RFF-NAD-SG18-SG19-SG20			
A group of segments providing details of all documents e.g., invoices, statements, despatch advices, etc., to which the direct debit refers. It includes information on the monetary amounts for each document and on any adjustments (with an indication of the reason for adjustments) and discounts.						
53	<b>NAD</b>	C	2	Name and address		
To specify the name/address and their related function, either by C082 only and/or unstructured by C058 or structured by C080 thru 3207.						
Business Term	DE	EDIFACT	Format	St	*	Description
	3035	Party function code qualifier	an..3	M		BY Buyer DP Delivery party II Issuer of invoice IV Invoicee SU Supplier UD Ultimate customer
	C082	Party identification details		A		
	3039	Party identifier	an..35	M		
	1131	Code list identification code	an..17	O		
	3055	Code list responsible agency code	an..3	R	*	9 <b>GS1</b>
	C058	Name and address		O		This composite may only be used to fulfill the requirements of directive 2003/58/EC, article 4.
	3124	Name and address description	an..35	M		
	3124	Name and address description	an..35	O		
	3124	Name and address description	an..35	O		
	3124	Name and address description	an..35	O		

Max. Occ. = Maximum Occurrence, St = Status, \* = Restricted Codes

Status: M=Mandatory, R=Required, O=Optional, C=Conditional, D=Dependent, A=Advised, N=Not used

**Segment Layout**

Business Term	DE	EDIFACT	Format	St	*	Description
	3124	Name and address description	an..35	O		
	C080	Party name		D		
	3036	Party name	an..35	M		Party name in clear text.
	3036	Party name	an..35	O		
	3036	Party name	an..35	O		
	3036	Party name	an..35	O		
	3036	Party name	an..35	O		
	3045	Party name format code	an..3	O		
	C059	Street		D		
	3042	Street and number or post office box identifier	an..35	M		Building name/number and street name.
	3042	Street and number or post office box identifier	an..35	O		
	3042	Street and number or post office box identifier	an..35	O		
	3042	Street and number or post office box identifier	an..35	O		
	3164	City name	an..35	D		City/town name, clear text.
	C819	Country sub-entity details		D		
	3229	Country sub-entity name code	an..9	O		
	1131	Code list identification code	an..17	O		
	3055	Code list responsible agency code	an..3	O		
	3228	Country sub-entity name	an..70	O		County/State, clear text.
	3251	Postal identification code	an..17	D		Postal code
	3207	Country name code	an..3	D		ISO 3166 two alpha code

This segment is used to identify any additional parties related to the currently identified document, e.g. delivery party.

Example:

Dependency Notes:

The following composites and data elements are only used when a coded name and address can not be used. The affected composites and data elements are as follows;

C080 - C059 - 3164 - C819 - 3251 - 3207

Example: NAD+AB+X:23:9+X:::X+X:X:X:X:X:1+X:X:X+X+X:23:2:X+X+AD'

Example: NAD+DP+507161511110:::9'

Max. Occ. = Maximum Occurrence, St = Status, \* = Restricted Codes

Status: M=Mandatory, R=Required, O=Optional, C=Conditional, D=Dependent, A=Advised, N=Not used

## Segment Layout

No. Seg	St	Max. Occ.	
<b>SG4</b>	M	9999	LIN-DTM-RFF-BUS-FCA-SG5-SG6-SG7-SG8-SG9-SG10-SG11
A group of segments containing information regarding the credit side of the transaction and details which are pertinent to all direct debits specified within the group. Certain payment details may be provided either in segment group 4 or in segment group 11, but not in both.			
<b>SG11</b>	M	99999	SEQ-MOA-DTM-RFF-FCA-SG12-SG13-SG14-SG15-SG16
This Segment Group contains information regarding the debtor(s) of the direct debit. Certain payment details may be provided either in Segment Group 11 or in Segment Group 4, but not in both.			
<b>SG16</b>	C	1	PRC-FTX-SG17-SG23
A group of segments containing the details of the direct debit. The content of these segments is passed through the banking chain from the creditor to the debtor.			
<b>SG17</b>	C	9999	DOC-MOA-DTM-RFF-NAD-SG18-SG19-SG20
A group of segments providing details of all documents e.g., invoices, statements, despatch advices, etc., to which the direct debit refers. It includes information on the monetary amounts for each document and on any adjustments (with an indication of the reason for adjustments) and discounts.			
<b>SG18</b>	C	5	CUX-DTM
A group of segments specifying the currencies and the related dates/periods valid to the referenced document where different to the reference currency.			
54	<b>CUX</b>	M 1	Currencies
To specify currencies used in the transaction and relevant details for the rate of exchange.			

Business Term	DE	EDIFACT	Format	St	*	Description
	C504	Currency details		R		
	6347	Currency usage code qualifier	an..3	M	*	2 Reference currency
	6345	Currency identification code	an..3	R		ISO 4217 three alpha
	6343	Currency type code qualifier	an..3	R	*	11 Payment currency
	C504	Currency details		D		The second occurrence of this composite is only used if a target currency is being specified.
	6347	Currency usage code qualifier	an..3	M	*	3 Target currency
	6345	Currency identification code	an..3	R		ISO 4217 three alpha
	6343	Currency type code qualifier	an..3	R	*	4 Invoicing currency
	5402	Currency exchange rate	n..12	D		The rate of exchange is only used if a target currency has been identified in the second occurrence of C504.

Max. Occ. = Maximum Occurrence, St = Status, \* = Restricted Codes

Status: M=Mandatory, R=Required, O=Optional, C=Conditional, D=Dependent, A=Advised, N=Not used

## Segment Layout

This segment is used to provide currency rate of exchange information used to convert amounts specified in the MOA segment for the referenced document, to an amount expressed in terms of the remittance/payment currency. This CUX segment will only be used when the currency of its rate of exchange is different from the default global currency or its rate of exchange specified in the CUX segment at heading level.

When specifying the Reference and Target currencies for international trade, one occurrence of CUX is all that is required. The reference currency is identified in the first occurrence of composite C504, with the target currency specified in the second occurrence of C504. The rate of exchange between the two is detailed in DE 5402.

The general rule for calculating the rate of exchange is as follows;

Reference Currency multiplied by Rate = Target Currency.

Example:

Example: CUX+2:EUR:11+3:EUR:4+1020.40'

Example: CUX+2:EUR:11+3:USD:4+0.90243'



## Segment Layout

No. Seg	St	Max. Occ.	
<b>SG4</b>	M	9999	LIN-DTM-RFF-BUS-FCA-SG5-SG6-SG7-SG8-SG9-SG10-SG11 A group of segments containing information regarding the credit side of the transaction and details which are pertinent to all direct debits specified within the group. Certain payment details may be provided either in segment group 4 or in segment group 11, but not in both.
<b>SG11</b>	M	99999	SEQ-MOA-DTM-RFF-FCA-SG12-SG13-SG14-SG15-SG16 This Segment Group contains information regarding the debtor(s) of the direct debit. Certain payment details may be provided either in Segment Group 11 or in Segment Group 4, but not in both.
<b>SG16</b>	C	1	PRC-FTX-SG17-SG23 A group of segments containing the details of the direct debit. The content of these segments is passed through the banking chain from the creditor to the debtor.
<b>SG17</b>	C	9999	DOC-MOA-DTM-RFF-NAD-SG18-SG19-SG20 A group of segments providing details of all documents e.g., invoices, statements, despatch advices, etc., to which the direct debit refers. It includes information on the monetary amounts for each document and on any adjustments (with an indication of the reason for adjustments) and discounts.
<b>SG18</b>	C	5	CUX-DTM A group of segments specifying the currencies and the related dates/periods valid to the referenced document where different to the reference currency.
55 <b>DTM</b>	C	1	Date/time/period To specify date, and/or time, or period.

Business Term	DE	EDIFACT	Format	St	*	Description
	C507	Date/time/period		M		
	2005	Date or time or period function code qualifier	an..3	M	*	134 Rate of exchange date/time 273 Validity period
	2380	Date or time or period value	an..35	R		
	2379	Date or time or period format code	an..3	R		102 CCYYMMDD 718 CCYYMMDD- CCYYMMDD

This segment is used to specify any dates related to the currency information specified in the previous CUX segment.  
Example:  
Example: DTM+134:19970630:102 '  
Example: DTM+134:20020401:102 '

Max. Occ. = Maximum Occurrence, St = Status, \* = Restricted Codes  
Status: M=Mandatory, R=Required, O=Optional, C=Conditional, D=Dependent, A=Advised, N=Not used

**Segment Layout**

No. Seg	St	Max. Occ.	
<b>SG4</b>	M	9999	LIN-DTM-RFF-BUS-FCA-SG5-SG6-SG7-SG8-SG9-SG10-SG11 A group of segments containing information regarding the credit side of the transaction and details which are pertinent to all direct debits specified within the group. Certain payment details may be provided either in segment group 4 or in segment group 11, but not in both.
<b>SG11</b>	M	99999	SEQ-MOA-DTM-RFF-FCA-SG12-SG13-SG14-SG15-SG16 This Segment Group contains information regarding the debtor(s) of the direct debit. Certain payment details may be provided either in Segment Group 11 or in Segment Group 4, but not in both.
<b>SG16</b>	C	1	PRC-FTX-SG17-SG23 A group of segments containing the details of the direct debit. The content of these segments is passed through the banking chain from the creditor to the debtor.
<b>SG17</b>	C	9999	DOC-MOA-DTM-RFF-NAD-SG18-SG19-SG20 A group of segments providing details of all documents e.g., invoices, statements, despatch advices, etc., to which the direct debit refers. It includes information on the monetary amounts for each document and on any adjustments (with an indication of the reason for adjustments) and discounts.
<b>SG19</b>	C	100	AJT-MOA-RFF A group of segments indicating adjustment amounts and their referenced documents.
56	M	1	<b>AJT</b> Adjustment details To identify the reason for an adjustment.

Business Term	DE	EDIFACT	Format	St	*	Description
	4465	Adjustment reason description code	an..3	M		1 Agreed settlement 2 Below specification goods 3 Damaged goods 4 Short delivery 5 Price query 6 Proof of delivery required 9 Invoice error 14 Wrong delivery 17 Transport damage 20 Discount for late delivery 32 Goods not delivered 52 Wrong invoice
	1082	Line item identifier	an..6	N		

This segment is used to indicate the reason for an adjustment to the current document. Adjustments can be given for the whole referenced document identified in the DOC segment and additionally, can also be given per line item in the following DLI segment group.

Example:  
Example: AJT+1 '  
Example: AJT+4 '

Max. Occ. = Maximum Occurrence, St = Status, \* = Restricted Codes  
Status: M=Mandatory, R=Required, O=Optional, C=Conditional, D=Dependent, A=Advised, N=Not used

## Segment Layout

No. Seg	St	Max. Occ.	
<b>SG4</b>	M	9999	LIN-DTM-RFF-BUS-FCA-SG5-SG6-SG7-SG8-SG9-SG10-SG11
A group of segments containing information regarding the credit side of the transaction and details which are pertinent to all direct debits specified within the group. Certain payment details may be provided either in segment group 4 or in segment group 11, but not in both.			
<b>SG11</b>	M	99999	SEQ-MOA-DTM-RFF-FCA-SG12-SG13-SG14-SG15-SG16
This Segment Group contains information regarding the debtor(s) of the direct debit. Certain payment details may be provided either in Segment Group 11 or in Segment Group 4, but not in both.			
<b>SG16</b>	C	1	PRC-FTX-SG17-SG23
A group of segments containing the details of the direct debit. The content of these segments is passed through the banking chain from the creditor to the debtor.			
<b>SG17</b>	C	9999	DOC-MOA-DTM-RFF-NAD-SG18-SG19-SG20
A group of segments providing details of all documents e.g., invoices, statements, despatch advices, etc., to which the direct debit refers. It includes information on the monetary amounts for each document and on any adjustments (with an indication of the reason for adjustments) and discounts.			
<b>SG19</b>	C	100	AJT-MOA-RFF
A group of segments indicating adjustment amounts and their referenced documents.			
57	<b>MOA</b>	M 1	Monetary amount
To specify a monetary amount.			
Business Term	DE	EDIFACT	Format St * Description
	C516	Monetary amount	M
	5025	Monetary amount type code qualifier	an..3 M * 5 Adjusted amount 165 Adjustment amount
	5004	Monetary amount	n..35 R
This segment is used to indicate the value of the adjusted amount for the current document. Adjustment amounts may be given for information purposes only, i.e. not for calculation. The adjustment amount will not necessarily equal the difference between the amount due and the amount remitted. Example: Example: MOA+165:475 ' Example: MOA+5:8700 '			

Max. Occ. = Maximum Occurrence, St = Status, \* = Restricted Codes

Status: M=Mandatory, R=Required, O=Optional, C=Conditional, D=Dependent, A=Advised, N=Not used

## Segment Layout

No. Seg	St	Max. Occ.	
<b>SG4</b>	M	9999	LIN-DTM-RFF-BUS-FCA-SG5-SG6-SG7-SG8-SG9-SG10-SG11
A group of segments containing information regarding the credit side of the transaction and details which are pertinent to all direct debits specified within the group. Certain payment details may be provided either in segment group 4 or in segment group 11, but not in both.			
<b>SG11</b>	M	99999	SEQ-MOA-DTM-RFF-FCA-SG12-SG13-SG14-SG15-SG16
This Segment Group contains information regarding the debtor(s) of the direct debit. Certain payment details may be provided either in Segment Group 11 or in Segment Group 4, but not in both.			
<b>SG16</b>	C	1	PRC-FTX-SG17-SG23
A group of segments containing the details of the direct debit. The content of these segments is passed through the banking chain from the creditor to the debtor.			
<b>SG17</b>	C	9999	DOC-MOA-DTM-RFF-NAD-SG18-SG19-SG20
A group of segments providing details of all documents e.g., invoices, statements, despatch advices, etc., to which the direct debit refers. It includes information on the monetary amounts for each document and on any adjustments (with an indication of the reason for adjustments) and discounts.			
<b>SG19</b>	C	100	AJT-MOA-RFF
A group of segments indicating adjustment amounts and their referenced documents.			
<b>RFF</b>	C	1	Reference
To specify a reference.			

Business Term	DE	EDIFACT	Format	St	*	Description
	C506	Reference		M		
	1153	Reference code qualifier	an..3	M		AAK Despatch advice number ON Order number (buyer) PL Price list number PP Purchase order change number POR Purchase order response number VN Order number (supplier)
	1154	Reference identifier	an..70	R		

This segment is used to specify any references associated with the adjusted amounts. If specific references or information related to a line item number in a document are required then this information is provided in the AJT segment group (group 11) at DLI level.  
Example:  
Example: RFF+PL:NOV199602'  
Example: RFF+PL:JAN-1995'

Max. Occ. = Maximum Occurrence, St = Status, \* = Restricted Codes  
Status: M=Mandatory, R=Required, O=Optional, C=Conditional, D=Dependent, A=Advised, N=Not used

## Segment Layout

No. Seg	St	Max. Occ.				
<b>SG4</b>	M	9999	LIN-DTM-RFF-BUS-FCA-SG5-SG6-SG7-SG8-SG9-SG10-SG11			
A group of segments containing information regarding the credit side of the transaction and details which are pertinent to all direct debits specified within the group. Certain payment details may be provided either in segment group 4 or in segment group 11, but not in both.						
<b>SG11</b>	M	99999	SEQ-MOA-DTM-RFF-FCA-SG12-SG13-SG14-SG15-SG16			
This Segment Group contains information regarding the debtor(s) of the direct debit. Certain payment details may be provided either in Segment Group 11 or in Segment Group 4, but not in both.						
<b>SG16</b>	C	1	PRC-FTX-SG17-SG23			
A group of segments containing the details of the direct debit. The content of these segments is passed through the banking chain from the creditor to the debtor.						
<b>SG17</b>	C	9999	DOC-MOA-DTM-RFF-NAD-SG18-SG19-SG20			
A group of segments providing details of all documents e.g., invoices, statements, despatch advices, etc., to which the direct debit refers. It includes information on the monetary amounts for each document and on any adjustments (with an indication of the reason for adjustments) and discounts.						
<b>SG20</b>	C	1000	DLI-MOA-PIA-SG22			
A group of segments which may be used when required to provide details of individual line items in the reference document.						
59	<b>DLI</b>	M 1	Document line identification			
To specify the processing mode of a specific line within a referenced document.						
Business Term	DE	EDIFACT	Format	St	*	Description
	1073	Document line action code	an..3	M		1 Included in document/transaction 2 Excluded from document/transaction
	1082	Line item identifier	an..6	M		
This segment is used to identify individual line items within the document identified in the DOC segment. Example: Example: DLI+1+7' Example: DLI+2+55'						

Max. Occ. = Maximum Occurrence, St = Status, \* = Restricted Codes

Status: M=Mandatory, R=Required, O=Optional, C=Conditional, D=Dependent, A=Advised, N=Not used

**Segment Layout**

No. Seg	St	Max. Occ.	
<b>SG4</b>	M	9999	LIN-DTM-RFF-BUS-FCA-SG5-SG6-SG7-SG8-SG9-SG10-SG11
A group of segments containing information regarding the credit side of the transaction and details which are pertinent to all direct debits specified within the group. Certain payment details may be provided either in segment group 4 or in segment group 11, but not in both.			
<b>SG11</b>	M	99999	SEQ-MOA-DTM-RFF-FCA-SG12-SG13-SG14-SG15-SG16
This Segment Group contains information regarding the debtor(s) of the direct debit. Certain payment details may be provided either in Segment Group 11 or in Segment Group 4, but not in both.			
<b>SG16</b>	C	1	PRC-FTX-SG17-SG23
A group of segments containing the details of the direct debit. The content of these segments is passed through the banking chain from the creditor to the debtor.			
<b>SG17</b>	C	9999	DOC-MOA-DTM-RFF-NAD-SG18-SG19-SG20
A group of segments providing details of all documents e.g., invoices, statements, despatch advices, etc., to which the direct debit refers. It includes information on the monetary amounts for each document and on any adjustments (with an indication of the reason for adjustments) and discounts.			
<b>SG20</b>	C	1000	DLI-MOA-PIA-SG22
A group of segments which may be used when required to provide details of individual line items in the reference document.			
60	<b>MOA</b>	M 5	Monetary amount To specify a monetary amount.

Business Term	DE	EDIFACT	Format	St	*	Description
	C516	Monetary amount		M		
	5025	Monetary amount type code qualifier	an..3	M		9 Amount due/amount payable 12 Amount remitted 52 Discount amount 53 Discount amount due 109 Payment discount amount 143 Transfer amount 203 Line item amount
	5004	Monetary amount	n..35	R		
	6345	Currency identification code	an..3	O		

This segment is used to indicate the amount due and the amount remitted for the line item identified in the DLI segment for the current document.  
Example:  
Example: MOA+203:500:ARS '  
Example: MOA+12:4500 '  
Example: MOA+9:52000 '

Max. Occ. = Maximum Occurrence, St = Status, \* = Restricted Codes  
Status: M=Mandatory, R=Required, O=Optional, C=Conditional, D=Dependent, A=Advised, N=Not used

## Segment Layout

No. Seg	St	Max. Occ.				
<b>SG4</b>	M	9999	LIN-DTM-RFF-BUS-FCA-SG5-SG6-SG7-SG8-SG9-SG10-SG11			
A group of segments containing information regarding the credit side of the transaction and details which are pertinent to all direct debits specified within the group. Certain payment details may be provided either in segment group 4 or in segment group 11, but not in both.						
<b>SG11</b>	M	99999	SEQ-MOA-DTM-RFF-FCA-SG12-SG13-SG14-SG15-SG16			
This Segment Group contains information regarding the debtor(s) of the direct debit. Certain payment details may be provided either in Segment Group 11 or in Segment Group 4, but not in both.						
<b>SG16</b>	C	1	PRC-FTX-SG17-SG23			
A group of segments containing the details of the direct debit. The content of these segments is passed through the banking chain from the creditor to the debtor.						
<b>SG17</b>	C	9999	DOC-MOA-DTM-RFF-NAD-SG18-SG19-SG20			
A group of segments providing details of all documents e.g., invoices, statements, despatch advices, etc., to which the direct debit refers. It includes information on the monetary amounts for each document and on any adjustments (with an indication of the reason for adjustments) and discounts.						
<b>SG20</b>	C	1000	DLI-MOA-PIA-SG22			
A group of segments which may be used when required to provide details of individual line items in the reference document.						
61	<b>PIA</b>	C 5	Additional product id			
To specify additional or substitutional item identification codes.						
Business Term	DE	EDIFACT	Format	St	*	Description
	4347	Product identifier code qualifier	an..3	M	*	5 Product identification
	C212	Item number identification		M		
	7140	Item identifier	an..35	R		
	7143	Item type identification code	an..3	R		AC HIBC (Health Industry Bar Code) IB ISBN (International Standard Book Number) IN Buyer's item number SA Supplier's article number SRV GS1 Global Trade Item Number
	1131	Code list identification code	an..17	O		
	3055	Code list responsible agency code	an..3	D		9 GS1 91 Assigned by supplier or supplier's agent 92 Assigned by buyer

Max. Occ. = Maximum Occurrence, St = Status, \* = Restricted Codes

Status: M=Mandatory, R=Required, O=Optional, C=Conditional, D=Dependent, A=Advised, N=Not used

**Segment Layout**

Business Term	DE	EDIFACT	Format	St	*	Description
						or buyer's agent
	C212	Item number identification		O		
	7140	Item identifier	an..35	R		
	7143	Item type identification code	an..3	R		
	1131	Code list identification code	an..17	O		
	3055	Code list responsible agency code	an..3	D		
	C212	Item number identification		O		
	7140	Item identifier	an..35	R		
	7143	Item type identification code	an..3	R		
	1131	Code list identification code	an..17	O		
	3055	Code list responsible agency code	an..3	D		
	C212	Item number identification		O		
	7140	Item identifier	an..35	R		
	7143	Item type identification code	an..3	R		
	1131	Code list identification code	an..17	O		
	3055	Code list responsible agency code	an..3	D		
	C212	Item number identification		O		
	7140	Item identifier	an..35	R		
	7143	Item type identification code	an..3	R		
	1131	Code list identification code	an..17	O		
	3055	Code list responsible agency code	an..3	D		

This segment is used to provide the product identification of the line item detailed in the DLI segment for the current document.

Example:

Example: PIA+5+X:AA:23:2+X:AA:23:2+X:AA:23:2+X:AA:23:2+X:AA:23:2'

Example: PIA+5+3323456007803:SRV'

Max. Occ. = Maximum Occurrence, St = Status, \* = Restricted Codes

Status: M=Mandatory, R=Required, O=Optional, C=Conditional, D=Dependent, A=Advised, N=Not used



**Segment Layout**

No. Seg	St	Max. Occ.	
<b>SG4</b>	M	9999	LIN-DTM-RFF-BUS-FCA-SG5-SG6-SG7-SG8-SG9-SG10-SG11 A group of segments containing information regarding the credit side of the transaction and details which are pertinent to all direct debits specified within the group. Certain payment details may be provided either in segment group 4 or in segment group 11, but not in both.
<b>SG11</b>	M	99999	SEQ-MOA-DTM-RFF-FCA-SG12-SG13-SG14-SG15-SG16 This Segment Group contains information regarding the debtor(s) of the direct debit. Certain payment details may be provided either in Segment Group 11 or in Segment Group 4, but not in both.
<b>SG16</b>	C	1	PRC-FTX-SG17-SG23 A group of segments containing the details of the direct debit. The content of these segments is passed through the banking chain from the creditor to the debtor.
<b>SG17</b>	C	9999	DOC-MOA-DTM-RFF-NAD-SG18-SG19-SG20 A group of segments providing details of all documents e.g., invoices, statements, despatch advices, etc., to which the direct debit refers. It includes information on the monetary amounts for each document and on any adjustments (with an indication of the reason for adjustments) and discounts.
<b>SG20</b>	C	1000	DLI-MOA-PIA-SG22 A group of segments which may be used when required to provide details of individual line items in the reference document.
<b>SG22</b>	C	10	AJT-MOA-RFF A group of segments indicating adjustment amounts and their reference documents.
62	<b>AJT</b>	M 1	Adjustment details To identify the reason for an adjustment.

Business Term	DE	EDIFACT	Format	St	*	Description
	4465	Adjustment reason description code	an..3	M		1 Agreed settlement 2 Below specification goods 3 Damaged goods 4 Short delivery 5 Price query 6 Proof of delivery required 9 Invoice error 14 Wrong delivery 17 Transport damage 20 Discount for late delivery 32 Goods not delivered

This segment is used to indicate the reason for an adjustment to the current line identified in the DLI segment.  
 Example:  
 Example: AJT+5'

Max. Occ. = Maximum Occurrence, St = Status, \* = Restricted Codes  
 Status: M=Mandatory, R=Required, O=Optional, C=Conditional, D=Dependent, A=Advised, N=Not used

## Segment Layout

---

Example: AJT+5'

## Segment Layout

No. Seg	St	Max. Occ.				
<b>SG4</b>	M	9999	LIN-DTM-RFF-BUS-FCA-SG5-SG6-SG7-SG8-SG9-SG10-SG11			
A group of segments containing information regarding the credit side of the transaction and details which are pertinent to all direct debits specified within the group. Certain payment details may be provided either in segment group 4 or in segment group 11, but not in both.						
<b>SG11</b>	M	99999	SEQ-MOA-DTM-RFF-FCA-SG12-SG13-SG14-SG15-SG16			
This Segment Group contains information regarding the debtor(s) of the direct debit. Certain payment details may be provided either in Segment Group 11 or in Segment Group 4, but not in both.						
<b>SG16</b>	C	1	PRC-FTX-SG17-SG23			
A group of segments containing the details of the direct debit. The content of these segments is passed through the banking chain from the creditor to the debtor.						
<b>SG17</b>	C	9999	DOC-MOA-DTM-RFF-NAD-SG18-SG19-SG20			
A group of segments providing details of all documents e.g., invoices, statements, despatch advices, etc., to which the direct debit refers. It includes information on the monetary amounts for each document and on any adjustments (with an indication of the reason for adjustments) and discounts.						
<b>SG20</b>	C	1000	DLI-MOA-PIA-SG22			
A group of segments which may be used when required to provide details of individual line items in the reference document.						
<b>SG22</b>	C	10	AJT-MOA-RFF			
A group of segments indicating adjustment amounts and their reference documents.						
63	<b>MOA</b>	M 1	Monetary amount			
To specify a monetary amount.						
Business Term	DE	EDIFACT	Format	St	*	Description
	C516	Monetary amount		M		
	5025	Monetary amount type code qualifier	an..3	M	*	5 Adjusted amount 165 Adjustment amount
	5004	Monetary amount	n..35	R		
<p>This segment is used to indicate the value of the adjusted amount for the current line item. Adjustment amounts may be provided for information purposes only, e.g. not for calculation. The adjustment amount will not necessarily equal the difference between the amount due and the amount remitted.</p> <p>The adjustment amount will always be expressed in terms of the remittance/payment currency.</p> <p>Example:</p> <p>Example: MOA+5:605'</p> <p>Example: MOA+5:4920'</p>						

Max. Occ. = Maximum Occurrence, St = Status, \* = Restricted Codes  
 Status: M=Mandatory, R=Required, O=Optional, C=Conditional, D=Dependent, A=Advised, N=Not used

## Segment Layout

No. Seg	St	Max. Occ.				
<b>SG4</b>	M	9999	LIN-DTM-RFF-BUS-FCA-SG5-SG6-SG7-SG8-SG9-SG10-SG11			
A group of segments containing information regarding the credit side of the transaction and details which are pertinent to all direct debits specified within the group. Certain payment details may be provided either in segment group 4 or in segment group 11, but not in both.						
<b>SG11</b>	M	99999	SEQ-MOA-DTM-RFF-FCA-SG12-SG13-SG14-SG15-SG16			
This Segment Group contains information regarding the debtor(s) of the direct debit. Certain payment details may be provided either in Segment Group 11 or in Segment Group 4, but not in both.						
<b>SG16</b>	C	1	PRC-FTX-SG17-SG23			
A group of segments containing the details of the direct debit. The content of these segments is passed through the banking chain from the creditor to the debtor.						
<b>SG17</b>	C	9999	DOC-MOA-DTM-RFF-NAD-SG18-SG19-SG20			
A group of segments providing details of all documents e.g., invoices, statements, despatch advices, etc., to which the direct debit refers. It includes information on the monetary amounts for each document and on any adjustments (with an indication of the reason for adjustments) and discounts.						
<b>SG20</b>	C	1000	DLI-MOA-PIA-SG22			
A group of segments which may be used when required to provide details of individual line items in the reference document.						
<b>SG22</b>	C	10	AJT-MOA-RFF			
A group of segments indicating adjustment amounts and their reference documents.						
64	<b>RFF</b>	C 1	Reference			
To specify a reference.						
Business Term	DE	EDIFACT	Format	St	*	Description
	C506	Reference		M		
	1153	Reference code qualifier	an..3	M		ON Order number (buyer) PL Price list number PP Purchase order change number POR Purchase order response number VN Order number (supplier)
	1154	Reference identifier	an..70	R		
	1156	Document line identifier	an..6	O		
This segment is used to specify any references associated with the adjustment amounts for the current line item. Example: Example: RFF+CT:61894870:X'						

Max. Occ. = Maximum Occurrence, St = Status, \* = Restricted Codes

Status: M=Mandatory, R=Required, O=Optional, C=Conditional, D=Dependent, A=Advised, N=Not used

## Segment Layout

---

Example: RFF+PP:6522'
-----------------------

## Segment Layout

No. Seg	St	Max. Occ.	
<b>SG4</b>	M	9999	LIN-DTM-RFF-BUS-FCA-SG5-SG6-SG7-SG8-SG9-SG10-SG11
<p>A group of segments containing information regarding the credit side of the transaction and details which are pertinent to all direct debits specified within the group. Certain payment details may be provided either in segment group 4 or in segment group 11, but not in both.</p>			
<b>SG11</b>	M	99999	SEQ-MOA-DTM-RFF-FCA-SG12-SG13-SG14-SG15-SG16
<p>This Segment Group contains information regarding the debtor(s) of the direct debit. Certain payment details may be provided either in Segment Group 11 or in Segment Group 4, but not in both.</p>			
<b>SG16</b>	C	1	PRC-FTX-SG17-SG23
<p>A group of segments containing the details of the direct debit. The content of these segments is passed through the banking chain from the creditor to the debtor.</p>			
<b>SG23</b>	C	1	GIS-MOA
<p>A group of segments indicating the end of the details of payment and specifying hash total amounts for control purposes.</p>			
65	<b>GIS</b>	M 1	General indicator
<p>To transmit a processing indicator.</p>			
<p>Notes: 1. This segment will be removed effective with directory D.02B.</p>			
Business Term	DE	EDIFACT	Format St * Description
	C529	Processing indicator	M
	7365	Processing indicator description code	an..3 M * 37 Complete information
<p>This segment is used to indicate the end of the detail of payment. It is recommended that this segment always be included in order to explicitly indicate the end of the payment details. Example: Example: GIS+37 ' Example: GIS+37 '</p>			

Max. Occ. = Maximum Occurrence, St = Status, \* = Restricted Codes  
Status: M=Mandatory, R=Required, O=Optional, C=Conditional, D=Dependent, A=Advised, N=Not used

## Segment Layout

No. Seg	St	Max. Occ.	
<b>SG4</b>	M	9999	LIN-DTM-RFF-BUS-FCA-SG5-SG6-SG7-SG8-SG9-SG10-SG11 A group of segments containing information regarding the credit side of the transaction and details which are pertinent to all direct debits specified within the group. Certain payment details may be provided either in segment group 4 or in segment group 11, but not in both.
<b>SG11</b>	M	99999	SEQ-MOA-DTM-RFF-FCA-SG12-SG13-SG14-SG15-SG16 This Segment Group contains information regarding the debtor(s) of the direct debit. Certain payment details may be provided either in Segment Group 11 or in Segment Group 4, but not in both.
<b>SG16</b>	C	1	PRC-FTX-SG17-SG23 A group of segments containing the details of the direct debit. The content of these segments is passed through the banking chain from the creditor to the debtor.
<b>SG23</b>	C	1	GIS-MOA A group of segments indicating the end of the details of payment and specifying hash total amounts for control purposes.
66	<b>MOA</b>	C 5	Monetary amount To specify a monetary amount.

Business Term	DE	EDIFACT	Format	St	*	Description
	C516	Monetary amount		M		
	5025	Monetary amount type code qualifier	an..3	M		128 Total amount
	5004	Monetary amount	n..35	R		

This segment is used to indicate the total value of level C for control purposes. The figure detailed here is simply an accumulation of the values specified in all MOA segments in level C regardless of the qualifiers used in DE 5025.  
Example:  
Example: MOA+203:500'  
Example: MOA+128:25601'

Max. Occ. = Maximum Occurrence, St = Status, \* = Restricted Codes  
Status: M=Mandatory, R=Required, O=Optional, C=Conditional, D=Dependent, A=Advised, N=Not used

**Segment Layout**

No. Seg	St	Max. Occ.				
67	<b>CNT</b>	C 5	Control total To provide control total.			
Business Term	DE	EDIFACT	Format	St	*	Description
	C270	Control		M		
	6069	Control total type code qualifier	an..3	M		2 Number of line items in message 40 Total number of sequence details in message
	6066	Control total value	n..18	M		
	6411	Measurement unit code	an..3	O		
<p>This segment is used to provide application data for message control purposes.            Example:            Example: CNT+1:9:H87'            Example: CNT+2:26'</p>						

Max. Occ. = Maximum Occurrence, St = Status, \* = Restricted Codes

Status: M=Mandatory, R=Required, O=Optional, C=Conditional, D=Dependent, A=Advised, N=Not used



**Segment Layout**

No. Seg	St	Max. Occ.				
<b>SG24</b>	C	5	AUT-DTM			
A group of segments specifying details of any authentication (validation) procedures applied to the DIRDEB message.						
68	<b>AUT</b>	M	1	Authentication result		
To specify results of the application of an authentication procedure.						
Business Term	DE	EDIFACT	Format	St	*	Description
	9280	Validation result value	an..35	M		
	9282	Validation key identifier	an..35	O		
<p>This segment is used to provide details of any authentication procedures which have been applied to the direct debit message. The use of this segment is, including any algorithms and calculation procedures, dependent on bilaterally agreed conditions between the message sender and receiver.</p> <p>Example:</p> <p>Example: AUT+X+X'</p> <p>Example: AUT+7761'</p>						

Max. Occ. = Maximum Occurrence, St = Status, \* = Restricted Codes

Status: M=Mandatory, R=Required, O=Optional, C=Conditional, D=Dependent, A=Advised, N=Not used

**Segment Layout**

No. Seg	St	Max. Occ.				
<b>SG24</b>	C	5	AUT-DTM			
A group of segments specifying details of any authentication (validation) procedures applied to the DIRDEB message.						
69	<b>DTM</b>	C	1	Date/time/period		
To specify date, and/or time, or period.						
Business Term	DE	EDIFACT	Format	St	*	Description
	C507	Date/time/period		M		
	2005	Date or time or period function code qualifier	an..3	M	*	218 Authentication/validation date/time
	2380	Date or time or period value	an..35	R		
	2379	Date or time or period format code	an..3	R		102 CCYYMMDD 203 CCYYMMDDHHMM
This segment is used to provide details related to the date and where necessary, the time, of the direct debit message validation. Example: The direct debit message was validated at 12 noon on the 1st of June 2002.  Example: DTM+218:X:2' Example: DTM+218:200206011200:203'						

Max. Occ. = Maximum Occurrence, St = Status, \* = Restricted Codes

Status: M=Mandatory, R=Required, O=Optional, C=Conditional, D=Dependent, A=Advised, N=Not used

**Segment Layout**

No. Seg	St	Max. Occ.			
70	<b>UNT</b>	M 1	Message trailer To end and check the completeness of a message.		
Business Term	DE	EDIFACT	Format	St	* Description
	0074	Number of segments in the message	n..6	M	The total number of segments in the message.
	0062	Message reference number	an..14	M	The message reference numbered detailed here should equal the one specified in the UNH segment.
<p>The UNT segment is a mandatory UN/EDIFACT segment. It must always be the last segment in the message.            Example:            Example: UNT+68+X'            Example: UNT+68+00025'</p>					

Max. Occ. = Maximum Occurrence, St = Status, \* = Restricted Codes

Status: M=Mandatory, R=Required, O=Optional, C=Conditional, D=Dependent, A=Advised, N=Not used

**Segment Layout**

No. Seg	St	Max. Occ.				
71	<b>UNZ</b>	M 1	Interchange trailer To end and check the completeness of an interchange.			
Business Term	DE	EDIFACT	Format	St	*	Description
	0036	Interchange control count	n..6	M		Number of messages or functional groups within an interchange.
	0020	Interchange control reference	an..14	M		Identical to DE 0020 in UNB segment.
<p>This segment is used to provide the trailer of an interchange.  DE 0036: If functional groups are used, this is the number of functional groups within the interchange. If functional groups are not used, this is the number of messages within the interchange.</p> <p>Example: UNZ+1+12345555 '  Example: UNZ+5+12345555 '</p>						

Max. Occ. = Maximum Occurrence, St = Status, \* = Restricted Codes

Status: M=Mandatory, R=Required, O=Optional, C=Conditional, D=Dependent, A=Advised, N=Not used

## Used Codes

---

<b>0001</b>	<p>Syntax identifier Coded identification of the agency controlling a syntax and syntax level used in an interchange.</p> <p>Notes: 1. a3, upper case, Controlling Agency (e.g. UNO=UN/ECE) and a1 stating level (e.g. A) (which together give UNOA).</p>
UNOA	<p>UN/ECE level A As defined in the basic code table of ISO 646 with the exceptions of lower case letters, alternative graphic character allocations and national or application-oriented graphic character allocations.</p>
UNOB	<p>UN/ECE level B As defined in the basic code table of ISO 646 with the exceptions of alternative graphic character allocations and national or application-oriented graphic character allocations.</p>
UNOC	<p>UN/ECE level C As defined in ISO/IEC 8859-1 : Information technology - Part 1: Latin alphabet No. 1.</p>
UNOD	<p>UN/ECE level D As defined in ISO/IEC 8859-2 : Information technology - Part 2: Latin alphabet No. 2.</p>
UNOE	<p>UN/ECE level E As defined in ISO/IEC 8859-5 : Information technology - Part 5: Latin/Cyrillic alphabet.</p>
UNOF	<p>UN/ECE level F As defined in ISO 8859-7 : Information processing - Part 7: Latin/Greek alphabet.</p>
<b>0002</b>	<p>Syntax version number Version number of the syntax identified in the syntax identifier (0001)</p> <p>Notes: 1. Increments 1 for each version.</p>
3	<p>Version 3 ISO 9735 Amendment 1:1992. GS1 Description: Syntax version number 3. This code can be used with all of the character sets (A, B, C, D, E and F).</p>

## Used Codes

---

<b>0007</b>	Partner identification code qualifier Qualifier referring to the source of codes for the identifiers of interchanging partners.
	Notes: 1. Used with sender/recipient identification code.
14	GS1 Partner identification code assigned by GS1, an international organization of GS1 Member Organizations that manages the GS1 System.
<b>0025</b>	Recipient's reference/password qualifier Qualifier for the recipient's reference or password.
	Notes: 1. If specified in IA.
AA	Reference Recipient's reference/password is a reference.
BB	Password Recipient's reference/password is a password.
<b>0029</b>	Processing priority code Code determined by the sender requesting processing priority for the interchange.
	Notes: 1. Used if specified in IA.
A	Highest priority Requested processing priority is the highest.
<b>0031</b>	Acknowledgement request Code determined by the sender for acknowledgement of the interchange.
	Notes: 1. Set = 1 if sender requests acknowledgement, i.e. UNB and UNZ segments received and identified.
1	Requested Acknowledgement is requested.
<b>0035</b>	Test indicator Indication that the interchange is a test.
	Notes: 1. Set = 1 if the interchange is a test. Otherwise not used.

## Used Codes

---

1	Interchange is a test Indicates that the interchange is a test.
5	Interchange is a service provider test Indicates that this interchange is a test with a service provider.
<b>0051</b>	Controlling agency Code to identify the agency controlling the specification, maintenance and publication of the message type.
UN	UN/CEFACT United Nations Centre for Trade Facilitation and Electronic Business (UN/CEFACT). GS1 Description: UN Economic Commission for Europe (UN/ECE), Committee on the development of trade (TRADE), Working Party on facilitation of international trade procedures (WP.4).
<b>0052</b>	Message version number Version number of a message type.  Notes: 1. If UNG/UNE is used, shall be identical in UNG and UNE. The representation of 0052 was specified as n..3 in version 1 of ISO 9735.
D	Draft version/UN/EDIFACT Directory Message approved and issued as a draft message (Valid for directories published after March 1993 and prior to March 1997). Message approved as a standard message (Valid for directories published after March 1997).
<b>0054</b>	Message release number Release number within the current message type version number (0052).  Notes: 1. The representation of 0054 was specified as n..3 in version 1 of ISO 9735.
01B	Release 2001 - B Message approved and issued in the second 2001 release of the UNTDID (United Nations Trade Data Interchange Directory).
<b>0057</b>	Association assigned code A code assigned by the association responsible for the design and maintenance of the message type concerned, which further identifies the message.
EAN003	GS1 version control number (GS1 Permanent Code) Indicates that the message is an EANCOM message in version 003.

## Used Codes

---

<b>0065</b>	<p>Message type Code identifying a type of message and assigned by its controlling agency.</p> <p>Notes: 1. Type of message being transmitted.</p>
DIRDEB	<p>Direct debit message A code to identify the direct debit message. GS1 Description: Message sent by the creditor to the creditor's bank instructing it to claim specified amounts from the debtor(s) and to credit these amounts to a single account it services for the creditor in settlement of the referenced transaction(s).</p>
<b>1001</b>	<p>Document name code Code specifying the document name.</p>
1	<p>Certificate of analysis Certificate providing the values of an analysis.</p>
2	<p>Certificate of conformity Certificate certifying the conformity to predefined definitions.</p>
3	<p>Certificate of quality Certificate certifying the quality of goods, services etc.</p>
4	<p>Test report Report providing the results of a test session.</p>
9	<p>Price/sales catalogue A document/message to enable the transmission of information regarding pricing and catalogue details for goods and services offered by a seller to a buyer.</p>
10	<p>Party information Document/message providing basic data concerning a party.</p>
35	<p>Inventory report A message specifying information relating to held inventories.</p>
44	<p>Transport status report A message to report the transport status and/or change in the transport status (i.e. event) between agreed parties.</p>
46	<p>Banking status A banking status document and/or message.</p>
51	<p>Price/sales catalogue response A document providing a response to a previously sent price/sales catalogue.</p>
54	<p>Legal statement of an account A statement of an account containing the booked items as in the ledger of the account servicing financial institution.</p>



**Used Codes**

55	Listing statement of an account A statement from the account servicing financial institution containing items pending to be booked.
56	Closing statement of an account Last statement of a period containing the interest calculation and the final balance of the last entry date.
67	Commercial dispute Document/message issued by a party (usually the buyer) to indicate that one or more invoices or one or more credit notes are disputed for payment.
77	Consignment status report Message covers information about the consignment status.
78	Inventory movement advice Advice of inventory movements.
82	Metered services invoice Document/message claiming payment for the supply of metered services (e.g., gas, electricity, etc.) supplied to a fixed meter whose consumption is measured over a period of time.
83	Credit note related to financial adjustments Document message for providing credit information related to financial adjustments to the relevant party, e.g., bonuses.
84	Debit note related to financial adjustments Document/message for providing debit information related to financial adjustments to the relevant party.
105	Purchase order Document/message issued within an enterprise to initiate the purchase of articles, materials or services required for the production or manufacture of goods to be offered for sale or otherwise supplied to customers.
130	Invoicing data sheet Document/message issued within an enterprise containing data about goods sold, to be used as the basis for the preparation of an invoice.
141	Advising items to be booked to a financial account A document and/or message advising of items which have to be booked to a financial account.
172	Authorisation to plan and suggest orders Document or message that authorises receiver to plan orders, based on information in this message, and send these orders as suggestions to the sender.
173	Authorisation to plan and ship orders Document or message that authorises receiver to plan and ship orders based on information in this message.

## Used Codes

---

174	Drawing The document or message is a drawing. GS1 Description: A message used for the administration of the exchange of external objects.
182	Balance confirmation Confirmation of a balance at an entry date.
213	Request for financial cancellation The message is a request for financial cancellation.
214	Pre-authorized direct debit(s) The message contains pre-authorized direct debit(s).
220	Order Document/message by means of which a buyer initiates a transaction with a seller involving the supply of goods or services as specified, according to conditions set out in an offer, or otherwise known to the buyer.
221	Blanket order Usage of document/message for general order purposes with later split into quantities and delivery dates and maybe delivery locations.
223	Lease order Document/message for goods in leasing contracts.
224	Rush order Document/message for urgent ordering.
225	Repair order Document/message to order repair of goods.
226	Call off order Document/message to provide split quantities and delivery dates referring to a previous blanket order.
227	Consignment order Order to deliver goods into stock with agreement on payment when goods are sold out of this stock.
230	Purchase order change request Change to an purchase order already sent.
231	Purchase order response Response to an purchase order already received.
236	Delivery forecast A message which enables the transmission of delivery or product forecasting requirements.

**Used Codes**

237	<p>Cross docking services order</p> <p>A document or message to order cross docking services.</p> <p>GS1 Description: An order requesting cross docking services for goods to be delivered to a retailer.</p>
238	<p>Non-pre-authorized direct debit(s)</p> <p>The message contains non-pre-authorized direct debit(s).</p>
240	<p>Delivery instructions</p> <p>Document/message issued by a buyer giving instructions regarding the details of the delivery of goods ordered.</p> <p>GS1 Description: A message from a party to another party who has control over ordered goods, providing instructions to despatch a consignment according to conditions specified in the message.</p>
241	<p>Delivery schedule</p> <p>Usage of DELFOR-message.</p> <p>GS1 Description: A message which enables the transmission of delivery scheduling or product forecasting requirements.</p>
243	<p>Pre-authorized direct debit request(s)</p> <p>The message contains pre-authorized direct debit request(s).</p>
244	<p>Non-pre-authorized direct debit request(s)</p> <p>The message contains non-pre-authorized direct debit request(s).</p>
251	<p>Inquiry</p> <p>This is a request for information.</p> <p>GS1 Description: A message enabling the sender to inquire on a product or a group of products from a master product catalogue or file according to criteria defined in the message.</p>
252	<p>Response to previous banking status message</p> <p>A response to a previously sent banking status message.</p>
258	<p>Standing order</p> <p>An order to supply fixed quantities of products at fixed regular intervals.</p>
261	<p>Self billed credit note</p> <p>A document which indicates that the customer is claiming credit in a self billing environment.</p>
262	<p>Consolidated credit note - goods and services</p> <p>Credit note for goods and services that covers multiple transactions involving more than one invoice.</p>
263	<p>Inventory adjustment status report</p> <p>A message detailing statuses related to the adjustment of inventory.</p>

## Used Codes

---

270	<p>Delivery note</p> <p>Paper document attached to a consignment informing the receiving party about contents of this consignment.</p>
289	<p>Product data message</p> <p>A message to submit master data, a set of data that is rarely changed, to identify and describe products a supplier offers to their (potential) customer or buyer.</p> <p>GS1 Description: A message between parties containing master data, to identify and describe products available for supply or for information purposes. This information of long validity does not include commercial terms and conditions but technical and functional product descriptions.</p>
291	<p>Delivery schedule response</p> <p>A message providing a response to a previously transmitted delivery schedule.</p>
297	<p>Instruction to collect</p> <p>A message instructing a party to collect goods.</p>
305	<p>Application error and acknowledgement</p> <p>A message to inform a message issuer that a previously sent message has been received by the addressee's application, or that a previously sent message has been rejected by the addressee's application.</p>
308	<p>Delcredere credit note</p> <p>A credit note sent to the party paying on behalf of a number of buyers.</p>
310	<p>Offer/quotation</p> <p>Document/message which , with a view to concluding a contract, sets out the conditions under which the goods are offered.</p>
311	<p>Request for quote</p> <p>Document/message requesting a quote on specified goods or services.</p>
315	<p>Contract</p> <p>Document/message evidencing an agreement between the seller and the buyer for the supply of goods or services; its effects are equivalent to those of an order followed by an acknowledgement of order.</p>
325	<p>Proforma invoice</p> <p>Document/message serving as a preliminary invoice, containing - on the whole - the same information as the final invoice, but not actually claiming payment.</p>
335	<p>Booking request</p> <p>Document/message issued by a supplier to a carrier requesting space to be reserved for a specified consignment, indicating desirable conveyance, despatch time, etc.</p>
338	<p>Items booked to a financial account report</p> <p>A message reporting items which have been booked to a financial account.</p>

## Used Codes

---

340	Shipping instructions Document/message advising details of cargo and exporter's requirements for its physical movement.
341	Shipper's letter of instructions (air) Document/message issued by a consignor in which he gives details of a consignment of goods that enables an airline or its agent to prepare an air waybill.
342	Report of transactions for information only A message reporting transactions for information only.
345	Ready for despatch advice Document/message issued by a supplier informing a buyer that goods ordered are ready for despatch.
347	Order status enquiry A message enquiring the status of previously sent orders.
348	Order status report A message reporting the status of previously sent orders.
350	Despatch order Document/message issued by a supplier initiating the despatch of goods to a buyer (consignee).
351	Despatch advice Document/message by means of which the seller or consignor informs the consignee about the despatch of goods.
376	Standing inquiry on product information A product inquiry which stands until it is cancelled. GS1 Description: An initial download and any future changes made to the data within the standing request is automatically sent to the buyer as they occur, until the standing request is cancelled.  Notes: A standing product inquiry implies that the supplier will send both a one-time download and notification of all future changes to the requested trade item until the standing request is deleted. A standing product inquiry can only be modified by deleting the original request and initiating a new request.
380	Commercial invoice Document/message claiming payment for goods or services supplied under conditions agreed between seller and buyer.
381	Credit note - goods and services Document/message for providing credit information to the relevant party.
382	Commission note Document/message in which a seller specifies the amount of commission, the percentage of the invoice amount, or some other basis for the calculation of the commission to which a sales agent is entitled.

## Used Codes

---

383	Debit note - goods and services Document/message for providing debit information to the relevant party.
384	Corrected invoice Commercial invoice that includes revised information differing from an earlier submission of the same invoice.
385	Consolidated invoice Commercial invoice that covers multiple transactions involving more than one vendor. GS1 Description: Commercial invoice that covers multiple transactions involving more than one delivery.
386	Prepayment invoice An invoice to pay amounts for goods and services in advance; these amounts will be subtracted from the final invoice.
388	Tax invoice An invoice for tax purposes.
389	Self-billed invoice An invoice the invoicee is producing instead of the seller.
390	Delcredere invoice An invoice sent to the party paying for a number of buyers.
393	Factored invoice Invoice assigned to a third party for collection.
397	Commercial account summary response A document providing a response to a previously sent commercial account summary message.
400	Exceptional order An order which falls outside the framework of an agreement. GS1 Description: An order which falls outside the framework of an agreement or an order containing non-standard information.
401	Transshipment order An order requesting the supply of products packed according to the final delivery point which will be moved across a dock in a distribution centre without further handling.
402	Cross docking order An order requesting the supply of products which will be de-consolidated in the distribution centre and re-consolidated according to final delivery location.
447	Collection order Document/message whereby a bank is instructed (or requested) to handle financial and/or commercial documents in order to obtain acceptance and/or payment, or to deliver documents on such other terms and conditions as may be specified.

## Used Codes

---

452	<p>Multiple payment order</p> <p>Document/message containing a payment order to debit one or more accounts and to credit one or more beneficiaries.</p>
481	<p>Remittance advice</p> <p>Document/message advising of the remittance of payment.</p>
493	<p>Statement of account message</p> <p>Usage of STATAC-message.</p>
527	<p>Self billed debit note</p> <p>A document which indicates that the customer is claiming debit in a self billing environment.</p>
610	<p>Forwarding instructions</p> <p>Document/message issued to a freight forwarder, giving instructions regarding the action to be taken by the forwarder for the forwarding of goods described therein.</p>
630	<p>Shipping note</p> <p>Document/message provided by the shipper or his agent to the carrier, multimodal transport operator, terminal or other receiving authority, giving information about export consignments offered for transport, and providing for the necessary receipts and declarations of liability. (Sometimes a multipurpose cargo handling document also fulfilling the functions of document 632, 633, 650 and 655).</p> <p>GS1 Description:</p> <p>Document/message provided by the shipper or his agent to the carrier, multimodal transport operator, terminal or other receiving authority, giving information about export consignments offered for transport, and providing for the necessary receipts and declarations of liability.</p>
632	<p>Goods receipt</p> <p>Document/message to acknowledge the receipt of goods and in addition may indicate receiving conditions.</p> <p>GS1 Description:</p> <p>Message addressing the business needs related to the goods receipt or advising discrepancies between despatched or ordered/planned goods.</p>
700	<p>Waybill</p> <p>Non-negotiable document evidencing the contract for the transport of cargo.</p>
701	<p>Universal (multipurpose) transport document</p> <p>Document/message evidencing a contract of carriage covering the movement of goods by any mode of transport, or combination of modes, for national as well as international transport, under any applicable international convention or national law and under the conditions of carriage of any carrier or transport operator undertaking or arranging the transport referred to in the document.</p>

## Used Codes

---

705	<p>Bill of lading</p> <p>Negotiable document/message which evidences a contract of carriage by sea and the taking over or loading of goods by carrier, and by which carrier undertakes to deliver goods against surrender of the document. A provision in the document that goods are to be delivered to the order of a named person, or to order, or to bearer, constitutes such an undertaking.</p>
706	<p>Bill of lading original</p> <p>The original of the bill of lading issued by a transport company. When issued by the maritime industry it could signify ownership of the cargo.</p>
707	<p>Bill of lading copy</p> <p>A copy of the bill of lading issued by a transport company.</p>
719	<p>General message</p> <p>Document/message providing agreed textual information. GS1 Note: Replaces GS1 Temporary Code 14E.</p>
720	<p>Rail consignment note (generic term)</p> <p>Transport document constituting a contract for the carriage of goods between the sender and the carrier (the railway). For international rail traffic, this document must conform to the model prescribed by the international conventions concerning carriage of goods by rail, e.g. CIM Convention, SMGS Convention.</p>
721	<p>Product data response</p> <p>Document/message responding to a previously received Product Data document/message. GS1 Note: Replaces GS1 Temporary Code 1E.</p>
725	<p>Manufacturer raised order</p> <p>Document/message providing details of an order which has been raised by a manufacturer. GS1 Note: Replaces GS1 Temporary Code 22E.</p>
726	<p>Manufacturer raised consignment order</p> <p>Document/message providing details of a consignment order which has been raised by a manufacturer. GS1 Note: Replaces GS1 Temporary Code 23E.</p>
727	<p>Price/sales catalogue not containing commercial information</p> <p>A price/sales catalogue message containing no commercial such as prices, terms or conditions data. GS1 Note: Replaces GS1 Temporary Code 24E.</p>
728	<p>Price/sales catalogue containing commercial information</p> <p>A price/sales catalogue message including commercial such as prices, terms or conditions data. GS1 Note: Replaces GS1 Temporary Code 25E.</p>
729	<p>Returns advice</p> <p>Document/message by means of which the buyer informs the seller about the despatch of returned goods. GS1 Note: Replaces GS1 Temporary Code 35E.</p>



## Used Codes

---

730	<p>Road consignment note</p> <p>Transport document/message which evidences a contract between a carrier and a sender for the carriage of goods by road (generic term). Remark: For international road traffic, this document must contain at least the particulars prescribed by the convention on the contract for the international carriage of goods by road (CMR).</p>
731	<p>Commercial account summary</p> <p>A message enabling the transmission of commercial data concerning payments made and outstanding items on an account over a period of time. GS1 Note: Replaces GS1 Temporary Code 49E.</p>
732	<p>Announcement for returns</p> <p>A message by which a party announces to another party details of goods for return due to specified reasons (e.g. returns for repair, returns because of damage, etc). GS1 Note: Replaces GS1 Temporary Code 70E.</p>
733	<p>Instruction for returns</p> <p>A message by which a party informs another party whether and how goods shall be returned. GS1 Note: Replaces GS1 Temporary Code 71E.</p>
734	<p>Sales forecast report</p> <p>A message enabling companies to exchange or report electronically, basic sales forecast data related to products or services, including the corresponding location, time period, product identification, pricing and quantity information. It enables the recip. GS1 Note: Replaces GS1 Temporary Code 72E.</p>
735	<p>Sales data report</p> <p>A message enabling companies to exchange or report electronically, basic sales data related to products or services, including the corresponding location, time period, product identification, pricing and quantity information. It enables the recipient to process the information automatically and use it for production, marketing or statistical purposes. GS1 Note: Replaces GS1 Temporary Code 73E.</p>
736	<p>Standing inquiry on complete product information</p> <p>A product inquiry which stands until it is cancelled. It requests not only the updates since last time, but always the complete product information of a data supplier. This means that within the standing request every time a complete download of the respective data is automatically sent to the data inquirer.</p>
737	<p>Proof of delivery</p> <p>A message by which a consignee provides for a carrier proof of delivery of a consignment.</p>
738	<p>Cargo/goods handling and movement message</p> <p>A message from a party to a warehouse, distribution centre, or logistics service provider identifying the handling services and where required the movement of specified goods, limited to warehouses within the jurisdiction of the distribution centre or logistics service provider. GS1 Note: Replaces GS1 Temporary Code 90E.</p>

## Used Codes

---

739	<p>Metered services consumption report supporting an invoice Document/message providing metered consumption details supporting an invoice. GS1 Note: Replaces GS1 Temporary Code 94E.</p>
740	<p>Air waybill Document/message made out by or on behalf of the shipper which evidences the contract between the shipper and carrier(s) for carriage of goods over routes of the carrier(s) and which is identified by the airline prefix issuing the document plus a serial (IATA).</p>
742	<p>Metered services consumption report Document/message providing metered consumption details. GS1 Note: Replaces GS1 Temporary Code 99E.</p>
747	<p>Payroll deductions advice A message sent by a party (usually an employer or its representative) to a service providing organisation, to detail payroll deductions paid on behalf of its employees to the service providing organisation. GS1 Note: Replaces GS1 Temporary Code YA3.</p>
748	<p>Consignment despatch advice Document/message by means of which the supplier informs the buyer about the despatch of goods ordered on consignment (goods to be delivered into stock with agreement on payment when goods are sold out of this stock). GS1 Note: Replaces GS1 Temporary Code YA7.</p>
763	<p>Forwarder's certificate of transport Negotiable document/message issued by a forwarder to certify that he has taken charge of a specified consignment for despatch and delivery in accordance with the consignor's instructions, as indicated in the document, and that he accepts responsibility for delivery of the goods to the holder of the document through the intermediary of a delivery agent of his choice. E.g. FIATA-FCT.</p>
770	<p>Booking confirmation Document/message issued by a carrier to confirm that space has been reserved for a consignment in means of transport.</p>
781	<p>Arrival notice (goods) Notification from the carrier to the consignee in writing, by telephone or by any other means (express letter, message, telegram, etc.) informing him that a consignment addressed to him is being or will shortly be held at his disposal at a specified point in the place of destination.</p>
811	<p>Export licence Permit issued by a government authority permitting exportation of a specified commodity subject to specified conditions as quantity, country of destination, etc. Synonym: Embargo permit.</p>
821	<p>Despatch note model T1 Transit declaration for goods circulating under internal community transit procedures (between European Union (EU) countries).</p>

## Used Codes

---

822	Despatch note model T2 Ascertainment that the declared goods were originally produced in an European Union (EU) country.
830	Goods declaration for exportation Document/message by which goods are declared for export Customs clearance, conforming to the layout key set out at Appendix I to Annex C.1 concerning outright exportation to the Kyoto convention (CCC). Within a Customs union, "for despatch" may have the same meaning as "for exportation".
852	Sanitary certificate Document/message issued by the competent authority in the exporting country evidencing that alimentary and animal products, including dead animals, are fit for human consumption, and giving details, when relevant, of controls undertaken.
861	Certificate of origin Document/message identifying goods, in which the authority or body authorized to issue it certifies expressly that the goods to which the certificate relates originate in a specific country. The word "country" may include a group of countries, a region or a part of a country. This certificate may also include a declaration by the manufacturer, producer, supplier, exporter or other competent person.
890	Dangerous goods declaration Document/message issued by a consignor in accordance with applicable conventions or regulations, describing hazardous goods or materials for transport purposes, and stating that the latter have been packed and labelled in accordance with the provisions of the relevant conventions or regulations.
898	Pre-packed cross docking consignment order A consignment order requesting the supply of products packed according to the final delivery point which will be moved across a dock in a distribution centre without further handling. GS1 Note: replaces YD1 (GS1 Temporary code)
910	Import licence, application for Document/message in which an interested party applies to the competent body for authorization to import either a limited quantity of articles subject to import restrictions, or an unlimited quantity of such articles during a limited period, and specifies the kind of articles, their origin and value, etc.
911	Import licence Document/message issued by the competent body in accordance with import regulations in force, by which authorization is granted to a named party to import either a limited quantity of designated articles or an unlimited quantity of such articles during a limited period, under conditions specified in the document.
938	Tax declaration (general) Document/message containing a general tax declaration.

## Used Codes

---

951	<p>TIF forms</p> <p>International Customs transit document by which the sender declares goods for carriage by rail in accordance with the provisions of the 1952 International Convention to facilitate the crossing of frontiers for goods carried by rail (TIF Convention of UIC).</p>
952	<p>TIR Carnet</p> <p>International Customs document (International Transit by Road), issued by a guaranteeing association approved by the Customs authorities, under the cover of which goods are carried, in most cases under Customs seal, in road vehicles and/or containers in compliance with the requirements of the Customs TIR Convention of the International Transport of Goods under cover of TIR Carnets (UN/ECE).</p>
954	<p>EUR 1 certificate of origin</p> <p>Undefined Section</p> <p>Customs certificate used in preferential goods interchanges between EC countries and EC external countries.</p>
991	<p>Government contract</p> <p>Document/message describing a contract with a government authority.</p>
14E	<p>General message (GS1 Temporary Code)</p> <p>Document/message providing agreed textual information.</p> <p>GS1 Note: Code marked for deletion. Use value 719 instead.</p>
1E	<p>Product data response (GS1 Temporary Code)</p> <p>A message responding to a previously received Product Data message.</p> <p>GS1 Note: Code marked for deletion. Use value 721 instead.</p>
22B	<p>Order for retained approval copies (GS1 Temporary Code)</p> <p>Description to be provided.</p> <p>GS1 Note: Code marked for deletion.</p>
22E	<p>Manufacturer raised order (GS1 Temporary Code)</p> <p>Document/message providing details of an order which has been raised by a manufacturer.</p> <p>GS1 Note: Code marked for deletion. Use value 725 instead.</p>
23E	<p>Manufacturer raised consignment order (GS1 Temporary Code)</p> <p>Document/message providing details of a consignment order which has been raised by a manufacturer.</p> <p>GS1 Note: Code marked for deletion. Use value 726 instead.</p>
24E	<p>Price/sales catalogue not containing pricing information (GS1 Temporary Code)</p> <p>A price/sales catalogue message containing no commercial terms or conditions data.</p> <p>GS1 Note: Code marked for deletion. Use value 727 instead.</p>
25E	<p>Price/sales catalogue containing pricing information (GS1 Temporary Code)</p> <p>A price/sales catalogue message containing only commercial terms or conditions data.</p> <p>GS1 Note: Code marked for deletion. Use value 728 instead.</p>

## Used Codes

---

26E	<p>Consignment issue (GS1 Permanent Code)</p> <p>Document/message providing details of a consignment issue which has been raised by a buyer.</p>
27E	<p>Release Order (GS1 Permanent Code)</p> <p>Document/message providing ability for buyer to send out a "Release Order" according to a blanket order previously sent through.</p>
2E	<p>Data distribution profile (GS1 Temporary Code)</p> <p>Message containing instructions on the distribution of data stored in a database.</p>
31B	<p>Quote used for bookseller's new title notices (GS1 Temporary Code)</p> <p>A quotation raised by a bookseller as a way of informing prospective buyers of new titles.</p>
35E	<p>Returns advice (GS1 Temporary Code)</p> <p>Document/message by means of which the buyer informs the seller about the despatch or impending despatch of returned goods. GS1 Note: Code marked for deletion. Use value 729 instead.</p>
49E	<p>Commercial account summary (GS1 Temporary Code)</p> <p>A message enabling the transmission of commercial data concerning payments made and outstanding items on an account over a period of time. GS1 Note: Code marked for deletion. Use value 731 instead.</p>
70E	<p>Announcement for returns (GS1 Temporary Code)</p> <p>A message by which a party announces to another party details of goods for return due to specified reasons (e.g. returns for repair, returns because of damage, etc). GS1 Note: Code marked for deletion. Use value 732 instead.</p>
71E	<p>Instruction for returns (GS1 Temporary Code)</p> <p>A message by which a party informs another party whether and how goods shall be returned. GS1 Note: Code marked for deletion. Use value 733 instead.</p>
72E	<p>Sales forecast report (GS1 Temporary Code)</p> <p>A message enabling companies to exchange or report electronically, basic sales forecast data related to products or services, including the corresponding location, time period, product identification, pricing and quantity information. It enables the recipient to process the information automatically and use it for production, planning, marketing or statistical purposes. GS1 Note: Code marked for deletion. Use value 734 instead.</p>
73E	<p>Sales data report (GS1 Temporary Code)</p> <p>A message enabling companies to exchange or report electronically, basic sales data related to products or services, including the corresponding location, time period, product identification, pricing and quantity information. It enables the recipient to process the information automatically and use it for production, marketing or statistical purposes. GS1 Note: Code marked for deletion. Use value 735 instead.</p>

## Used Codes

---

76C	<p>Standing inquiry on complete product information (GS1 Temporary Code)</p> <p>A product inquiry which stands until it is cancelled. It requests not only the updates since last time, but always the complete product information of a data supplier. This means that within the standing request every time a complete download of the respective data is automatically sent to the datainquirer.</p> <p>GS1 Note: Code marked for deletion. Use value 736 instead.</p>
78E	<p>Proof of delivery (GS1 Temporary Code)</p> <p>A message by which a consignee provides for a carrier proof of delivery of a consignment.</p> <p>GS1 Note: Code marked for deletion. Use value 737 instead.</p>
90E	<p>Cargo/goods handling and movement message (GS1 Temporary Code)</p> <p>A message from a party to a warehouse, distribution centre, or logistics service provider identifying the handling services and where required the movement of specified goods, limited to warehouses within the jurisdiction of the distribution centre or logistics service provider.</p> <p>GS1 Note: Code marked for deletion. Use value 738 instead.</p>
94E	<p>Metered services consumption report invoice support (GS1 Temporary Code)</p> <p>A Metered Services Consumption Report is a communication between trading parties, or their agents, providing consumption and where required associated technical information at a location(s) for a product(s) or service(s) where the supply is recorded using a meter(s) to support information contained in commercial invoices.</p> <p>GS1 Note: Code marked for deletion. Use value 739 instead.</p>
99E	<p>Metered services consumption report (GS1 Temporary Code)</p> <p>A Metered Services Consumption Report is a communication between trading parties, or their agents, providing consumption and where required associated technical information at a location(s) for a product(s) or service(s) where the supply is recorded using a meter(s).</p> <p>GS1 Note: Code marked for deletion. Use value 742 instead.</p>
YA3	<p>Payroll deductions advice (GS1 Temporary Code)</p> <p>A message sent by a party (usually an employer or its representative) to a service providing organisation, to detail payroll deductions paid on behalf of its employees to the service providing organisation.</p> <p>GS1 Note: Code marked for deletion. Use value 747 instead.</p>
YA5	<p>Intermediate handling cross docking despatch advice (GS1 Temporary Code)</p> <p>Document by means of which the supplier or consignor informs the buyer, consignee or the distribution centre about the despatch of goods needing intermediate handling.</p>
YA6	<p>Pre-packed cross docking [transshipment] despatch advice (GS1 Temporary Code)</p> <p>Document by means of which the supplier or consignor informs the buyer, consignee or distribution centre about the despatch of pre-packed goods.</p>

**Used Codes**

YA7	Consignment despatch advice (GS1 Temporary Code) Document/message by means of which the supplier informs the buyer about the despatch of goods ordered on consignment (goods to be delivered into stock with agreement on payment when goods are sold out of this stock). GS1 Note: Code marked for deletion. Use value 748 instead.
YB3	Ready for transshipment despatch advice (GS1 Temporary Code) Document/message by means of which the supplier or consignor informs the buyer, consignee or the distribution center that the goods ordered are ready for transshipment.
YB4	Media campaign document (GS1 Temporary Code) Document providing the details of a media campaign
YB5	Product Marketing document, detailed (GS1 Temporary Code) Marketing document providing a detailed functional description of a product or goods/services.
YB6	Product Marketing document, concise (GS1 Temporary Code) Marketing document providing a concise functional description of a product or goods/services.
YB7	Self billed debit note correction (GS1 Temporary Code) Debit note message that includes revised information differing from an earlier submission of the same debit note in a self billing environment.
YB8	Debit note correction (GS1 Temporary Code) Debit note message that includes revised information differing from an earlier submission of the same debit note.
YC1	Consumer pickup order (GS1 Permanent Code) Consumer order with pickup at store.
YC2	Consumer home delivery order (GS1 Permanent Code) Consumer order with home delivery.
YC3	Consumer pickup delivery note (GS1 Permanent Code) Despatch advice for a consumer order with pickup at store.
YC4	Consumer home delivery note (GS1 Permanent Code) Despatch advice for a consumer order with home delivery.
YD1	Pre-packed cross docking consignment order (GS1 Temporary Code) A consignment order requesting the supply of products packed according to the final delivery point which will be moved across a dock in a distribution centre without further handling. GS1 Note: Code marked for deletion. Use value 898 instead.
<b>1073</b>	Document line action code Code indicating an action associated with a line of a document.
1	Included in document/transaction The document line is included in the document/transaction.

## Used Codes

---

2	Excluded from document/transaction The document line is excluded from the document/transaction.
<b>1131</b>	Code list identification code Code identifying a user or association maintained code list.  Notes: 1. The codes for this data element are provided by the code list responsible agency defined in data element 3055.
23	Clearing house automated payment Self explanatory.  Notes: This code value will be removed effective with directory D.04A. GS1 Description: Banking community' automated payment clearing system.
25	Bank identification Code for identification of banks.  Notes: This code value will be removed effective with directory D.04A.
106	Incoterms 1980 (4110) Code to indicate applicable Incoterm (1980 edition) under which seller undertakes to deliver merchandise to buyer (ICC). Incoterms 1990: use 4053 only.  Notes: This code value will be removed effective with directory D.04A.
132	Charge Identification of a type of charge.  Notes: This code value will be removed effective with directory D.04A.
154	Bank branch sorting identification Identification of a specific branch of a bank.  Notes: This code value will be removed effective with directory D.04A.
157	Clearing code Identification of the responsible bank/clearing house which has cleared or is ordered to do the clearing.  Notes: This code value will be removed effective with directory D.04A.



## Used Codes

---

166	<p>Social security identification Code assigned by the authority competent to issue social security identification to identify a person.</p> <p>Notes: This code value will be removed effective with directory D.04A.</p>
174	<p>Citizen identification Self explanatory.</p> <p>Notes: This code value will be removed effective with directory D.04A.</p> <p>GS1 Description: Code issued by national authority competent to issue citizen identification to identify a person.</p>
1E	<p>Incoterms 1990 (GS1 Temporary Code) Incoterms 1990 as published by the International Chamber of Commerce (ICC).</p>
2E	<p>Incoterms 2000 (GS1 Temporary Code) Incoterms 2000 as published by the International Chamber of Commerce (ICC).</p>
3E	<p>Incoterms 2010 (GS1 Temporary Code) Incoterms 2010 as published by the International Chamber of Commerce (ICC).</p>
ADR	<p>Accord European au transport international dangereuses (GS1 Temporary Code) A European agreement concerning the international carriage of dangerous goods by road.</p>
BR	<p>Brand (GS1 Temporary Code) An identifying mark or label on the products of a particular company, or the kind or make of a commodity.</p>
CA	<p>Category (GS1 Temporary Code) A class or division in a scheme of classification.</p>
CO	<p>Colour (GS1 Temporary Code) Description of the colour required/available on the goods.</p>
FL	<p>Flavor (GS1 Temporary Code) The characteristic quality of goods.</p>
HMT	<p>Hazardous material standard text (GS1 Temporary Code) Code indicating agreed standard text on hazardous materials.</p>
LOC	<p>Location Code (GS1 Temporary Code) This is a code to indicate where the EAS tag is located on the Trade Item. Values include On outside of Trade Item, Concealed inside Trade Item, Integrated Inside Trade Item.</p>

## Used Codes

OAG	Organic Claim Agency (GS1 Temporary Code) A governing body that creates and maintain standards related to organic products.
OCO	Organic Trade Item Code (GS1 Temporary Code) Used to indicate the organic status of a trade item or of one or more of its components.
OUM	Ordering unit of measure (GS1 Temporary Code) The alternate Unit of Measure of how Trade Items are ordered by the Retailer under one Unit of Measure, but sold under another Unit of Measure.
SKB	SKRS recommendation (GS1 Temporary Code) SKRS recommendation for standard clothes hanger.
SRN	Service relation number (GS1 Temporary Code) A number used to identify a database entry which records recurring services, e.g., treatment of a patient in a hospital, usage by a member of a library facilities, etc.
ST	Style (GS1 Temporary Code) Specific or characteristic design in any goods.
SUM	Selling unit of measure (GS1 Temporary Code) Describes the measurement used for selling unit of the Trade Item to the end consumer.
SZ	Size (GS1 Temporary Code) Any of a series of graded classifications of measure into which goods are divided.
SZG	Size Group (GS1 Temporary Code) A description of the variable size that is necessary to uniquely specify the size of the item in conjunction with the nonpackaged size dimension.
TYP	Type Code (GS1 Temporary Code) This is a code to indicate the type of EAS tag located on the Trade Item. Values include Acousto-Magnetic, Electro-Magnetic, Ink or dye, Microwave, Radio Frequency.
X11	Diet Allergen (GS1 Temporary Code) Indication of which dietary or allergen marks that are on the package.
X12	Environment (GS1 Temporary Code) Indication of which environmental marks (e.g. recycling schemes) that are on trade item package.
X13	Ethical (GS1 Temporary Code) Indication of which ethical trading marks that are on the package.
X14	Free Form (GS1 Temporary Code) Indication of which free-from marks that are on the package.

## Used Codes

---

X15	Expiration date (GS1 Temporary Code) Indicates the type of expiration date marked on the packaging.
X16	Nesting Direction (GS1 Temporary Code) Depicts the arrangement of two items that nest together specifically whether they nest against each other or on top of each other.
X17	Package Marks Hygienic (GS1 Temporary Code) Indication of which hygiene markings are present in the product package
X18	Hazardous Components are Removable (GS1 Temporary Code) An indicator if any hazardous components contained within the trade item can easily be separated from the other materials to facilitate product recycling.
X19	Trade Item Has Refuse Obligations (GS1 Temporary Code) Indicates if there are special disposal obligations that apply to the trade item for example INTRASTAT.
X20	Trade Item Is Designed for Easy Disassembly (GS1 Temporary Code) Indicates that the trade item is designed for easy disassembly by recycling facilities using standard industry tools.
X21	Trade Item Is Rigid Plastic Packaging Container (GS1 Temporary Code) Indicates that a product is or is contained in a Rigid Plastic Packaging Container (RPPC) as defined by laws in the target market.
X22	Trade Item Is ROHS Compliant (GS1 Temporary Code) Indicates if the product is compliant with the European Union RoHS Directive.
X23	Trade Item Is Universal Waste (GS1 Temporary Code) Indicates if a product can be considered universal waste.
X24	Trade Item Is Consumer Upgradeable Or Maintainable (GS1 Temporary Code) Indicates if a product can be easily upgraded or have parts replaced by the consumer.
X25	Trade Item Contains Short Chain Chlorinated Paraffins (GS1 Temporary Code) Indicate if the trade item and/or its components contain paints, coatings, plastics or other materials containing short chain chlorinated paraffins (SCCPs).
X26	Trade Item Contains Pesticide (GS1 Temporary Code) Indicates if the trade item is advertised or labelled as a chemical or contains a chemical that is advertised or labelled to kill, repel or prevent the growth of any living organism.
X27	Trade Item Contains Propellant (GS1 Temporary Code) Indicates if a trade item contains a compressed gas or propellant.
X28	Trade Item Contains Polyvinyl Chloride (GS1 Temporary Code) Indicate if product contains Polyvinyl Chloride (PVC), a widely used thermoplastic polymer.

## Used Codes

---

X29	Trade Item Chemical Is Not Intended For Human Consumption (GS1 Temporary Code) Indicates that the trade item is or contains a Liquid, Gel, Paste, Powder, or Flammable solid not intended for human consumption (ingested).
X30	ROHS Compliance Failure Material (GS1 Temporary Code) The material used in the trade item that does not comply with the ROHS Directives
X31	Packaging Terms And Condition (GS1 Temporary Code) Indicates if the packaging given in the described packaging configuration is a rented, exchangeable, against deposit or one way/not reusable.
X32	Warranty Effective Date Type (GS1 Temporary Code) The type of date associated with the warranty trade item usually expressed as an event date for the item for example date of purchase, date of manufacture or date of delivery.
X33	Warranty Type (GS1 Temporary Code) Type of warranty available for the part, e.g. labour, distance, extended service.
X35	Warranty Constraint (GS1 Temporary Code) Defines the relationship between different guarantee terms, e.g. "and", "or", "the stronger", "the weaker".
X36	Seasonal Availability End Date (GS1 Temporary Code) Indicates the end date of the trade item's seasonal availability.
X37	Seasonal Availability Start Date (GS1 Temporary Code) Indicates the start date of the trade item's seasonal availability.
X38	Season Calendar Year (GS1 Temporary Code) This element indicates the calendar year in which the trade item is seasonally available.
X39	Season Parameter (GS1 Temporary Code) Indication of the season, in which the trade item is available.
X40	Trade Item Automatic Power Down is Enabled (GS1 Temporary Code) An indicator whether a product is enabled with auto power down feature when shipped to the customer.
X41	Electrical Usage Agency Code (GS1 Temporary Code) The agency that regulates electrical usage for products within a target market.
X42	Nesting Type (GS1 Temporary Code) Depicts whether a nested item fits inside or over the other item in a nesting relationship.
X43	Display Dimension Type Code (GS1 Temporary Code) Depicts certain display scenarios used for measurement.

## Used Codes

---

X44	<p>Manufacturer Has Take Back Program (GS1 Temporary Code)</p> <p>Indicates if the manufacturer of the trade item offers any take back programs to consumers for the product to be reused, remanufactured or recycled by the manufacturer.</p>
X45	<p>Display Resolution (GS1 Temporary Code)</p> <p>The display resolution of a television or computer display.</p>
X46	<p>Orientation Preference Sequence (GS1 Temporary Code)</p> <p>Depicts the preferred sequence of orientation used to communicate the manufacturers relative preferences of orientation.</p>
X47	<p>Orientation Type (GS1 Temporary Code)</p> <p>Depicts via code a display orientation for a trade item.</p>
X48	<p>Electrical Usage Trade Item Classification Code (GS1 Temporary Code)</p> <p>A classification code value from a product classification scheme provided to drive required information for electrical usage.</p>
X49	<p>Electrical Usage Trade Item Classification Name (GS1 Temporary Code)</p> <p>A classification name from a product classification scheme provided to drive required information for electrical usage.</p>
X50	<p>Electrical Usage SubClassification Code (GS1 Temporary Code)</p> <p>A sub-classification code value from a product classification scheme provided to drive required information for electrical usage.</p>
X51	<p>Electrical Usage SubClassification Name (GS1 Temporary Code)</p> <p>A sub-classification name provided to drive required information for electrical usage.</p>
X52	<p>Confirmation Status Code (GS1 Temporary Code)</p> <p>The CIC Confirmation Code must be of a type of code number that can be generated automatically by a computer system.</p>
X53	<p>Confirmation Status Code Description (GS1 Temporary Code)</p> <p>Provides the code description that matches up with the Code that can possibly be generated automatically by a computer system.</p>
X54	<p>Additional Confirmation Status Description (GS1 Temporary Code)</p> <p>Provides a way to communicate human entered information that may not be covered by the machine to machine codes and descriptions.</p>
X55	<p>Corrective Action (GS1 Temporary Code)</p> <p>Provides the corrective action code to fix the issue that caused the problem.</p>
X56	<p>Expected Corrective Information (GS1 Temporary Code)</p> <p>Provides the expected corrective information via a human entered information that may not be covered by the machine to machine codes.</p>
X57	<p>Electrical Usage Trade Item Classification Agency (GS1 Temporary Code)</p> <p>A classification agency or organisation whose product classification scheme is being provided to drive required information for electrical usage.</p>

**Used Codes**

X58	ASFIS (GS1 Permanent Code) FAO alphah-3 code list for fish species identification, commercial name & scientific name.
X59	FAO fishing areas (GS1 Permanent Code) FAO fishing areas codelist.
X60	FAO Fishing gear type (GS1 Permanent Code) FAO Fishing gear type codelist.
X61	EU fish quality (GS1 Permanent Code) EU fish quality grade code list (E, A, B, C).
X62	EU fish size (GS1 Permanent Code) EU fish standardized size code list (1, 2, 3, 4, 5 & One_Size).
X63	EU fish presentation (GS1 Permanent Code) EU fish presentation code list (3 or 5 char alpha code).
ZZZ	Mutually defined Self explanatory. Note : This code value will be removed effective with directory D.04A.
<b>1153</b>	Reference code qualifier Code qualifying a reference.
AAB	Proforma invoice number [1088] Reference number assigned by the seller to a Proforma Invoice.
AAC	Documentary credit number [1172] Reference number assigned by issuing bank to a Documentary credit.
AAF	Debit card number A reference number identifying a debit card.
AAG	Offer or quotation number Reference number assigned by issuing party to an offer.
AAJ	Delivery order number Reference number assigned by issuer to a delivery order.
AAK	Despatch advice number Reference number assigned by issuing party to a despatch advice.
AAL	Drawing number Reference number identifying a specific product drawing.
AAM	Waybill number Reference number assigned to a waybill, see: 1001 = 700.
AAN	Delivery schedule number Reference number assigned by buyer to a delivery schedule.

## Used Codes

---

AAO	Consignee's shipment reference number [1362] Reference assigned by the consignee to a shipment.
AAQ	Unit load device (e.g. container) identification number [8260] Marks (letters and/or numbers) which identify a unit load device e.g. freight container.
AAS	Transport document number [1188] Reference assigned by the carrier or his agent to the transport document.
AAT	Master label number Identifies the master label number of any package type.
AAU	Despatch note number [1128] Reference number assigned by the seller to a Despatch Note.
ABD	Customs tariff number (7357) Code number of the goods in accordance with the tariff nomenclature system of classification in use where the Customs declaration is made.
ABE	Declarant's reference number Unique reference number assigned to a document or a message by the declarant for identification purposes.
ABO	Originator's reference A unique reference assigned by the originator.
ABP	Declarant's Customs identity number Reference to the party whose posted bond or security is being declared in order to accept responsibility for a goods declaration and the applicable duties and taxes.
ABQ	Importer reference number Reference number assigned by the importer to identify a particular shipment for his own purposes.
ABT	Customs declaration number [1426] Number, assigned or accepted by Customs, to identify a Goods declaration.
ACD	Additional reference number Reference number provided in addition to another given reference.
ACE	Related document number Reference number identifying a related document.
ACK	Bank reference Cross reference issued by financial institution.
ACL	Principal reference number A number that identifies the principal reference.

## Used Codes

---

ACW	Reference number to previous message Reference number assigned to the message which was previously issued (e.g. in the case of a cancellation, the primary reference of the message to be cancelled will be quoted in this element).
ACX	Banker's acceptance Reference number for banker's acceptance issued by the accepting financial institution.
ADB	Matured certificate of deposit Reference number for certificate of deposit allocated by issuing financial institution.
ADC	Loan Reference number for loan allocated by lending financial institution.
ADD	Analysis number/test number Number given to a specific analysis or test operation.
ADE	Account number Identification number of an account.
AE	Authorization for expense (AFE) number A number that identifies an authorization for expense (AFE). GS1 Description: A number providing authorization for a party to incur an expense.
AEK	Payment order number A number that identifies a payment order.
AER	Project specification number Reference number identifying a project specification.
AES	Primary reference A number that identifies the primary reference.
AFO	Beneficiary's reference Reference of the beneficiary.
AFS	Beneficiary's bank reference Reference number of the beneficiary's bank.
AGA	Agreement to pay number A number that identifies an agreement to pay. GS1 Description: A reference number guaranteeing a payment.
AGB	Contract party reference number Reference number assigned to a party for a particular contract.
AGG	Dispute number Reference number to a dispute notice. GS1 Description: A reference number identifying a previously transmitted commercial dispute.



## Used Codes

---

AGT	Service group identification number Identification used for a group of services.
AGW	Scheme/plan number Reference number assigned to a service scheme or plan.
AHJ	Payee's reference number Reference number of the party to be paid.
AHL	Creditor's reference number Reference number of the party to whom a debt is owed.
AHM	Debtor's reference number Reference number of the party who owes an amount of money.
AHU	Request for quote number Reference number assigned by the requestor to a request for quote.
AID	Certificate of conformity Certificate certifying the conformity to predefined definitions.
AIJ	Customer's individual transaction reference number Customer's reference number allocated by the customer to one specific transaction.
AIK	Bank's individual transaction reference number Bank's reference number allocated by the bank to one specific transaction.
AIZ	Consolidated invoice number Invoice number into which other invoices are consolidated.
AJS	Agreement number A number specifying an agreement between parties.
AJT	Standard Industry Classification (SIC) number A number specifying a standard industry classification.
AKJ	Direct debit reference Reference number assigned to the direct debit operation.
AKM	Replenishment purchase order range start number Starting number of a range of purchase order numbers assigned by the buyer to vendor's replenishment orders.
AKO	Action authorization number A reference number authorizing an action.
ALK	Consignee's invoice number The invoice number assigned by a consignee.
ALL	Message batch number A number identifying a batch of messages.

## Used Codes

---

ALM	Previous delivery schedule number A reference number identifying a previous delivery schedule.
ALN	Physical inventory recount reference number A reference to a re-count of physically held inventory.
ALO	Receiving advice number A reference number to a receiving advice.
ALP	Returnable container reference number A reference number identifying a returnable container.
ALQ	Returns notice number A reference number to a returns notice.
ALR	Sales forecast number A reference number identifying a sales forecast.
ALS	Sales report number A reference number identifying a sales report.
ALT	Previous tax control number A reference number identifying a previous tax control number. GS1 Description: A reference number identifying a previous Tax Control (TAXCON) message number.
ALV	Registered capital reference Registered capital reference of a company.
AML	Replenishment purchase order range end number Ending number of a range of purchase order numbers assigned by the buyer to vendor's replenishment orders.
AMT	Goods and Services Tax identification number An identification number assigned to an organization collecting Goods and Services Taxes (GST).
ANJ	Authorization number A number which uniquely identifies an authorization.
ANL	Deposit reference number A reference number identifying a deposit. GS1 Description: A reference number identifying a physical deposit made to a financial account by a party through the bank branch network.
ANX	Clearing reference Reference allocated by a clearing procedure.

## Used Codes

---

ANZ	Direct debit reference Reference of the direct debit.
	Notes: This code value will be removed effective with directory D.02A.
AOA	Documentary payment reference Reference of the documentary payment.
AP	Accounts receivable number Reference number assigned by accounts receivable department to the account of a specific debtor.
APF	Price/sales catalogue response reference number A reference number identifying a response to a price/sales catalogue.
APG	General purpose message reference number A reference number identifying a general purpose message. EDIFACT
APH	Invoicing data sheet reference number A reference number identifying an invoicing data sheet.
API	Inventory report reference number A reference number identifying an inventory report.
APQ	Commercial account summary reference number A reference number identifying a commercial account summary.
AQQ	Activite Principale Exercee (APE) identifier The French industry code for the main activity of a company.
AQS	Nomenclature Activity Classification Economy (NACE) identifier A European industry classification code used to identify the activity of a company.
ARZ	Stock adjustment number A number identifying a stock adjustment.
ASE	Duty free products security number A security number allocated for duty free products.
ASF	Duty free products receipt authorisation number Authorisation number allocated for the receipt of duty free products.
ASG	Party information message reference Reference identifying a party information message.
ASI	Proof of delivery reference number A reference number identifying a proof of delivery which is generated by the goods recipient.
ASJ	Supplier's credit claim reference number A reference number identifying a supplier's credit claim.

## Used Codes

---

ASK	Picture of actual product Reference identifying the picture of an actual product.
ASL	Picture of a generic product Reference identifying a picture of a generic product.
ASO	Password Code used for authentication purposes.
ASV	Product data file number The number of a product data file.
ATB	Purchase for export Customs agreement number A number assigned by a Customs authority allowing the purchase of goods free of tax because they are to be exported immediately after the purchase. EDIFACT
AUB	Party reference The reference to a party
AUD	Collection reference A reference identifying a collection.
AUG	Importer's letter of credit reference Letter of credit reference issued by importer.
AUJ	Proposed purchase order reference number A reference number assigned to a proposed purchase order.
AUK	Application for financial support reference number Reference number assigned to an application for financial support.
AUL	Manufacturing quality agreement number Reference number of a manufacturing quality agreement.
AUQ	Customs binding ruling number Binding ruling number issued by customs.
AUR	Customs non-binding ruling number Non-binding ruling number issued by customs.
AUY	International Standard Industrial Classification (ISIC) code A code specifying an international standard industrial classification.
AUZ	Customs pre-approval ruling number Pre-approval ruling number issued by Customs.
AVB	Product characteristics directory A reference to a product characteristics directory. EDIFACT
AVD	Inventory report request number A reference to a product characteristics directory. EDIFACT

## Used Codes

---

AVG	<p>Slaughterhouse approval number          Veterinary licence number allocated by a national authority to a Slaughterhouse.          EDIFACT</p>
AVH	<p>Meat cutting plant approval number          Veterinary licence number allocated by a national authority to a meat cutting plant.          EDIFACT</p>
AVQ	<p>Place of packing approval number          Approval Number of the place where goods are packaged.          Approval number of the place where goods are packaged. In the meat sector, some additional information is required for traceability purposes: cutting party, slaughterhouse, ...</p>
AVS	<p>Mandate Reference          Reference to a specific mandate given by the relevant party for underlying business or action.</p>
AWB	<p>Air waybill number          Reference number assigned to an air waybill, see: 1001 = 740.</p>
AWS	<p>Hygienic Certificate number, national          Nationally set Hygienic Certificate number, such as sanitary, epidemiologic.</p>
AWT	<p>Administrative Reference Code          Reference number assigned by Customs to a 'shipment of excise goods'.</p>
AWV	<p>Phone number          A sequence of digits used to call from one telephone line to another in a public telephone network.</p>
AWW	<p>Buyer's fund number          A reference number indicating the fund number used by the buyer.          GS1 Note: Replaces GS1 Temporary Code BFN.</p>
AWX	<p>Company trading account number          A reference number identifying a company trading account.          GS1 Note: Replaces GS1 Temporary Code CAN.</p>
AWY	<p>Reserve goods identifier          A reference number identifying goods in stock which have been reserved for a party.          GS1 Note: Replaces GS1 Temporary Code GRN.</p>
AWZ	<p>Handling and movement reference number          A reference number identifying a previously transmitted cargo/goods handling and movement message.          GS1 Note: Replaces GS1 Temporary Code HN.</p>

## Used Codes

---

AXA	<p>Instruction to despatch reference number  A reference number identifying a previously transmitted instruction to despatch message.  GS1 Note: Replaces GS1 Temporary Code IDR.</p>
AXB	<p>Instruction for returns number  A reference number identifying a previously communicated instruction for return message.  GS1 Note: Replaces GS1 Temporary Code IRN.</p>
AXC	<p>Metered services consumption report number  A reference number identifying a previously communicated metered services consumption report.  GS1 Note: Replaces GS1 Temporary Code MSC.</p>
AXD	<p>Order status enquiry number  A reference number to a previously sent order status enquiry.  GS1 Note: Replaces GS1 Temporary Code OSC.</p>
AXE	<p>Firm booking reference number  A reference number identifying a previous firm booking.  GS1 Note: Replaces GS1 Temporary Code PFB.</p>
AXF	<p>Product inquiry number  A reference number identifying a previously communicated product inquiry.  GS1 Note: Replaces GS1 Temporary Code PIE.</p>
AXG	<p>Split delivery number  A reference number identifying a split delivery.  GS1 Note: Replaces GS1 Temporary Code SDR.</p>
AXH	<p>Service relation number  A reference number identifying the relationship between a service provider and a service client, e.g., treatment of a patient in a hospital, usage by a member of a library facility, etc.  GS1 Note: Replaces GS1 Temporary Code SNR.</p>
AXI	<p>Serial shipping container code  Reference number identifying a logisitc unit.  GS1 Note: Replaces GS1 Temporary Code SSC.</p>
AXJ	<p>Test specification number  A reference number identifying a test specification.  GS1 Note: Replaces GS1 Temporary Code TS.</p>
AXK	<p>Transport status report number  [1125] A reference number identifying a transport status report.  GS1 Note: Replaces GS1 Temporary Code TSE.</p>
AXL	<p>Tooling contract number  A reference number of the tooling contract.  GS1 Note: Replaces GS1 Temporary Code XB5.</p>

## Used Codes

---

AXM	<p>Formula reference number A reference number of a formula. GS1 Note: Replaces GS1 Temporary Code XB6.</p>
AXN	<p>Pre-agreement number A reference number identifying a pre-agreement. GS1 Note: Replaces GS1 Temporary Code XB7.</p>
AXO	<p>Product certification number Number assigned by a governing body (or their agents) to a product which certifies compliance with a standard. GS1 Note: Replaces GS1 Temporary Code XC1.</p>
AXP	<p>Consignment contract number Reference number identifying a consignment contract. GS1 Note: Replaces GS1 Temporary Code XC3.</p>
AXQ	<p>Product specification reference number Number assigned by the issuer to his product specification. GS1 Note: Replaces GS1 Temporary Code YA1.</p>
AXR	<p>Payroll deduction advice reference A reference number identifying a payroll deduction advice. GS1 Note: Replaces GS1 Temporary Code YA9.</p>
BC	<p>Buyer's contract number Reference number assigned by buyer to a contract.</p>
BFN	<p>Buyer's fund number (GS1 Temporary Code) A reference number indicating the fund number used by the buyer. GS1 Note: Code marked for deletion. Use value AWW instead.</p>
BM	<p>Bill of lading number Reference number assigned to a bill of lading, see: 1001 = 705.</p>
BN	<p>Booking reference number [1016] Reference number assigned by the carrier or his agent when cargo space is reserved prior to loading.</p>
BO	<p>Blanket order number Reference number assigned by the order issuer to a blanket order.</p>
BT	<p>Batch number/lot number Reference number assigned by manufacturer to a series of similar products or goods produced under similar conditions.</p>
CAN	<p>Company trading account number (GS1 Temporary Code) A reference number identifying a company trading account. GS1 Note: Code marked for deletion. Use value AWX instead.</p>
CBB	<p>Order shipment grouping reference A reference number identifying the grouping of purchase orders into one shipment. GS1 Note: Replaces GS1 Temporary Code YB4.</p>

## Used Codes

---

CD	Credit note number Reference number assigned to a credit note.
CED	Debit Letter number Reference number identifying the letter of debit document. GS1 Note: Replaces GS1 Temporary Code YB8.
CFF	Animal farm licence number Veterinary licence number allocated by a national authority to an animal farm. GS1 Note: Replaces GS1 Temporary Code YC3.
CH	Customer catalogue number Number identifying a catalogue for customer's usage.
CK	Cheque number Unique number assigned to one specific cheque.
CMR	Road consignment note number Reference number assigned to a road consignment note, see: 1001 = 730.
CN	Carrier's reference number Reference number assigned by carrier to a consignment.
CNE	Consolidated reference number (GS1 Temporary Code) A number identifying a consolidated reference.
CO	Buyers order number [1022] Reference number assigned by the buyer to an order.
COF	Call off order number A number that identifies a call off order.
CR	Customer reference number Reference number assigned by the customer to a transaction.
CT	Contract number Reference number of a contract concluded between parties.
CU	Consignor's reference number [1140] Reference number assigned by a consignor to a particular shipment for his own purposes or for those of the consignee.
CZ	Cooperation contract number Number issued by a party concerned given to a contract on cooperation of two or more parties.
DDC	Direct debit contract reference (SWIFT Code) A reference number identifying a direct debit contract.
DL	Debit note number Reference number assigned by issuer to a debit note.
DM	Document number [1004] Reference number assigned to the document by the issuer.



## Used Codes

---

DQ	Delivery note number Reference number assigned by the issuer to a delivery note.
ECN	External consolidation reference number (GS1 Temporary Code) A reference number assigned to identify an external consolidation.
EID	Economic operator identifier (EO-ID) (GS1 Temporary Code) Specify the economic operator identifier (EO-ID) number, e.g. in tobacco traceability.
ERC	External recap reference number (GS1 Temporary Code) A reference number identifying an external recap.
EX	Export licence number [1208] Reference number assigned by issuing authority to an Export Licence.
FC	Fiscal number Tax payer's number. Number assigned to individual persons as well as to corporates by a public institution; this number is different from the VAT registration number.
FF	Freight forwarder's reference number [1460] Reference number assigned to the consignment by the freight forwarder.
FI	File line identifier Number assigned by the file issuer or sender to identify a specific line.
FID	Facility identifier (F-ID) (GS1 Temporary Code) Identifies the place, for example the POS or warehouse where tobacco products are traded.
FV	File version number Number given to a version of an identified file.
FX	Foreign exchange contract number Reference number identifying a foreign exchange contract.
GC	Government contract number Number assigned to a specific government/public contract.
GN	Government reference number A number that identifies a government reference. GS1 Description: This code value should not be used to provide the tax identification number for a party (use code VA).
GRN	Goods reserve number (GS1 Temporary Code) A reference number identifying goods in stock which have been reserved for a party. GS1 Note: Code marked for deletion. Use value AWY instead.

## Used Codes

---

HN	<p>Handling and movement reference number (GS1 Temporary Code)</p> <p>A reference number identifying a previously transmitted cargo/goods handling and movement message.</p> <p>GS1 Note: Code marked for deletion. Use value AWZ instead.</p>
HS	<p>Harmonised system number</p> <p>Number specifying the goods classification under the Harmonised Commodity Description and Coding System of the Customs Co-operation Council (CCC).</p>
HWB	<p>House waybill number</p> <p>Reference number assigned to a house waybill, see: 1001 = 703.</p>
IA	<p>Internal vendor number</p> <p>Number identifying the company-internal vending department/unit.</p>
IDR	<p>Instruction to despatch reference number (GS1 Temporary Code)</p> <p>A reference number identifying a previously transmitted instruction to despatch message.</p> <p>GS1 Note: Code marked for deletion. Use value AXA instead.</p>
IP	<p>Import licence number</p> <p>[1106] Reference number assigned by the issuing authority to an Import Licence.</p>
IRN	<p>Instruction for returns number (GS1 Temporary Code)</p> <p>A reference number identifying a previously communicated instruction for return message.</p> <p>GS1 Note: Code marked for deletion. Use value AXB instead.</p>
IT	<p>Internal customer number</p> <p>Number assigned by a seller, supplier etc. to identify a customer within his enterprise.</p>
IV	<p>Invoice number</p> <p>[1334] Reference number assigned by the seller to a Commercial Invoice.</p>
LC	<p>Letter of credit number</p> <p>Reference number identifying the letter of credit document.</p>
LI	<p>Line item reference number</p> <p>(1156) Reference number identifying a particular line in a document.</p>
MB	<p>Master bill of lading number</p> <p>Reference number assigned to a master bill of lading, see: 1001 = 704.</p>
MF	<p>Manufacturer's part number</p> <p>Reference number assigned by the manufacturer to his product or part.</p>
MG	<p>Meter unit number</p> <p>Number identifying a unique meter unit.</p>
MH	<p>Manufacturing order number</p> <p>Reference number assigned by manufacturer for a given production quantity of products.</p>

## Used Codes

---

MR	<p>Message recipient</p> <p>A number that identifies the message recipient.</p> <p>GS1 Description: Party who receives the message.</p>
MS	<p>Message sender</p> <p>A number that identifies the message sender.</p> <p>GS1 Description: Party who sends the message.</p>
MSC	<p>Metered services consumption report (GS1 Temporary Code)</p> <p>A reference number identifying a previously communicated metered services consumption report.</p> <p>GS1 Note: Code marked for deletion. Use value AXC instead.</p>
MSS	<p>Manufacturer's material safety data sheet number</p> <p>A number that identifies a manufacturer's material safety data sheet.</p>
MWB	<p>Master air waybill number</p> <p>Reference number assigned to a master air waybill, see: 1001 = 741.</p>
ON	<p>Order number (buyer)</p> <p>[1022] Reference number assigned by the buyer to an order.</p>
OSE	<p>Order status enquiry (GS1 Temporary Code)</p> <p>A reference number to a previously sent order status enquiry.</p> <p>GS1 Note: Code marked for deletion. Use value AXD instead.</p>
PB	<p>Payer's financial institution account number</p> <p>Originated company account number (ACH transfer), check, draft or wire.</p>
PD	<p>Promotion deal number</p> <p>Number assigned by a vendor to a special promotion activity.</p>
PFB	<p>Firm booking reference number (GS1 Temporary Code)</p> <p>A reference number identifying a previous firm booking.</p> <p>GS1 Note: Code marked for deletion. Use value AXE instead.</p>
PIE	<p>Product inquiry number (GS1 Temporary Code)</p> <p>A reference number identifying a previously communicated product inquiry number.</p> <p>GS1 Note: Code marked for deletion. Use value AXF instead.</p>
PK	<p>Packing list number</p> <p>(1014) Reference number assigned to a packing list, see: 1001 = 271.</p>
PL	<p>Price list number</p> <p>Reference number assigned to a price list.</p> <p>GS1 Description: This code should be used to identify a Price/Sales Catalogue (PRICAT) message.</p>
POR	<p>Purchase order response number</p> <p>Reference number assigned by the seller to an order response.</p>

## Used Codes

---

PP	Purchase order change number Reference number assigned by a buyer for a revision of a purchase order.
PQ	Payment reference Reference number assigned to a payment.
PR	Price quote number Reference number assigned by the seller to a quote.
PW	Prior purchase order number Reference number of a purchase order previously sent to the supplier.
PY	Payee's financial institution account number Receiving company account number (ACH transfer), check, draft or wire.
RA	Remittance advice number A number that identifies a remittance advice.
RAK	Rack identification (GS1 Temporary Code) Identification of a warehouse rack in the location for shipment pick-up.
RCE	Recap number (GS1 Temporary Code) A reference number identifying a recap.
RCN	Railway consignment note number Reference number assigned to a rail consignment note, see: 1001 = 720.
RF	Export reference number Reference number given to an export shipment.
SB	Sales region number A number that identifies a sales region.
SD	Sales department number A number that identifies a sales department.
SDR	Split delivery reference number (GS1 Temporary Code) A reference number identifying a split delivery. GS1 Note: Code marked for deletion. Use value AXG instead.
SE	Serial number Identification number of an item which distinguishes this specific item out of an number of identical items.
SN	Seal number [9308] Identification number on Customs or other seals affixed to containers or other transport units.
SNR	Service relation number (GS1 Temporary Code) A number used to identify a database entry which records recurring services, e.g., treatment of a patient in a hospital, usage by a member of a library facility, etc. GS1 Note: Code marked for deletion. Use value AXH instead.

## Used Codes

---

SRN	<p>Shipment reference number Reference number assigned to a shipment. GS1 Description: Reference number assigned by a consignor to a particular shipment for his own purposes or for those of the consignee.</p>
SS	<p>Seller's reference number Reference number assigned to a transaction by the seller.</p>
SSC	<p>Serial shipping container code (GS1 Temporary Code) Reference number identifying a serial shipping container or package. GS1 Note: Code marked for deletion. Use value AXI instead.</p>
SZ	<p>Specification number Number assigned by the issuer to his specification.</p>
TAU	<p>Aggregated level unique identifier (aUI) (GS1 Temporary Code) Reference the aggregated level unique identifier (aUI), e.g. in tobacco traceability.</p>
TIN	<p>Transport instruction number A reference number identifying a transport instruction. EDIFACT</p>
TL	<p>Tax exemption licence number Number assigned by the tax authorities to a party indicating its tax exemption authorization. This number could relate to a specified business type, a specified local area or a class of products.</p>
TP	<p>Test report number Reference number identifying a test report document relevant to the product.</p>
TRB	<p>Tribunal place registration number (GS1 Temporary Code) Registration number of a company at the tribunal place.</p>
TS	<p>Test specification number (GS1 Temporary Code) A reference number identifying a test specification. GS1 Note: Code marked for deletion. Use value AXJ instead.</p>
TSE	<p>Transport status number (GS1 Temporary Code) A reference number identifying a transport status message. GS1 Note: Code marked for deletion. Use value AXK instead.</p>
TUU	<p>Aggregated level unique identifier (upUI) (GS1 Temporary Code) Identifies the single pack of cigarettes issued by a central EU repository.</p>
UC	<p>Ultimate customer's reference number The originator's reference number as forwarded in a sequence of parties involved.</p>

## Used Codes

---

UCN	<p>Unique consignment reference number (1202) Unique reference of a consignment (UCRN) used for identification purposes in documents and messages exchanged between parties in international trade. See also: Unique Identifier Code (UNIC) in UN/ECE Recommendation No. 8, March 1992.</p>
UO	<p>Ultimate customer's order number The originator's order number as forwarded in a sequence of parties involved.</p>
VA	<p>VAT registration number Unique number assigned by the relevant tax authority to identify a party for use in relation to Value Added Tax (VAT).</p>
VN	<p>Order number (supplier) Reference number assigned by supplier to a buyer's purchase order.</p>
XA	<p>Company/place registration number Company registration and place as legally required.</p>
XA4	<p>Account servicing bank reference (SWIFT Code) A reference number allocated by an account servicing bank.</p>
XA5	<p>Customer to customer reference number (SWIFT Code) A reference number exchanged between customers.</p>
XA6	<p>Third party reference number (SWIFT Code) A number used to identify references related to third parties.</p>
XA8	<p>Credit card number (SWIFT Code) A reference number identifying a credit card.</p>
XB1	<p>Clearing number (SWIFT Code) A reference number identifying a clearing.</p>
XB5	<p>Tooling contract number (GS1 Temporary Code) Number of the tooling contract. GS1 Note: Code marked for deletion. Use value AXL instead.</p>
XB6	<p>Formula number (GS1 Temporary Code) Number of the formula. GS1 Note: Code marked for deletion. Use value AXM instead.</p>
XB7	<p>Pre-agreement number (GS1 Temporary Code) Number identifying a pre-agreement. GS1 Note: Code marked for deletion. Use value AXN instead.</p>
XC1	<p>Product certification number (GS1 Temporary Code) Number assigned by a governing body (or their agents) to a product which certifies compliance with a standard. GS1 Note: Code marked for deletion. Use value AXO instead.</p>
XC3	<p>Consignment contract number (GS1 Temporary Code) Reference number identifying a consignment contract. GS1 Note: Code marked for deletion. Use value AXP instead.</p>

## Used Codes

---

YA1	Product specification reference number (GS1 Temporary Code) Number assigned by the issuer to his product specification. GS1 Note: Code marked for deletion. Use value AXQ instead.
YA3	Numbering per year (GS1 Temporary Code) Financial statement should be identified consecutively numbered per year.
YA6	Bank statement number (SWIFT Code) A reference number identifying a bank statement.
YA9	Payroll deduction advice reference (GS1 Temporary Code) A reference number identifying a payroll deduction advice. GS1 Note: Code marked for deletion. Use value AXR instead.
YB4	Order shipment grouping reference (GS1 Temporary Code) A reference number identifying the grouping of purchase orders into one shipment. GS1 Note: Code marked for deletion. Use value CBB instead.
YB8	Debit Letter (GS1 Temporary Code) Reference number identifying the letter of debit document. GS1 Note: Code marked for deletion. Use value CED instead.
YC1	Additional party identification (GS1 Temporary Code) Reference number to an additional party identification. This number may be the internal trading partner identification number used by a party to identify its trading parties.
YC3	Farm approval number (GS1 Temporary Code) Veterinary licence number allocated by a national authority to an animal farm.
YC6	Electrical and Electronic Equipment Producer registration number (GS1 Temporary Code) National registration number of the producers of Electrical and Electronic Equipment
YC7	Batteries and Accumulators Producer registration number (GS1 Temporary Code) National registration number of the producers of Batteries and Accumulators
ZZZ	Mutually defined reference number Number based on party agreement.
<b>1225</b>	Message function code Code indicating the function of the message.
7	Duplicate The message is a duplicate of a previously generated message.
9	Original Initial transmission related to a given transaction.

**Used Codes**

<b>1373</b>	Document status code Code specifying the status of a document.
1	Accepted The specified document is accepted.
2	Accompanying goods Notice that a specific document will be accompanying the goods.
3	Conditionally accepted The specified document is conditionally accepted.
4	To arrive by separate EDI message Notice that a specific document/message will be transmitted via a separate EDI message.
5	Information only Notice that the specific document or message is for information only.
6	To arrive by manual means Notice that a specific document or message will not be sent via EDI.
7	To be raised and sent Request for a specific message to be formatted and transmitted or a request for a specific document to be raised and sent.
8	Rejected The specified document is rejected.
9	To be printed The document or message is to be printed.
10	Document currently valid Specific document is currently valid.
17	Document with the goods Document not attached to the Customs declaration but is attached to the goods.
39	On hold The document or message will not be processed until further release information. GS1 Note: Replaces GS1 Temporary Code X1.
X1	On hold (GS1 Temporary Code) The document or message will not be processed until further release information. GS1 Note: Code marked for deletion. Use value 39 instead.
<b>2005</b>	Date or time or period function code qualifier Code qualifying the function of a date, time or period.



**Used Codes**

1	Service completion date/time, actual Actual date/time on which the service was completed.
2	Delivery date/time, requested Date on which buyer requests goods to be delivered.
3	Invoice date/time [2376] Date when a Commercial Invoice is issued.
4	Order date/time [2010] Date when an order is issued.
7	Effective date/time Date and/or time at which specified event or document becomes effective.
8	Order received date/time Date/time when the purchase order is received by the seller.
9	Processing date/time Date/time of processing.
10	Shipment date/time, requested Date on which goods should be shipped or despatched by the supplier.
11	Despatch date and/or time (2170) Date/time on which the goods are or are expected to be despatched or shipped.
12	Terms discount due date/time Date by which payment should be made if discount terms are to apply.
13	Terms net due date Date by which payment must be made.
14	Payment date/time, deferred Date/time when instalments are due.
15	Promotion start date/time Date/time when promotion activities begin.
16	Promotion end date/time Date/time when promotion activities end.
17	Delivery date/time, estimated Date and/or time when the shipper of the goods expects delivery will take place.
18	Installation date/time/period The date/time/period of the act, or an instance of installing something or someone.
35	Delivery date/time, actual Date/time on which goods or consignment are delivered at their destination.

## Used Codes

---

36	Expiry date Date of expiry of the validity of a referenced document, price information or any other referenced data element with a limited validity period.
37	Ship not before date/time Goods should not be shipped before given date/time.
38	Ship not later than date/time Date/time by which the goods should have been shipped.
44	Availability Date/time when received item is available.
50	Goods receipt date/time Date/time upon which the goods were received by a given party.
55	Confirmed date/time Date/time which has been confirmed.
58	Clearance date (Customs) (3080) Date on which Customs formalities necessary to allow goods to be exported, to enter home use, or to be placed under another Customs procedure has been accomplished (CCC).
59	Inbond movement authorization date Inland movement authorization date.
61	Cancel if not delivered by this date The date on which cancellation should take place, if delivery has not occurred.
63	Delivery date/time, latest Date identifying a point of time after which goods shall not or will not be delivered.
64	Delivery date/time, earliest Date identifying a point in time before which the goods shall not be delivered.
67	Delivery date/time, current schedule Delivery Date deriving from actual schedule.
69	Delivery date/time, promised for [2138] Date by which, or period within which, the merchandise should be delivered to the buyer, as agreed between the seller and the buyer (generic term).
71	Delivery date/time, requested for (after and including) Delivery is requested to happen after or on given date.
72	Delivery date/time, promised for (after and including) Delivery might take place earliest at given date.
73	Guarantee period The period for which the guarantee is or will be granted.

**Used Codes**

74	Delivery date/time, requested for (prior to and including) Delivery is requested to happen prior to or including the given date.
75	Delivery date/time, promised for (prior to and including) Delivery might take place latest at given date.
76	Delivery date/time, scheduled for The date/time for which delivery is scheduled.
79	Shipment date/time, promised for Shipment might happen at given date/time.
90	Report start date The date on which a report is to begin.
91	Report end date The date on which a report is to end.
94	Production/manufacture date Date on which goods are produced.
95	Bill of lading date Date as specified on the bill of lading.
99	Quotation opening date The date on which the quotation has been or may be opened.
100	Product ageing period before delivery Period of time before delivery during which the product is ageing.
102	Health problem period Period of time of health problem. GS1 Description: Period of time of exceptional health problems.
117	Delivery date/time, first First possible date/time for delivery.
119	Test completion date Date when a test has been completed.
124	Despatch note date [2218] Date when a Despatch Note is issued.
126	Contract date [2326] Date when a Contract is agreed.
128	Delivery date/time, last Date when the last delivery should be or has been accomplished.
129	Exportation date Date when imported vessel/merchandise last left the country of export for the country of import.

## Used Codes

---

131	Tax point date Date on which tax is due or calculated.
132	Arrival date/time, estimated (2348) Date/time when carrier estimates that a means of transport should arrive at the port of discharge or place of destination.
133	Departure date/time, estimated Date/time when carrier estimates that a means of transport should depart at the place of departure.
134	Rate of exchange date/time Date/time on which the exchange rate was fixed.
136	Departure date/time [2280] Date (and time) of departure of means of transport.
137	Document/message date/time (2006) Date/time when a document/message is issued. This may include authentication.
138	Payment date [2034] Date on which an amount due is made available to the creditor, in accordance with the terms of payment.
140	Payment due date Date/time at which funds should be made available.
143	Acceptance date/time of goods [2126] Date on which the goods are taken over by the carrier at the place of acceptance (CMR 4).
147	Expiry date of export licence [2078] Date of expiry of the validity of an Export Licence.
151	Importation date Date on which goods are imported, as determined by the governing Customs administration.
152	Exportation date for textiles Date when imported textiles last left the country of origin for the country of importation.
154	Acceptance date of document The date on which a document was accepted. GS1 Description: Date on which a document was, or will be, accepted.
155	Accounting period start date The first date of an accounting period.
156	Accounting period end date The last date of an accounting period.

**Used Codes**

157	Validity start date The first date of a period for which something is valid.
162	Release date of supplier Date when the supplier released goods.
165	Tax period start date Date when a tax period begins.
166	Tax period end date Date when a tax period ends.
167	Charge period start date The charge period's first date.
168	Charge period end date The charge period's last date.
169	Lead time Time required between order entry till earliest goods delivery.
171	Reference date/time Date/time on which the reference was issued.
174	Advise after date/time The information must be advised after the date/time indicated.
175	Advise before date/time The information must be advised before the date/time indicated.
176	Advise completed date/time The advise has been completed at the date indicated.
177	Advise on date/time The information must be advised on the date/time indicated.
178	Arrival date/time, actual [2106] Date (and time) of arrival of means of transport.
179	Booking date/time Date at which the booking was made.
180	Closing date/time Final date for delivering cargo to a liner ship.
182	Issue date Date when a document/message has been or will be issued.
186	Departure date/time, actual (2280) Date (and time) of departure of means of transport.
189	Departure date/time, scheduled Date (and time) of scheduled departure of means of transport.

**Used Codes**

190	Transshipment date/time Date and time of the transfer of the goods from one means of transport to another.
191	Delivery date/time, expected Date/time on which goods are expected to be delivered.
192	Expiration date/time of customs document Date on which validity of a customs document expires.
193	Execution date The date when ordered bank initiated the transaction.
194	Start date/time Date/time on which a period starts.
195	Expiry date of import licence [2272] Date of expiry of the validity of an Import Licence.
199	Positioning date/time of goods The date and/or time the goods have to be or have been positioned.
200	Pick-up/collection date/time of cargo Date/time at which the cargo is picked up.
202	Posting date The date when an entry is posted to an account.
203	Execution date/time, requested The date/time on which the ordered bank is requested to initiate the payment order, as specified by the originator (e.g. the date of the debit).
206	End date/time Date/time on which a period (from - to) ends.
209	Value date Date on which the funds are at the disposal of the beneficiary or cease to be at the disposal of the ordering customer.
211	360/30 Calculation is based on year of 360 days, month of 30 days.
212	360/28-31 Calculation is based on year of 360 days, month of 28-31 days.
213	365-6/30 Calculation is based on year of 365-6 days, month of 30 days.
214	365-6/28-31 Calculation is based on year of 365-6 days, month of 28-31 days.
215	365/28-31 Calculation is based on year of 365 days, month of 28-31 days.

**Used Codes**

216	365/30 Calculation is based on year of 365 days, month of 30 days.
218	Authentication/validation date/time The date/time of authentication and/or validation.
219	Crossborder date/time Date/time at which goods are transferred across a country border.
221	Interest period Number of days used for the calculation of interests.
222	Presentation date, latest Latest date for presentation of a document.
223	Delivery date/time, deferred New date and time of delivery calculated on basis of a consignee's requirement (chargeable).
227	Beneficiary's banks due date Date on which funds should be made available to the beneficiary's bank.
231	Arrival date/time, earliest Date/time of earliest arrival of means of transport.
232	Arrival date/time, scheduled Date (and time) of scheduled arrival of means of transport.
234	Collection date/time, earliest The transport order may be issued before the goods are ready for picking up. This date/time indicates from when on the carrier can have access to the consignment.
235	Collection date/time, latest In relation with the arrangements agreed between buyer and seller or between sender and main transport it may be necessary to specify the latest collection date/time.
255	Availability due date Date when ordered items should be available at a specified location.
257	Calculation date/time/period The date/time/period on which a calculation will take, or has taken, place.
260	Valuation date (Customs) Date when Customs valuation was made.
261	Release date/time Date/time assigned to identify the release of a set of rules, conditions, conventions, productions, etc.
263	Invoicing period Period for which an invoice is issued.

**Used Codes**

265	Due date The date on which some action should occur.
266	Validation date The date on which something was made valid, ratified or confirmed. GS1 Description: The date on which the validation of a document or message has taken place.
267	Rate/price date/time Date/time on which a rate/price is determined.
273	Validity period Dates (from/to)/period referenced documents are valid.
282	Confirmation date lead time Lead time is referenced to the date of confirmation.
306	Work period Period of execution of works.
310	Received date/time Date/time of receipt.
315	Agreement to pay date Date on which the debtor agreed to pay.
321	Promotion date/period Date/period relevant for specific promotion activities.
322	Accounting period Self-explanatory. GS1 Description: Period related to a company's accounting procedures/fiscal calendar.
324	Processing date/period Date/period a specific process happened/will happen.
325	Tax period Period a tax rate/tax amount etc. is applicable. GS1 Description: A period which is designated by tax authorities, e.g. VAT period.
326	Charge period Period a specified charge is valid for.
328	Payroll deduction date/time Date/time of a monetary deduction made from the salary of a person on a payroll.
334	Status change date/time Date/time when a status changes.
349	Packing end date Date on which packing completed.



**Used Codes**

350	Test start date Date when a test has been started.
351	Inspection date Date of inspection.
356	Sales date, and or time, and or period The date, and or time, and or period on which a sale took place.
357	Cancel if not published by this date Cancel if not published by this date.
358	Scheduled for delivery on or after Scheduled for delivery on or after the specified date, and or time.
359	Scheduled for delivery on or before Scheduled for delivery on or before specified date and or time.
360	Sell by date The date by which a product should be sold.
361	Best before date The best before date.
362	End availability date The end date of availability.
363	Total shelf life period A period indicating the total shelf life of a product.
364	Minimum shelf life remaining at time of despatch period Period indicating the minimum shelf life remaining for a product at the time of leaving the supplier.
365	Packaging date The date on which the packaging of a product took place.
366	Inventory report date Date on which a inventory report is made.
367	Previous meter reading date Date on which the previous reading of a meter took place.
368	Latest meter reading date Date on which the latest reading of a meter took place.
369	Date and or time of handling, estimated The date and or time when the handling action is estimated to take place.
381	Product Lifespan at time of production (GS1 Temporary Code) The total lifespan of a product at the time of its production.
382	Earliest sale date The earliest date on which the product may be made available for sale.

**Used Codes**

383	Cancel if not shipped by this date Cancel the order if goods not shipped by this date. GS1 Description: Cancel the identified order if it has not been shipped/despatched by this date.
417	Previous booking date/time Date/time at which the previous booking was made.
418	Minimum shelf life remaining at time of receipt The minimum shelf life remaining at the time of receipt.
419	Forecast period A period for which a forecast applies. GS1 Description: A validity period for a forecast.
423	First date of ordering The first date on which ordering may take place.
424	Last date of ordering The last date on which ordering may take place.
434	Maturity date Date at which maturity occurs.
447	Creditor's requested value date Date on which the creditor requests to be credited.
448	Referenced item creation date Creation date of referenced item.
454	Accounting value date Date against which the entry has to be legally allocated.
496	Reinstatement date Identifies the date of reinstatement.
506	Back order delivery date/time/period The date/time/period during which the delivery of a back order will take, or has taken, place.
530	Fumigation date and/or time The date/or time on which fumigation is to occur or has taken place.
531	Payment period A period of time in which a payment has been or will be made.
536	Review date Date the item was or will be reviewed.
541	First published date Date when material was first published.

**Used Codes**

557	Returned date Date return takes place. GS1 Description: Date by which goods must be, or have been, returned.
656	Age Length of time that a person or thing has existed. GS1 Description: Length of time that a person or animal has lived or a thing has existed.
684	Deletion date The date on which deletion occurs.
685	First sale date and/or time and/or period The first date, and/or time, and/or period a product was sold.
686	Last sale date and/or time and/or period The last date, and/or time, and/or period a product was sold.
706	File generation date and/or time Date and, or time of file generation.
743	Purchase order latest possible change date Date identifying a point of time after which a purchase order cannot be changed.
748	Open period Code identifying the period during which something is, was or will be open.
750	Before date The specified before date. EDIFACT
751	After date The specified after date. EDIFACT
753	Maturity date, optimal Date at which optimal maturity occurs. EDIFACT
754	Product ageing duration, maximum Maximum period of time during which the product is ageing. EDIFACT
755	Product ageing duration, minimum Minimum period of time during which the product is ageing. EDIFACT
758	Trade item ship date/time, earliest possible The earliest date/time that the trade item can be shipped. It indicates the earliest date that the trade item can be shipped. This is independent of any specific ship-from location.

## Used Codes

---

759	Trade item ship date/time, latest possible The latest date/time that the trade item can be shipped. It indicates the latest date that the trade item can be shipped. This is independent of any specific ship-from location.
760	Start date/time, maximum buying quantity The date/time from which the maximum buying quantity may be purchased. The start date for when the maximum buying quantity is available to the trading partner.
761	Start date/time, minimum buying quantity The date/time from which the minimum buying quantity may be purchased. The start date for when the minimum buying quantity is available to the trading partner.
762	Marketing campaign end date/time, suggested The date and or time suggested for the marketing campaign to end. The date suggested by the supplier for the campaign to end. It indicates the end of a marketing campaign.
763	Marketing campaign start date/time, suggested The date and or time suggested for the marketing campaign to start. The date suggested by the supplier for the campaign to start. It indicates the beginning of a marketing campaign.
764	Start availability date The start date of availability. Indicates the start date of the trade item's seasonal availability.
765	Seasonal availability calendar year The calendar year of the season in which the trade item is available.
766	Goods pickup lead time Minimum time required between order entry and goods release for pick-up. Time (in weeks, days, hours ...) required between order entry and the earliest goods release (use for pick-up, not use for delivery).
767	Change date/time, latest Most recent date and/or time that the information has been changed. A system generated value identifying the date and time a record was last updated.
768	End date/time, maximum buying quantity The date and/or time until which the maximum buying quantity may be purchased. The end date for when the maximum buying quantity is no longer available to the trading partner.
769	End date/time, minimum buying quantity The date and/or time until which the minimum buying quantity may be purchased. The end date for when the minimum buying quantity is no longer available to the trading partner.

## Used Codes

---

770	End date/time of exclusivity The date and/or time until which a product is exclusive. The Date & Time at which a product is no longer exclusive to that trading partner.
772	Handling start date and/or time, actual The actual date and/or time when the start of the handling action takes place.
773	Handling end date and/or time, estimated The date and/or time when the end of the handling action is estimated to take place.
774	Handling end date and/or time, actual The actual date and/or time when the end of the handling action takes place.
775	Minimum product lifespan for consumer The minimum life span of the product remaining after selling it to the consumer, i.e. between the "sell by date" and the "use by date" of the product.
789	Opened trade item life span The number of days the trade item that had been opened can remain on the shelf and must then be removed.
793	Reprocessing date/time Date/time on which goods previously produced are re-processed.
794	First returnable date/time The first date/time on or after which items can be returned.
795	Community visibility date/time The date/time from which information becomes visible to the target community.
796	Catch date/time Date/time of catch.
799	Validity end date The last date of a period for which something is valid. GS1 Note: Replaces GS1 Temporary Code 21E.
800	Next status report date Date of the next status report. GS1 Note: Replaces GS1 Temporary Code 40E.
801	Service connection date/time, actual The date/time on which a service was connected, e.g. telephone, water, etc. GS1 Note: Replaces GS1 Temporary Code 44E.
802	Service disconnection date/time, actual The date/time on which a service was DISconnected, e.g. telephone, water, etc. GS1 Note: Replaces GS1 Temporary Code 45E.

## Used Codes

---

803	Empty equipment required date/time/period Date/time/period on which empty equipment is required. GS1 Note: Replaces GS1 Temporary Code 50E.
804	Product sterilisation date Date on which a product was sterilised. GS1 Note: Replaces GS1 Temporary Code 90E.
805	Stock demand cover period, expected A period of time when stocks are expected to cover demand for a product. GS1 Note: Replaces GS1 Temporary Code 96E.
806	Shipment date/time, expected Date and/or time when shipment is expected. GS1 Note: Replaces GS1 Temporary Code X13.
807	Slaughtering date/time Date/time of slaughtering
808	Animal birth date/time Date/time when an animal was born
809	Seasonal availability end date Indicates the end date of the trade item's seasonal availability
822	Delivery place booking date/time Date/time at which a booking was made at the delivery place.
823	Pickup place booking date/time Date/time at which a booking was made at the pickup place.
21E	End validity date (GS1 Temporary Code) Date indicating the end date of a validity period. GS1 Note: Code marked for deletion. Use value 799 instead.
40E	Next status date (GS1 Temporary Code) The next date on which a status report will be provided. GS1 Note: Code marked for deletion. Use value 800 instead.
41E	Product lifespan from time of production (GS1 Temporary Code) An indication of the lifespan of a product from its time of production.
44E	Connection date/time (GS1 Temporary Code) The date/time on which a service was connected, e.g. telephone, water, etc. Connection date/time
45E	Disconnection date/time (GS1 Temporary Code) The date/time on which a service was disconnected, e.g. telephone, water, etc. GS1 Note: Code marked for deletion. Use value 802 instead.
46E	Order completion date/time (GS1 Temporary Code) The date/time on which an order was completed.

## Used Codes

---

50E	<p>Empty equipment required date/time/period (GS1 Temporary Code) Date on which empty equipment is required. GS1 Note: Code marked for deletion. Use value 803 instead.</p>
54E	<p>Stuffing date/time (GS1 Temporary Code) The date/time on which the stuffing of a container is to take place, or has taken place.</p>
55E	<p>Un-stuffing date/time (GS1 Temporary Code) The date/time on which the un-stuffing of a container is to take place, or has taken place.</p>
61B	<p>Cancel if not delivered by this date unless title not published at time (GS1 Temporary Code) Cancel the product ordered if it has not been delivered by this date unless it had not been published at the time of order. GS1 Note: Code marked for deletion.</p>
63B	<p>Latest availability date if not yet despatched (GS1 Temporary Code) The latest availability date required for a product or order if it has not already been despatched.</p>
90E	<p>Product sterilisation date (GS1 Temporary Code) Date on which a product was sterilised. GS1 Note: Code marked for deletion. Use value 804 instead.</p>
91E	<p>First freezing date (GS1 Temporary Code) Date on which a product was first frozen.</p>
92E	<p>Pension deduction payment date (GS1 Temporary Code) Date when the deduction was made from the salary of the employee.</p>
93E	<p>Professional risk deduction payment date (GS1 Temporary Code) Date when the risk deduction was made from the salary of the employee.</p>
94E	<p>Health care deduction payment date (GS1 Temporary Code) Date when health care deduction was made.</p>
96E	<p>Stock cover period (GS1 Temporary Code) A period of time when all stocks are expected to cover demand for a product. GS1 Note: Code marked for deletion. Use value 805 instead.</p>
98E	<p>Discharge date/time, start (GS1 Temporary Code) Date/time when all discharge operations on the transport means have actually been started.</p>
X13	<p>Expect to ship by (GS1 Temporary Code) The consignment is expected to be shipped by this date and/or time. GS1 Note: Code marked for deletion. Use value 806 instead.</p>
X14	<p>Requested for delivery week commencing (GS1 Temporary Code) Code requesting delivery of an order or order line during a specified week.</p>

**Used Codes**

X19	Material Safety Data Sheet issue date (GS1 Temporary Code) A date when a Material Safety Data Sheet has been or will be issued.
X20	Slaughter date/time (GS1 Temporary Code) Date/time of slaughtering of an animal. GS1 Note: Code marked for deletion. Use value 807 instead.
X21	Animal Birth date/time (GS1 Temporary Code) Date/time when an animal was born. For traceability purposes. GS1 Note: Code marked for deletion. Use value 808 instead.
X49	Seasonal availability end date (GS1 Temporary Code) Indicates the end date of the trade item's seasonal availability. GS1 Note: Code marked for deletion. Use value 809 instead.
X50	Committed quantity announcement date (GS1 Temporary Code) The date when quantity committed by store could be announced to the supply chain of the retailer.
XF2	Date of issue and maturity (SWIFT Code) Date when a document/message has been issued and becomes mature.
YB9	Total credits (SWIFT Code) The total value of credits to a financial account.
<b>2379</b>	Date or time or period format code Code specifying the representation of a date, time or period.
2	DDMMYY Calendar date: D = Day; M = Month; Y = Year.
101	YYMMDD Calendar date: Y = Year; M = Month; D = Day.
102	CCYYMMDD Calendar date: C = Century ; Y = Year ; M = Month ; D = Day.
104	MMWW-MMWW A period of time specified by giving the start week of a month followed by the end week of a month. Data is to be transmitted as consecutive characters without hyphen.
107	DDD Day's number within a specific year: D = Day.
108	WW Week's number within a specific year: W = Week.
109	MM Month's number within a specific year: M = Month.
110	DD Day's number within is a specific month.



## Used Codes

---

201	YYMMDDHHMM Calendar date including time without seconds: Y = Year; M = Month; D = Day; H = Hour; M = Minute.
203	CCYYMMDDHHMM Calendar date including time with minutes: C=Century; Y=Year; M=Month; D=Day; H=Hour; M=Minutes.
204	CCYYMMDDHHMMSS Calendar date including time with seconds: C=Century;Y=Year; M=Month; D=Day;H=Hour;M=Minute;S=Second.
401	HHMM Time without seconds: H = Hour; m = Minute.
501	HHMMHHMM Time span without seconds: H = Hour; m = Minute;.
502	HHMMSS-HHMMSS Format of period to be given without hyphen.
602	CCYY Calendar year including century: C = Century; Y = Year.
609	YYMM Month within a calendar year: Y = Year; M = Month.
610	CCYMM Month within a calendar year: CC = Century; Y = Year; M = Month.
615	YYWW Week within a calendar year: Y = Year; W = Week 1st week of January = week 01.
616	CCYYWW Week within a calendar year: CC = Century; Y = Year; W = Week (1st week of January = week 01).
713	YYMMDDHHMM-YYMMDDHHMM Format of period to be given in actual message without hyphen.
715	YYWW-YYWW A period of time specified by giving the start week of a year followed by the end week of year (both not including century). Data is to be transmitted as consecutive characters without hyphen.
717	YYMMDD-YYMMDD Format of period to be given in actual message without hyphen.
718	CCYYMMDD-CCYYMMDD Format of period to be given without hyphen.

## Used Codes

---

719	CCYYMMDDHHMM-CCYYMMDDHHMM A period of time which includes the century, year, month, day, hour and minute. Format of period to be given in actual message without hyphen.
720	DHHMM-DHHMM Format of period to be given without hyphen (D=day of the week, 1=Monday; 2=Tuesday; ... 7=Sunday).
801	Year To indicate a quantity of years.
802	Month To indicate a quantity of months.
803	Week To indicate a quantity of weeks.
804	Day To indicate a quantity of days.
805	Hour To indicate a quantity of hours.
806	Minute To indicate a quantity of minutes.
810	Trimester To indicate a quantity of trimesters (three months).
811	Half month To indicate a quantity of half months.
21E	DDHHMM-DDHHMM (GS1 Temporary Code) Format of period to be given in actual message without hyphen.
<b>3035</b>	Party function code qualifier Code giving specific meaning to a party.
AB	Buyer's agent/representative Third party who arranged the purchase of merchandise on behalf of the actual buyer.
ACD	Party has access to all non publicly available data (GS1 Temporary Code) The identified party has access to all non publicly available pricing and non-pricing data associated with the current product.
ACN	Party has access only to non publicly available non-pricing data (GS1 Temporary Code) The identified party has access only to the non publicly available non-pricing data associated with the current product.

## Used Codes

---

ACP	<p>Party has access only to non publicly available pricing data (GS1 Temporary Code)</p> <p>The identified party has access only to the non publicly available pricing data associated with the current product.</p>
AE	<p>Declarant's agent/representative</p> <p>Any natural or legal person who makes a declaration to an official body on behalf of another natural or legal person, where legally permitted (CCC).</p>
AG	<p>Agent/representative</p> <p>(3196) Party authorized to act on behalf of another party.</p>
AP	<p>Accepting party</p> <p>(3352) Party accepting goods, products, services etc.</p>
AS	<p>Account servicing financial institution</p> <p>Identifies the financial institution servicing the account(s).</p>
BE	<p>Beneficiary</p> <p>The ultimate recipient of the funds. Normally the account owner who is reimbursed by the payor.</p>
BF	<p>Beneficiary's bank</p> <p>Identifies the account servicer for the beneficiary or the payee.</p>
BK	<p>Financial institution</p> <p>Party acting as financial institution.</p>
BL	<p>Bill of lading recipient</p> <p>Party to receive B/L.</p>
BO	<p>Broker or sales office</p> <p>Party acting in the name of the seller as broker or as sales office.</p>
BQ	<p>Cheque drawn bank</p> <p>Identifies the bank on which the cheque should be drawn, as instructed by the ordering customer.</p>
BS	<p>Bill and ship to</p> <p>Party receiving goods and relevant invoice.</p>
BY	<p>Buyer</p> <p>Party to whom merchandise and/or service is sold.</p>
CA	<p>Carrier</p> <p>(3126) Party undertaking or arranging transport of goods between named points.</p>
CG	<p>Carrier's agent</p> <p>Party authorized to act for or on behalf of carrier.</p>
CH	<p>Connecting carrier</p> <p>Owner or operator of a transportation conveyance to which goods in a given transaction will be transferred.</p>

## Used Codes

---

CK	Empty equipment despatch party Party from whose premises empty equipment will be or has been despatched.
CM	Customs Identification of customs authority relevant to the transaction or shipment.
CN	Consignee (3132) Party to which goods are consigned.
CO	Corporate office Identification of the Head Office within a company.
COD	Quotation requesting party The party sending the requests for quotation. GS1 Note: Replaces GS1 Temporary Code QP. EDIFACT
CPE	Central payment service (GS1 Temporary Code) Master of the conveyance. GS1 Description: A party providing central (or consolidated payment) services.
CPU	Central procurement party (GS1 Temporary Code) Party responsible for all aspects (e.g. tenders, orders, invoices, ..) of procurement.
CQ	Cheque order Party to which the cheque will be ordered, when different from the beneficiary.
CR	Empty equipment return party Party to whose premises empty equipment will be or has been returned.
CRB	Creditor's bank (SWIFT Code) Identifies the account servicer for the creditor.
CRE	Creditor (SWIFT Code) The party to be credited with funds.
CS	Consolidator Party consolidating various consignments, payments etc.
CW	Equipment owner Owner of equipment (container, etc.).
CX	Consignee's agent Party authorized to act on behalf of the consignee.
CZ	Consignor (3336) Party which, by contract with a carrier, consigns or sends goods with the carrier, or has them conveyed by him. Synonym: shipper, sender.
DBB	Debtor's bank (SWIFT Code) Identifies the account servicer for the debtor.

## Used Codes

---

DCS	Temporary employee A person employed on a temporary basis.
DCT	Designer A party who designs.
DCU	Quotation delivered to Party to whom the quotation is to be or has been delivered. EDIFACT
DCV	Developer A party who develops.
DCX	Party to receive refund Party to whom a refund is given.
DEF	Meat cutter Person whose job is to cut up and/or mince meat. EDIFACT
DEQ	Shipper Party responsible for the shipment of goods.
DER	Source data pool A data pool that supports the functionality required by a data source such as data loading, publication, notification, registration, etc.
DES	Brand owner The owner of a brand.
DFZ	Article information responsible party The party responsible for article information. GS1 Note: Replaces GS1 Temporary Code IPD.
DGA	Price information responsible party The party responsible for price information. GS1 Note: Replaces GS1 Temporary Code IPR.
DGB	Invoice processing party Party to whom the invoice is sent and who processes the invoice on behalf of the invoicee. Note, the invoicee is legally responsible for the invoice and can be different to the processing party. GS1 Note: Replaces GS1 Temporary Code ITO.
DGC	Logistic service provider A party providing logistic services for another party (e.g re-packing suppliers products) on products. GS1 Note: Replaces GS1 Temporary Code LSP.
DGD	Fattener Party which provides fattening services. GS1 Note: Replaces GS1 Temporary Code X51.

## Used Codes

---

DGE	Breeder Party which provides breeding. GS1 Note: Replaces GS1 Temporary Code X52.
DL	Factor Company offering a financial service whereby a firm sells or transfers title to its accounts receivable to the factoring company.
DM	Party to whom documents are to be presented Party to whom documents are to be presented.
DP	Delivery party (3144) Party to which goods should be delivered, if not identical with consignee. GS1 Description: Party to which goods should be delivered, if not the same as the buyer.
DS	Distributor Party distributing goods, financial payments or documents.
EM	Party to receive electronic memo of invoice Party being informed about invoice issue (via EDI).
EO	Owner of equipment Party who owns equipment.
EX	Exporter (3030) Party who makes - or on whose behalf a Customs clearing agent or other authorized person makes - an export declaration. This may include a manufacturer, seller or other person. Within a Customs union, consignor may have the same meaning as exporter.
FD	Buyer's parent company Parent company, e.g. holding company.
FP	Freight/charges payer Party responsible for the payment of freight.
FR	Message from Party where the message comes from.
FW	Freight forwarder Party arranging forwarding of goods.
GL	Socially insured person A person who is registered in a social security scheme.
GM	Inventory controller To specifically identify the party in charge of inventory control.
GO	Goods owner The party which owns the goods.

## Used Codes

---

GQ	Slaughterer Party or person who has undertaken or will undertake a slaughter.
GW	Party fulfilling all operations Code indicating the fact that the party identified carries out all operations within that company's activities.
GX	Central catalogue party Party controlling a central catalogue.
GY	Inventory reporting party Party reporting inventory information.
GZ	Substitute supplier Party which may be in a position to supply products or services should the main usual supplier be unable to do so.
HP	Final message recipient To identify the final recipient of the message.
HQ	Owner of account (SWIFT Code) Identifies the owner of the account.
HX	Debtor (SWIFT Code) Party from whom payment is due.
I1	Intermediary bank 1 A financial institution between the ordered bank and the beneficiary's bank.
I2	Intermediary bank 2 A financial institution between the ordered bank and the beneficiary's bank.
II	Issuer of invoice (3028) Party issuing an invoice.
IM	Importer (3020) Party who makes - or on whose behalf a Customs clearing agent or other authorized person makes - an import declaration. This may include a person who has possession of the goods or to whom the goods are consigned.
IN	Insurer A person or company offering insurance policies for premiums.
IPA	Party information party (GS1 Temporary Code) The party in a company who is responsible for the party information. The PARTIN message may be requested from or sent by this party.
IPD	Article information party (GS1 Temporary Code) The party in a company who is responsible for the pricing or other article information. The PRICAT or PRODAT messages may be requested from or sent by this party. GS1 Note: Code marked for deletion. Use value DFZ instead.

## Used Codes

IPR	<p>Price information party (GS1 Temporary Code)</p> <p>The party in a company who is responsible for the price information. The PRICAT message may be requested from or sent by this party.</p> <p>GS1 Note: Code marked for deletion. Use value DGA instead.</p>
ITO	<p>Invoice recipient party (GS1 Temporary Code)</p> <p>Party to whom the invoice is sent and who processes the invoice on behalf of the invoicee. Note, the invoicee is legally responsible for the invoice and can be different to the processing party.</p> <p>GS1 Note: Code marked for deletion. Use value DGB instead.</p>
IV	<p>Invoicee</p> <p>(3006) Party to whom an invoice is issued.</p>
JB	<p>Goods collection party</p> <p>Party that will collect or has collected the goods.</p> <p>GS1 Description: Party that will collect or has collected the goods.</p>
LC	<p>Party declaring the Value Added Tax (VAT)</p> <p>A code to identify the party who is responsible for declaring the Value Added Tax (VAT) on the sale of goods or services.</p>
LD	<p>Party recovering the Value Added Tax (VAT)</p> <p>A code to identify the party who is eligible to recover the Value Added Tax (VAT) on the sale of goods or services.</p>
LF	<p>Buyer's corporate office</p> <p>The identification of the buyer's corporate office.</p>
LG	<p>Supplier's corporate office</p> <p>The identification of the supplier's corporate office.</p>
LP	<p>Loading party</p> <p>Party responsible for the loading when other than carrier.</p>
LSP	<p>Logistic Service Provider (GS1 Temporary Code)</p> <p>A party providing logistic services for another party (e.g re-packing suppliers products) on products which may lead to added value for the product.</p> <p>GS1 Note: Code marked for deletion. Use value DGC instead.</p>
MA	<p>Party for whom item is ultimately intended</p> <p>Party for whom item is ultimately intended.</p>
MF	<p>Manufacturer of goods</p> <p>Party who manufactures the goods.</p>
MP	<p>Manufacturing plant</p> <p>Self explanatory.</p> <p>GS1 Description: Industrial department of a company in which goods are manufactured with appropriate equipment and fittings.</p>



## Used Codes

MR	Message recipient A party to receive a message or messages.
MS	Document/message issuer/sender Issuer of a document and/or sender of a message.
N1	Notify party no. 1 The first party which is to be notified.
N2	Notify party no. 2 The second party which is to be notified.
NFP	No function priority allocated (GS1 Temporary Code) Code indicating that the party identified is capable of carrying out all or most functions within the party.
NI	Notify party (3180) Party to be notified of arrival of goods.
OB	Ordered by Party who issued an order. GS1 Description: Party who issued an order for goods and services.
OR	Ordered bank Identifies the account servicer for the ordering customer or payor.
OS	Original shipper The original supplier of the goods.
OV	Owner of means of transport (3126) Party owning the means of transport. No synonym of carrier = CA.
OY	Ordering customer Identifies the originator of the instruction. GS1 Description: Only used in financial messages.
P1	Contact party 1 First party to contact.
P2	Contact party 2 Second party to contact.
PB	Paying financial institution Financial institution designated to make payment.
PE	Payee Identifies the credit party when other than the beneficiary.
PF	Party to receive freight bill Party to whom the freight bill should be sent.

## Used Codes

---

PL	Payor Identifies the debit party when other than the ordering customer (for banking purposes).
PO	Ordering party To be used only if ordering party and buyer are not identical.
PR	Payer (3308) Party initiating payment.
PW	Despatch party (3282) Party where goods are collected or taken over by the carrier (i.e. if other than consignor).
PX	Party to receive all documents A party which is named to be the recipient of all documents.
PY	Checking party Party or contact designated on behalf of carrier or his agent to establish the actual figures for quantities, weight, volume and/or (cube) measurements of goods or containers which are to appear in the transport contract and on which charges will be based.
RA	Central bank or regulatory authority Identifies central bank or regulatory authority which must be informed of certain aspects of a message.
RB	Receiving financial institution Financial institution designated to receive payment.
RE	Party to receive commercial invoice remittance Party to whom payment for a commercial invoice or bill should be remitted.
RH	Seller's financial institution Financial institution designated by seller to receive payment. RDFI (ACH transfers).
RV	Receiver of cheque Identifies the party which is to receive the actual cheque, when different from the receiver of funds.
SA	Sales person number (GS1 Temporary Code) The identification of a sales person number. GS1 Note: Code marked for deletion. Use value SE instead.
SE	Seller (3346) Party selling merchandise to a buyer. GS1 Note: Replaces GS1 Temporary Code SA.
SF	Ship from Identification of the party from where goods will be or have been shipped.

## Used Codes

---

SN	Store number A party keeping a shop or store. GS1 Description: Number allocated to identify a store.
SR	Supplier's agent/representative (3254) Party representing the seller for the purpose of the trade transaction. GS1 Description: Party representing the supplier for the purpose of the trade transaction.
SS	Social securities collector's office Party collecting social securities premiums.
ST	Ship to Identification of the party to where goods will be or have been shipped.
SU	Supplier Party who supplies goods and/or services. GS1 Description: Party which provides service(s) and/or manufactures or otherwise has possession of goods, and consigns or makes them available in trade.
TC	Tax collector's office Party collecting taxes.
TPE	Testing party (GS1 Temporary Code) A party authorized to carry out a specified test.
TS	Party to receive certified test results Party to whom the certified test results should be sent.
UC	Ultimate consignee Party who has been designated on the invoice or packing list as the final recipient of the stated merchandise.
UD	Ultimate customer The final recipient of goods.
WH	Warehouse keeper (3022) Party taking responsibility for goods entered into a warehouse.
WS	Wholesaler Seller of articles, often in large quantities, to be retailed by others.
X47	Cash register number (GS1 Temporary Code) Number allocated to identify a cash register.
X48	Corporate identity (GS1 Temporary Code) The identity of party to whom all other parties of the same commercial organisation are linked.

## Used Codes

---

X50	Mincing plant (GS1 Temporary Code) A place where the meat of animals is cut into very small pieces using a meat grinder. GS1 Note: Code marked for deletion.
X51	Fattener (GS1 Temporary Code) Party which fattens the animal. GS1 Note: Code marked for deletion. Use value DGD instead.
X52	Breeder (GS1 Temporary Code) Party which breeds the animal. GS1 Note: Code marked for deletion. Use value DGE instead.
X53	Content Owner (GS1 Temporary Code) Not available. GS1 Note: Code marked for deletion.
X54	Temperature variation (GS1 Temporary Code) Temperature variation upward or downward
X56	No / missing loading space (GS1 Temporary Code) The goods/consignment/equipment could not be loaded because of no/missing loading space.
ZZZ	Mutually defined Party specification mutually agreed between interchanging parties.

### 3045

Party name format code  
Code specifying the representation of a party name.

1	Name components in sequence as defined in description below Name component 1: Family name. Name component 2: Given name or initials. Name component 3: Given name or initials. Name component 4: Maiden name. Name component 5: Title Group of name components transmitted in sequence with name component 1 transmitted first. The maiden name is the family name given at birth of a female. Other names are self-explanatory.
---	---

### 3055

Code list responsible agency code  
Code specifying the agency responsible for a code list.

2	CEC (Commission of the European Communities) Generic: see also 140, 141, 142, 162. GS1 Description: Commission of the European Communities
3	IATA (International Air Transport Association) The airline industry's international organisation. GS1 Description: International Air Transport Association
5	ISO (International Organization for Standardization) International Organization of Standardization.

## Used Codes

6	UN/ECE (United Nations - Economic Commission for Europe) United Nations Economic Commission for Europe.
7	CEFIC (Conseil Europeen des Federations de l'Industrie Chimique) EDI project for chemical industry.
8	EDIFICE Standardised electronic commerce forum for companies with interests in computing, electronics and telecommunications. GS1 Description: EDI Forum for companies with Interest in Computing and Electronics (EDI project for EDP/ADP sector).
9	GS1 GS1 (formerly EAN International), an organisation of GS1 Member Organisations, which manages the GS1 System. GS1 Description: GS1 International.
10	ODETTE Organization for Data Exchange through Tele-Transmission in Europe (European automotive industry project).
17	S.W.I.F.T. Society for Worldwide Interbank Financial Telecommunications s.c.
28	EDITEUR (European book sector electronic data interchange group) Code identifying the pan European user group for the book industry as an organisation responsible for code values in the book industry.
60	Assigned by national trade agency The code list is from a national agency.
65	GS1 France Organisation responsible for GS1 System in France.
68	GS1 Italy Organisation responsible for GS1 System in Italy.
83	US, National Retail Federation The National Retail Federation is the trade association for the general merchandise retailing industry. In addition to providing support and education services, they also maintain and publish standard colour and size codes for the retail industry.
84	DE, BRD (Gesetzgeber der Bundesrepublik Deutschland) German legislature.
86	Assigned by party originating the message Codes assigned by the party originating the message.
87	Assigned by carrier Codes assigned by the carrier.

## Used Codes

---

88	Assigned by owner of operation Assigned by owner of operation (e.g. used in construction).
89	Assigned by distributor Codes assigned by a distributor.
90	Assigned by manufacturer Code assigned by the manufacturer.
91	Assigned by supplier or supplier's agent Codes assigned by a seller or seller's agent. GS1 Description: Code assigned by the supplier or supplier's agent.
92	Assigned by buyer or buyer's agent Codes assigned by a buyer or buyer's agent.
112	US, U.S. Census Bureau The Bureau of the Census of the U.S. Dept. of Commerce.
113	GS1 US Organisation responsible for GS1 System in the USA.
116	US, ANSI ASC X12 American National Standards Institute ASC X12.
131	DE, German Bankers Association German Bankers' Association.
136	GS1 UK Organisation responsible for GS1 System in the UK.
137	AT, Verband oesterreichischer Banken und Bankiers Austrian bankers association.
174	DE, DIN (Deutsches Institut fuer Normung) German standardization institute.
182	US, Standard Carrier Alpha Code (Motor) Organisation maintaining the SCAC lists and transportation operating in North America.
194	AU, AQIS (Australian Quarantine and Inspection Service) Australian Quarantine and Inspection Service.
200	GS1 Netherlands Organisation responsible for GS1 System in the Netherlands.
245	GS1 Denmark Organisation responsible for GS1 System in Denmark.

**Used Codes**

246	GS1 Germany Organisation responsible for GS1 System in Germany. GS1 Description: German representative of International Article Numbering association (GS1).
260	Ediel Nordic forum A code to identify Ediel Nordic forum, which is an organization standardizing the use of EDI between the participants in the Nordic power market.
281	GS1 Belgium & Luxembourg Organisation responsible for GS1 System in Belgium & Luxembourg.
286	SE, TCO (Tjänstemännens Central Organisation) The Swedish Confederation of Professional Employees.
294	GS1 Austria Organisation responsible for the GS1 System in Austria.
295	AU, Therapeutic Goods Administration Austrian administration responsible for the regulation of therapeutic goods in Australia. EDIFACT
297	IT, Ufficio IVA Ufficio responsabile gestione partite IVA, Italy (Italian Institute issuing VAT registration numbers). EDIFACT
298	GS1 Spain Organisation responsible for the GS1 System in Spain.
316	GS1 Finland Organisation responsible for the GS1 system in Finland.
317	GS1 Brazil Organisation responsible for the GS1 system in Brazil.
324	GS1 Ireland Organisation responsible for the GS1 system in Ireland.
325	GS1 Russia Organisation responsible for the GS1 system in Russia.
326	GS1 Poland Organisation responsible for the GS1 system in Poland.
327	GS1 Estonia Organisation responsible for the GS1 system in Estonia.
376	PANTONE Color code controlling organisation
400	FAO (Food and Agriculture Organisation) Food and Agriculture Organisation of the United Nations.

## Used Codes

---

403	Comite European de Normalisation Comite Européen de Normalisation (CEN), European committee for standardisation. GS1 Note: Replaces GS1 Temporary Code CEN.
404	Assigned by logistics service provider Codes assigned by a logistics service provider. GS1 Note: Replaces GS1 Temporary Code X6.
CEN	Comite European de Normalisation (GS1 Temporary Code) Comite European de Normalisation. GS1 Note: Code marked for deletion. Use value 403 instead.
PMS	Pantone Matching System (GS1 Temporary Code) Pantone Matching System.
RAL	DE, Deutsches Institut fuer Guetesicherung und Kennzeichnung (GS1 Temporary Code) German Institute for Quality Assurance and Certification.
X5	IT, Ufficio IVA (GS1 Temporary Code) Ufficio responsabile gestione partite IVA, Italy (Italian Institute issuing VAT registration numbers).
X6	Assigned by logistics service provider (GS1 Temporary Code) Codes assigned by the logistics service provider. GS1 Note: Code marked for deletion. Use value 404 instead.
ZZZ	Mutually defined A code assigned within a code list to be used on an interim basis and as defined among trading partners until a precise code can be assigned to the code list.
<b>3207</b>	Country name code   Identification of the name of the country or other geographical entity as defined in ISO 3166-1.  Notes:   1. Use ISO 3166-1 two alpha country code.
AD	Andorra
AE	United Arab Emirates
AF	Afghanistan
AG	Antigua and Barbuda
AI	Anguilla
AL	Albania
AM	Armenia
AO	Angola



**Used Codes**

AQ	Antarctica
AR	Argentina
AS	American Samoa
AT	Austria
AU	Australia
AW	Aruba
AX	Åland Islands
AZ	Azerbaijan
BA	Bosnia and Herzegovina
BB	Barbados
BD	Bangladesh
BE	Belgium
BF	Burkina Faso
BG	Bulgaria
BH	Bahrain
BI	Burundi
BJ	Benin
BL	Saint Barthélemy
BM	Bermuda
BN	Brunei Darussalam
BO	Bolivia (Plurinational State of)
BQ	Bonaire, Sint Eustatius and Saba
BR	Brazil
BS	Bahamas
BT	Bhutan
BV	Bouvet Island
BW	Botswana
BY	Belarus
BZ	Belize
CA	Canada
CC	Cocos (Keeling) Islands
CD	Congo, Democratic Republic of
CF	Central African Republic

**Used Codes**

CG	Congo
CH	Switzerland
CI	Cote D'Ivoire
CK	Cook Islands
CL	Chile
CM	Cameroon
CN	China
CO	Colombia
CR	Costa Rica
CU	Cuba
CV	Cape Verde
CW	Curaçao
CX	Christmas Island
CY	Cyprus
CZ	Czechia
DE	Germany
DJ	Djibouti
DK	Denmark
DM	Dominica
DO	Dominican Republic
DZ	Algeria
EC	Ecuador
EE	Estonia
EG	Egypt
EH	Western Sahara
ER	Eritrea
ES	Spain
ET	Ethiopia
FI	Finland
FJ	Fiji
FK	Falkland Islands (Malvinas)
FM	Micronesia (Federated States of)
FO	Faroe Islands

**Used Codes**

FR	France
GA	Gabon
GB	United Kingdom of Great Britain and Northern Ireland
GD	Grenada
GE	Georgia
GF	French Guiana
GG	Guernsey
GH	Ghana
GI	Gibraltar
GL	Greenland
GM	Gambia
GN	Guinea
GP	Guadeloupe
GQ	Equatorial Guinea
GR	Greece
GS	South Georgia and the South Sandwich Islands
GT	Guatemala
GU	Guam
GW	Guinea-Bissau
GY	Guyana
HK	Hong Kong
HM	Heard Island and McDonald Islands
HN	Honduras
HR	Croatia
HT	Haiti
HU	Hungary
ID	Indonesia
IE	Ireland
IL	Israel
IM	Isle Of Man
IN	India
IO	British Indian Ocean Territory
IQ	Iraq

**Used Codes**

IR	Iran (Islamic Republic of)
IS	Iceland
IT	Italy
JE	Jersey
JM	Jamaica
JO	Jordan
JP	Japan
KE	Kenya
KG	Kyrgyzstan
KH	Cambodia
KI	Kiribati
KM	Comoros
KN	Saint Kitts and Nevis
KP	Korea (Democratic People'S Republic of)
KR	Korea, Republic of
KW	Kuwait
KY	Cayman Islands
KZ	Kazakhstan
LA	Lao People'S Democratic Republic
LB	Lebanon
LC	Saint Lucia
LI	Liechtenstein
LK	Sri Lanka
LR	Liberia
LS	Lesotho
LT	Lithuania
LU	Luxembourg
LV	Latvia
LY	Libya
MA	Morocco
MC	Monaco
MD	Moldova, Republic of
ME	Montenegro

**Used Codes**

MF	Saint Martin (French Part)
MG	Madagascar
MH	Marshall Islands
MK	Macedonia, the Former Yugoslav Republic of
ML	Mali
MM	Myanmar
MN	Mongolia
MO	Macao
MP	Northern Mariana Islands
MQ	Martinique
MR	Mauritania
MS	Montserrat
MT	Malta
MU	Mauritius
MV	Maldives
MW	Malawi
MX	Mexico
MY	Malaysia
MZ	Mozambique
NA	Namibia
NC	New Caledonia
NE	Niger
NF	Norfolk Island
NG	Nigeria
NI	Nicaragua
NL	Netherlands
NO	Norway
NP	Nepal
NR	Nauru
NU	Niue
NZ	New Zealand
OM	Oman
PA	Panama

**Used Codes**

---

PE	Peru
PF	French Polynesia
PG	Papua New Guinea
PH	Philippines
PK	Pakistan
PL	Poland
PM	Saint Pierre and Miquelon
PN	Pitcairn
PR	Puerto Rico
PS	Palestine, State of
PT	Portugal
PW	Palau
PY	Paraguay
QA	Qatar
RE	Reunion
RO	Romania
RS	Serbia
RU	Russian Federation
RW	Rwanda
SA	Saudi Arabia
SB	Solomon Islands
SC	Seychelles
SD	Sudan
SE	Sweden
SG	Singapore
SH	Saint Helena, Ascension and Tristan da Cunha
SI	Slovenia
SJ	Svalbard and Jan Mayen
SK	Slovakia
SL	Sierra Leone
SM	San Marino
SN	Senegal
SO	Somalia

**Used Codes**

SR	Suriname
SS	South Sudan
ST	Sao Tome and Principe
SV	El Salvador
SX	Sint Maarten (Dutch part)
SY	Syrian Arab Republic
SZ	Swaziland
TC	Turks and Caicos Islands
TD	Chad
TF	French Southern Territories
TG	Togo
TH	Thailand
TJ	Tajikistan
TK	Tokelau
TL	Timor-Leste
TM	Turkmenistan
TN	Tunisia
TO	Tonga
TR	Turkey
TT	Trinidad and Tobago
TV	Tuvalu
TW	Taiwan, Province of China
TZ	Tanzania, United Republic of
UA	Ukraine
UG	Uganda
UM	United States Minor Outlying Islands
US	United States of America
UY	Uruguay
UZ	Uzbekistan
VA	Holy See
VC	Saint Vincent and the Grenadines
VE	Venezuela (Bolivarian Republic of)
VG	Virgin Islands, British

## Used Codes

VI	Virgin Islands, U.S.
VN	Viet Nam
VU	Vanuatu
WF	Wallis and Futuna
WS	Samoa
YE	Yemen
YT	Mayotte
ZA	South Africa
ZM	Zambia
ZW	Zimbabwe
<b>3227</b>	Location function code qualifier Code identifying the function of a location.
1	Place of terms of delivery (3018) Point or port of departure, shipment or destination, as required under the applicable terms of delivery, e.g. Incoterms.
2	Payment place Place where funds are to be, or have been made available to the creditor.
5	Place of departure (3214) Port, airport or other location from which a means of transport or transport equipment is scheduled to depart or has departed.
7	Place of delivery (3246) Place to which the goods are to be finally delivered under transport contract terms (operational term).
8	Place of destination Port, airport or other location to which a means of transport or transport equipment is destined.
9	Place/port of loading (3334 + 3230) Seaport, airport, freight terminal, rail station or other place at which the goods (cargo) are loaded on to the means of transport being used for their carriage.
10	Place of acceptance (3348) Place at which the goods are taken over by the carrier.
11	Place/port of discharge (3392 + 3414) Seaport, airport, freight terminal, rail station or other place at which the goods (cargo) are unloaded from the means of transport having been used for their carriage.



## Used Codes

---

13	Place of transhipment (3424) Place where goods are transferred from one means of transport to another (operational term).
14	Location of goods (3384) Place where goods are located and where they are available for examination.
17	Border crossing place Place where goods are transported across a country border.
18	Warehouse (3156) Warehouse where a particular consignment has been stored.
19	Factory/plant Factory/plant relevant for a particular consignment.
22	Customs office of clearance (3080) Place where Customs clearance procedure occur (CCC).
24	Port of entry Port where final documentation is filed for Customs Entry processing.
27	Country of origin [3238] Country in which the goods have been produced or manufactured, according to criteria laid down for the purposes of application of the Customs tariff, of quantitative restrictions, or of any other measure related to trade.
28	Country of destination of goods Country to which the goods are to be delivered.
30	Country of source Country in which raw material or components were originally produced prior to manufacture or assembly in another country.
33	Baseport of discharge The port of discharge according to the tariff as opposed to the operational port of discharge. The goods may or may not be actually discharged at that port on the main transport.
34	Baseport of loading The port of loading according to the tariff as opposed to the operational port of loading. The goods may or may not be actually loaded at that port on the main transport.
35	Country of exportation/despatch (3220) Country from which the goods were initially exported to the importing country without any commercial transaction taking place in intermediate countries. Syn.: country whence consigned. Country of despatch: country from which goods are despatched between countries of a Customs union.
36	Country of ultimate destination (3216) Country known to the consignor or his agent at the time of despatch to be the final country to which the goods are to be delivered.

**Used Codes**

37	Country of last consignment [3331] Country where the goods are loaded onto the means of transport used for their importation.
38	Country of first destination [3219] Country where the goods are offloaded from the means of transport used for their exportation.
39	Country of production Country where item has been or will be produced.
40	Country of trading Country where item has been or will be traded.
42	Customs office of exit [3096] Customs office at which the goods leave the country of dispatch/export.
45	Customs office of destination (transit) (3086) Customs office at which a transit operation is terminated. Synonym: Customs office of transit termination.
47	Region of destination Region known to the consignor or his agent at the time of despatch to be the final region to which the goods are to be delivered.
53	Charge and freight due from Place or point from which charges and freight are charged.
55	Charges and freight payable to [3274] Name of place up to which freight charges and other charges are to be paid.
57	Place of payment Name of the location at which freight and charges for main transport are payable.
60	Place of arrival Place at which the transport means arrives.
80	Place of despatch Place at which the goods are taken over for carriage (operational term), if different from the transport contract place of acceptance (see: 10). Synonym: Place of origin of carriage.
82	Pre-carriage port Port of loading at which the cargo is loaded on the pre-carriage vessel used for the transport prior to the main transport.
83	Place of delivery (by on-carriage) Place to which the goods are to be finally delivered.
88	Place of receipt Identification of the location at which the cargo is actually received.

## Used Codes

---

92	Routing Indication of a routing place.
106	Region of origin Region in which the goods have been produced or manufactured according to the criteria laid down for the purposes of the application of the Customs tariff, of quantitative restrictions or of any other measures related to trade (see: 3238).
121	Country of sale [3116] Country where exporter's co-contractor is domiciled or has his business.
159	Additional internal destination Any location within the consignee's premises where the goods are moved to.
162	Place or location of sale Place or location at which the sale takes place.
184	Physical location Identifies the physical location.
241	Country of birth Country where a person or an animal was born.
242	Country of fattening Country where an animal has been fattened.
243	Country of slaughter Country where an animal has been slaughtered.
244	Country of meat cutting Country where the meat is cut into pieces. Country where an animal's carcass has been cut into smaller pieces.
245	Meat cutting location A location where the meat is cut into pieces. EDIFACT
246	Slaughterhouse Place for the slaughter of animals as food.
247	Country of meat mincing Country where meat has been cut into very small pieces using a meat grinder.
256	Place of packing Place where goods are packaged. EDIFACT
257	Country of assembly Country where product is assembled. Uses ISO country codes.

## Used Codes

298	Country of last processing The country where the trade item was last processed.
299	Fishing vessel Fishing vessel as a place of production
300	Location of status The identification of the location of a status. GS1 Note: Replaces GS1 Temporary Code 16E.
301	Location of meter The identification of the location of a meter. GS1 Note: Replaces GS1 Temporary Code 17E.
303	Meat mincing plant A place where the meat is cut into very small pieces using a meat grinder. GS1 Note: Replaces GS1 Temporary Code 41E.
304	Place of fattening Place where an animal has been fattened. GS1 Note: Replaces GS1 Temporary Code 42E.
305	Animal birth place Location where an animal was born. GS1 Note: Replaces GS1 Temporary Code 43E.
306	Global Good Agricultural Practice Number (GGN) The Global Good Agricultural Practice Number (GGN) is a 13-digit number that uniquely identifies each producer and individual member of a producer group in the GLOBAL G.A.P. Database.
16E	Location of status (GS1 Temporary Code) Identification of the location of a status. GS1 Note: Code marked for deletion. Use value 300 instead.
17E	Location of meter (GS1 Temporary Code) The identification of the location of a meter. GS1 Note: Code marked for deletion. Use value 301 instead.
18E	Country of provenance (GS1 Temporary Code) The country of provenance of a consignment or product.
21E	Testing location (GS1 Temporary Code) The location where a test is being performed.
22E	Movement to location (GS1 Temporary Code) Identification of the location to where goods are to be moved.
23E	Return location (GS1 Temporary Code) The identification of a location for the return of goods.

## Used Codes

---

41E	Mincing plant (GS1 Temporary Code) A place where the meat of animals is cut into very small pieces using a meat grinder. GS1 Note: Code marked for deletion. Use value 303 instead.
42E	Place of fattening (GS1 Temporary Code) Place where the animal has been fattened before killing for food. GS1 Note: Code marked for deletion. Use value 304 instead.
43E	Animal's Birth Place (GS1 Temporary Code) Place/Location where an animal was born (GLN or Veterinary licence number) GS1 Note: Code marked for deletion. Use value 305 instead.
<b>3233</b>	Second related location name code Code specifying the second related location.  Notes: 1. Recommend use UN/ECE Recommendation No. 16: UN/LOCODE. If not applicable, use appropriate code set in combination with 1131/3055.
LONDEC	Longitude DEC (GS1 Permanent Code) Longitude of a location expressed in decimal degree (DDD.dddd) + E or W.
LONDMS	Longitude DMS (GS1 Permanent Code) Longitude of a location expressed in degree, minute & second (DDMMSS) + E or W.
<b>3279</b>	Geographic area code Code specifying a geographical area.
DO	Domestic Domestic message as defined by relevant central bank.
DR	Domestic with regulatory information required Domestic message with requirement to regulatory information to central bank.
IN	International International message as defined by relevant central bank.
IR	International with regulatory information required International message with requirement to regulatory information to central bank.
YC4	European (SWIFT Code) European message.
<b>3285</b>	Instruction receiving party identifier Code specifying the party to receive an instruction.

## Used Codes

---

4	Beneficiary The party in whose favour the documentary credit is to be issued and the party who must comply with the credit's terms and conditions.
5	Contact party 1 First party to contact.
11	Creditor Party to whom payment is due. EDIFACT
12	Receiving bank Identifies the bank which is to receive funds. GS1 Description: Recipient of the instruction identification.
13	Creditor's bank Identifies the bank to whom payment is due. EDIFACT
15	Debtor Party from whom payment is due.
CRB	Creditor's bank (SWIFT Code) Identifies the account servicer for the creditor.
CRE	Creditor (SWIFT Code) The party to be credited with funds.
YC5	Ordered bank (SWIFT Code) The financial institution which is instructed by the ordering party to act on the transaction.
YC6	Payee (SWIFT Code) Identifies the credit party when other than the beneficiary.
<b>3301</b>	Enacting party identifier To identify the party enacting an instruction.
3	Beneficiary's bank The financial institution with which the beneficiary maintains an account.
4	Buyer The buyer is responsible for carrying out the instruction.
5	Seller The seller is responsible for carrying out the instruction.
8	Debtor's bank Identifies the bank from whom payment is due.

**Used Codes**

9	Ordered bank The financial institution with which the ordering party maintains an account. The financial institution with which the ordering party maintains an account.
CRB	Creditor's bank (SWIFT Code) Identifies the account servicer for the creditor.
YC7	Ordered bank (SWIFT Code) The financial institution which is instructed by the ordering party to act on the transaction.
<b>3433</b>	Institution name code Code specifying the name of an institution.
BK	Bank (GS1 Permanent Code) The financial institution being identified is a bank.
PO	Post office (GS1 Permanent Code) The financial institution being identified is a post office.
<b>3453</b>	Language name code Code specifying the language name.  Notes: 1. Use ISO 639-1988.
AA	Afar
aa	Afar
AB	Abkhazian
ab	Abkhazian
AE	Avestan
ae	Avestan
AF	Afrikaans
af	Afrikaans
AK	Akan
ak	Akan
AM	Amharic
am	Amharic
AN	Aragonese
an	Aragonese
AR	Arabic
ar	Arabic

**Used Codes**

AS	Assamese
as	Assamese
AV	Avaric
av	Avaric
AY	Aymara
ay	Aymara
AZ	Azerbaijani
az	Azerbaijani
BA	Bashkir
ba	Bashkir
BE	Belarusian
be	Belarusian
BG	Bulgarian
bg	Bulgarian
BH	Bihari
bh	Bihari
BI	Bislama
bi	Bislama
BM	Bambara
bm	Bambara
BN	Bengali
bn	Bengali
BO	Tibetan
bo	Tibetan
BR	Breton
br	Breton
BS	Bosnian
bs	Bosnian
CA	Catalan; Valencian
ca	Catalan; Valencian
CE	Chechen
ce	Chechen
CH	Chamorro



**Used Codes**

ch	Chamorro
CO	Corsican
co	Corsican
CR	Cree
cr	Cree
CS	Czech
cs	Czech
CU	Church Slavonic; Old Slavonic; Church Slavonic; Old Bulgarian; Old Church Slavonic
cu	Church Slavonic; Old Slavonic; Church Slavonic; Old Bulgarian; Old Church Slavonic
CV	Chuvash
cv	Chuvash
CY	Welsh
cy	Welsh
DA	Danish
da	Danish
DE	German
de	German
DV	Divehi; Dhivehi; Maldivian
dv	Divehi; Dhivehi; Maldivian
DZ	Dzongkha
dz	Dzongkha
EE	Ewe
ee	Ewe
EL	Greek; Modern (1453-)
el	Greek; Modern (1453-)
EN	English
en	English
EO	Esperanto
eo	Esperanto
ES	Spanish; Castilian
es	Spanish; Castilian
ET	Estonian

**Used Codes**

et	Estonian
EU	Basque
eu	Basque
FA	Persian
fa	Persian
FF	Fulah
ff	Fulah
FI	Finnish
fi	Finnish
FJ	Fijian
fj	Fijian
FO	Faroese
fo	Faroese
FR	French
fr	French
FY	Western Frisian
fy	Western Frisian
GA	Irish
ga	Irish
GD	Gaelic; Scottish Gaelic
gd	Gaelic; Scottish Gaelic
GL	Galician
gl	Galician
GN	Guarani
gn	Guarani
GU	Gujarati
gu	Gujarati
GV	Manx
gv	Manx
HA	Hausa
ha	Hausa
HE	Hebrew
he	Hebrew

**Used Codes**

HI	Hindi
hi	Hindi
HO	Hiri Motu
ho	Hiri Motu
HR	Croatian
hr	Croatian
HT	Haitian; Haitian Creole
ht	Haitian; Haitian Creole
HU	Hungarian
hu	Hungarian
HY	Armenian
hy	Armenian
HZ	Herero
hz	Herero
IA	Interlingua (International Auxiliary Language Association)
ia	Interlingua (International Auxiliary Language Association)
ID	Indonesian
id	Indonesian
IE	Interlingue
ie	Interlingue
IG	Igbo
ig	Igbo
II	Sichuan Yi
ii	Sichuan Yi
IK	Inupiaq
ik	Inupiaq
IO	Ido
io	Ido
IS	Icelandic
is	Icelandic
IT	Italian
it	Italian
IU	Inuktitut

**Used Codes**

iu	Inuktitut
JA	Japanese
ja	Japanese
JV	Javanese
jv	Javanese
KA	Georgian
ka	Georgian
KG	Kongo
kg	Kongo
KI	Kikuyu; Gikuyu
ki	Kikuyu; Gikuyu
KJ	Kuanyama; Kwanyama
kj	Kuanyama; Kwanyama
KK	Kazakh
kk	Kazakh
KL	Kalaallisut; Greenlandic
kl	Kalaallisut; Greenlandic
KM	Central Khmer
km	Central Khmer
KN	Kannada
kn	Kannada
KO	Korean
ko	Korean
KR	Kanuri
kr	Kanuri
KS	Kashmiri
ks	Kashmiri
KU	Kurdish
ku	Kurdish
KV	Komi
kv	Komi
KW	Cornish
kw	Cornish

**Used Codes**

KY	Kirghiz; Kyrgyz
ky	Kirghiz; Kyrgyz
LA	Latin
la	Latin
LB	Luxembourgish; Letzeburgesch
lb	Luxembourgish; Letzeburgesch
LG	Ganda
lg	Ganda
LI	Limburgan; Limburger; Limburgish
li	Limburgan; Limburger; Limburgish
LN	Lingala
ln	Lingala
LO	Lao
lo	Lao
LT	Lithuanian
lt	Lithuanian
LU	Luba-Katanga
lu	Luba-Katanga
LV	Latvian
lv	Latvian
MG	Malagasy
mg	Malagasy
MH	Marshallese
mh	Marshallese
MI	Maori
mi	Maori
MK	Macedonian
mk	Macedonian
ML	Malayalam
ml	Malayalam
MN	Mongolian
mn	Mongolian
MO	Moldavian; Moldovan

**Used Codes**

mo	Moldavian; Moldovan
MR	Marathi
mr	Marathi
MS	Malay
ms	Malay
MT	Maltese
mt	Maltese
MY	Burmese
my	Burmese
NA	Nauru
na	Nauru
NB	Bokmal Norwegian; Norwegian Bokmal
nb	Bokmal Norwegian; Norwegian Bokmal
ND	Ndebele; North; North Ndebele
nd	Ndebele; North; North Ndebele
NE	Nepali
ne	Nepali
NG	Ndonga
ng	Ndonga
NL	Dutch; Flemish
nl	Dutch; Flemish
NN	Norwegian Nynorsk; Nynorsk, Norwegian
nn	Norwegian Nynorsk; Nynorsk, Norwegian
NO	Norwegian
no	Norwegian
NR	Ndebele; South; South Ndebele
nr	Ndebele; South; South Ndebele
NV	Navajo; Navaho
nv	Navajo; Navaho
NY	Chichewa; Chewa; Nyanja
ny	Chichewa; Chewa; Nyanja
OC	Occitan (post 1500); Provencal
oc	Occitan (post 1500); Provencal

**Used Codes**

OJ	Ojibwa
oj	Ojibwa
OM	Oromo
om	Oromo
OR	Oriya
or	Oriya
OS	Ossetian; Ossetic
os	Ossetian; Ossetic
PA	Panjabi; Punjabi
pa	Panjabi; Punjabi
PI	Pali
pi	Pali
PL	Polish
pl	Polish
PS	Pushto; Pashto
ps	Pushto; Pashto
PT	Portuguese
pt	Portuguese
QU	Quechua
qu	Quechua
RM	Romansh
rm	Romansh
RN	Rundi
rn	Rundi
RO	Romanian
ro	Romanian
RU	Russian
ru	Russian
RW	Kinyarwanda
rw	Kinyarwanda
SA	Sanskrit
sa	Sanskrit
SC	Sardinian

**Used Codes**

sc	Sardinian
SD	Sindhi
sd	Sindhi
SE	Northern Sami
se	Northern Sami
SG	Sango
sg	Sango
SI	Sinhala; Sinhalese
si	Sinhala; Sinhalese
SK	Slovak
sk	Slovak
SL	Slovenian
sl	Slovenian
SM	Samoan
sm	Samoan
SN	Shona
sn	Shona
SO	Somali
so	Somali
SQ	Albanian
sq	Albanian
SR	Serbian
sr	Serbian
SS	Swati
ss	Swati
ST	Sotho, Southern
st	Sotho, Southern
SU	Sundanese
su	Sundanese
SV	Swedish
sv	Swedish
SW	Swahili
sw	Swahili



**Used Codes**

TA	Tamil
ta	Tamil
TE	Telugu
te	Telugu
TG	Tajik
tg	Tajik
TH	Thai
th	Thai
TI	Tigrinya
ti	Tigrinya
TK	Turkmen
tk	Turkmen
TL	Tagalog
tl	Tagalog
TN	Tswana
tn	Tswana
TO	Tonga (Tonga Islands)
to	Tonga (Tonga Islands)
TR	Turkish
tr	Turkish
TS	Tsonga
ts	Tsonga
TT	Tatar
tt	Tatar
TW	Twi
tw	Twi
TY	Tahitian
ty	Tahitian
UG	Uighur; Uyghur
ug	Uighur; Uyghur
UK	Ukrainian
uk	Ukrainian
UR	Urdu

**Used Codes**

ur	Urdu
UZ	Uzbek
uz	Uzbek
VE	Venda
ve	Venda
VI	Vietnamese
vi	Vietnamese
VO	Volapük
vo	Volapük
WA	Walloon
wa	Walloon
WO	Wolof
wo	Wolof
XH	Xhosa
xh	Xhosa
YI	Yiddish
yi	Yiddish
YO	Yoruba
yo	Yoruba
ZA	Zhuang; Chuang
za	Zhuang; Chuang
ZH	Chinese
zh	Chinese
ZU	Zulu
zu	Zulu

**4025**

Business function code  
Code describing the specific business function.

AAN

Business expenses  
The reason for the transaction is business expenses.

AAO

Company social loan payment to bank  
Payment made by a company to a bank for financing social loans to the employees.

ADV

Advance payment  
The reason for payment is advance payment.

**Used Codes**

AMY	Alimony Payment on alimony.
BEN	Unemployment/disability/benefit Payment to person unemployed/disabled.
BON	Bonus The reason the transaction is bonus.
CAS	Cash management transfer Reason for the transaction is cash management transfer.
CBF	Capital building fringe fortune Capital building for retirement.
COC	Commercial credit Reason for payment is commercial credit.
COM	Commission Payment of commission. GS1 Description: Reason for payment is commission.
COS	Costs Reason for payments is costs.
CPY	Copyright Reason for payment is copyright.
DIV	Dividend payment Reason for payment is dividend.
FEX	Foreign exchange Reason for transaction is foreign exchange.
GDS	Purchase and sale of goods Purchasing and selling of goods. GS1 Description: Reason for transaction is purchase and sale of goods.
INS	Insurance premium Reason for transaction is insurance premium.
INT	Interest Payment of interest. GS1 Description: Reason for transaction is interest.
LIF	Licence fees Payment of licence fees. GS1 Description: Reason for transaction is licence fee.

**Used Codes**

LOA	Loan Transfer of loan to borrower.
LOR	Loan repayment Repayment of loan to lender.
NET	Netting Reason for transaction is netting.
PEN	Pension Payment of pension. GS1 Description: Reason for transaction is pension.
REN	Rent Reason for transaction is rent.
ROY	Royalties Payment of royalties. GS1 Description: Reason for transaction is royalties.
SAL	Salary Reason for payment is salary.
SCV	Purchase and sale of services Purchasing and selling of services. GS1 Description: Reason for transaction is purchase and sale of services.
SSB	Social security benefit Payment made by government to support individuals.
SUB	Subscription Reason for transaction is subscription.
TAX	Tax payment Payment of tax. GS1 Description: Reason for transaction is tax.
VAT	Value added tax payment Payment of Value Added Tax (VAT). GS1 Description: Reason for transaction is VAT.
VP	Voluntary pension (GS1 Temporary Code) Voluntary contributions.
<b>4027</b>	Business function type code qualifier Code qualifying the type of business function.

## Used Codes

---

1	Underlying business function The types of business.
<b>4343</b>	Response type code Code specifying the type of acknowledgment required or transmitted.
AA	Debit advice Receiver of the payment message needs to return a debit advice in response to the payment message.
AB	Message acknowledgement Indicates that an acknowledgement relating to receipt of message is required.
AC	Acknowledge - with detail and change Acknowledge complete including changes.
AI	Acknowledge only changes Acknowledgement of changes only is required.
AJ	Pending Indication that the referenced offer or transaction (e.g. cargo booking or quotation request) is being dealt with. EDIFACT
AP	Accepted Indication that the referenced offer or transaction (e.g., cargo booking or quotation request) has been accepted.
AS	Credit advice and message acknowledgement The receiver of the message is to acknowledge receipt of the message and sent a credit advice for each credit.
CA	Conditionally accepted Indication that the referenced offer or transaction (e.g., cargo booking or quotation request) has been accepted under conditions indicated in this message.
NA	No acknowledgement needed Specifies that no acknowledgement is needed in response to this message.
RE	Rejected Indication that the referenced offer or transaction (e.g., cargo booking or quotation request) is not accepted.
YW7	Credit advice (SWIFT Code) Receiver of the payment message needs to return a credit advice in response to the payment message.
<b>4347</b>	Product identifier code qualifier Code qualifying the product identifier.

## Used Codes

---

5	Product identification The item number is for product identification.
<b>4383</b>	Bank operation code Code specifying a bank operation.
ABX	Automated bills of exchange The payment has been done by automated bills of exchange.
BEX	Bills of exchange The payment has been done by bills of exchange.
BGI	Bankgiro The payment was originally made by bankgiro.
BKD	Bank draft Original payment was made by bank draft.
BKI	Bank initiated The fund transfer is initiated by a bank. GS1 Description: Payment was initiated by a bank.
CAL	Cash letter The payment has been done by a cash letter.
CHG	Charges The fund transfer represents charges. GS1 Description: The financial operation relates to charges.
CHI	Cheque international The financial operation has been done by international cheque.
CHN	Cheque national The financial operation has been done by national cheque.
CLR	Clearing The financial operation has been done by a clearing system.
COL	Collection The financial operation is collection.
COM	Commission The fund transfer represents commission.
CON	Cash concentration An aggregation of funds from different accounts into a single account.
CPP	Cash payment by post The financial operation has been done by cash payment by post.

## Used Codes

---

CUX	Currencies Buying or selling of foreign notes.
DDT	Direct debit The financial operation is direct debit.
DEP	Deposit cash operation The financial operation is by deposit cash.
FEX	Foreign exchange The financial operation is by foreign exchange.
FGI	Free format giro [Cyme] GS1 Description: The financial operation is a free format giro.
INT	Interest The fund transfer represents usury. GS1 Description: The financial operation is interest.
LOC	Letter of credit The financial operation is a letter of credit.
LOK	Lockbox Type of cash management system offered by financial institutions to provide for collection of customers 'receivables'.
MSC	Miscellaneous The fund transfer is miscellaneous. GS1 Description: The financial operation is miscellaneous.
PAC	Payment card Relating to credit, debit, guarantee or charge card.
PGI	Postgiro The financial operation has been done by postgiro.
POS	Point of sale The financial operation is point of sale. GS1 Description: The financial operation is at point of sale.
REC	Returned cheques The fund transfer represents returned cheques. GS1 Description: The financial operation is returned cheques.
RET	Returned items The fund transfer represents returned items. GS1 Description: The financial operation is returned items.

## Used Codes

---

RGI	Reference giro Payments was done by a special service, for low priority payments. Finnish national bank service.
RTR	Returned transfers The financial operation has been done by returned transfers.
SEC	Securities The fund transfer represents securities. GS1 Description: The financial operation is securities.
STO	Standing order The financial operation is done by a standing order.
TCK	Travellers cheque The financial operation is done by travellers cheque.
TRF	Transfer The financial operation is done by transfer.
UGI	Urgent giro Payment was made by special bank service, for high priority payments. Finnish national bank service.
VDA	Value date adjustment The financial operation has adjusted value date.
WDL	Withdrawal cash operation The financial operation is a withdrawal cash operation.
ZZZ	Mutually defined A temporary code which may be used between trading partners to describe a fund transfer whilst approval for a formal code value is being sought. GS1 Description: The financial operation is mutually defined.
<b>4401</b>	Instruction description code Code specifying an instruction.
1E	Return using only authorized transport (GS1 Temporary Code) The identified product is to be returned only using the identified authorised transport. GS1 Note: Code marked for deletion. Use value CQ instead.
2E	Return using any transport (GS1 Temporary Code) The identified product is to be returned using any transport. GS1 Note: Code marked for deletion. Use value CR instead.
3E	Return by specified date (GS1 Temporary Code) The identified product is to be returned by the date specified. GS1 Note: Code marked for deletion. Use value CT instead.



**Used Codes**

4E	Supplier to organise transport (GS1 Temporary Code) The supplier is to organise transport for the goods being returned. GS1 Note: Code marked for deletion. Use value CU instead.
5E	Buyer to organise transport (GS1 Temporary Code) The buyer is to organise transport for the goods being returned. GS1 Note: Code marked for deletion. Use value CV instead.
6E	Supplier to pay for transport (GS1 Temporary Code) The supplier is to pay for transport to be used to return goods.
7E	Buyer to pay for transport (GS1 Temporary Code) The buyer is to pay for transport to be used to return goods.
8E	Prepare for collection (GS1 Temporary Code) The goods for return are to be prepared for collection. GS1 Note: Code marked for deletion. Use value CW instead.
9E	Prepare for collection on specified date (GS1 Temporary Code) The goods for return are to be prepared for collection on the specified date. GS1 Note: Code marked for deletion. Use value CX instead.
AA	Send credit note Send a credit note. GS1 Description: Instruction to send a credit note.
AAE	Send debit note (GS1 Temporary Code) Instruction to send a debit note.
AD	Advise Instruction to advise a party.
AG	Send replacement The identified item must be sent for replacement.
AJ	Advise by fax (SWIFT Code) Instruction to advise party by fax.
AP	Advise by phone Instruction to advise party by phone.
AT	Advise by telex Instruction to advise party by telex.
CQ	Return using only authorized transport The item is to be returned only using the identified authorized transport. GS1 Note: Replaces GS1 Temporary Code 1E.
CR	Return using any transport The item may be returned using any transport. GS1 Note: Replaces GS1 Temporary Code 2E.

## Used Codes

---

CT	Return by specified date The item is to be returned by the date specified. GS1 Note: Replaces GS1 Temporary Code 3E.
CU	Supplier to organize transport The supplier is to organize transport for the items being returned. GS1 Note: Replaces GS1 Temporary Code 4E.
CV	Buyer to organize transport The buyer is to organize transport for the items being returned. GS1 Note: Replaces GS1 Temporary Code 5E.
CW	Prepare for collection The items are to be prepared for collection. GS1 Note: Replaces GS1 Temporary Code 8E.
CX	Prepare for collection on specified date The items are to be prepared for collection on the specified date. GS1 Note: Replaces GS1 Temporary Code 9E.
EM	Electronic mail Instructions to advise beneficiary by electronic mail.
EX	Expedite Forward the information to requested party immediately.

---

### 4403

Instruction type code qualifier  
Code qualifying the type of instruction.

1	Action required Instruction requires action.
2	Party instructions The instructions are to be executed by means of a party.
34	Return instruction An instruction concerning the return of items. GS1 Note: Replaces GS1 Temporary Code 10E.
10E	Return instruction (GS1 Temporary Code) An instruction concerning the return of identified goods. GS1 Note: Code marked for deletion. Use value 34 instead.
11E	Action completed (GS1 Temporary Code) Instruction informs action completed.

---

### 4405

Status description code  
Code specifying a status.  
EAN Description:  
The UN/EDIFACT code values are not unique. To prevent collision, some codes have been defined as EAN Codes.

**Used Codes**

1	To be done Remark that the requested service in the order remains outstanding.
3	Arrival, in defective condition [UN/Rec24 transport status] GS1 Description: Goods/consignments/equipment has been received or a means of transport has arrived in a defective condition.
4	Final The amount has the status of finality.
5	Subject to final payment The amount is subject to finality.
6	Minimum The amount quoted is a minimum tariff.
7	Fixed The amount quoted is a fixed tariff.
8	Maximum The amount quoted is a maximum tariff.
9	Information The amount is quoted for information only, it is not part of the charges to be deducted or added.
10	Cleared by agriculture, food or fisheries authorities [UN/Rec24 transport status] The goods/consignment/equipment/means of transport has been cleared by agriculture, food or fisheries authorities. GS1 Description: Goods/consignments/equipment have been held prior to shipment and are now cleared for shipment following examination by relevant authority.
11	Cleared by port authority [UN/Rec24 transport status] The goods/consignment/equipment/means of transport has been cleared by port authority. GS1 Description: The port authority has given permission for the goods/consignments/equipment/means of transport to leave the port.
12	Cleared by customs [UN/Rec24 transport status] The goods/consignment/equipment/means of transport has been cleared by customs. GS1 Description: Customs have cleared goods/consignments for import/export.

## Used Codes

---

13	<p>Collection/pick-up, completed  [UN/Rec24 transport status]  The goods/consignment/equipment has been collected/picked-up.  GS1 Description:  Goods/consignments/equipment have been collected from a predetermined location.</p>
14	<p>Process, completed  [UN/Rec24 transport status]  The process has been completed.</p>
15	<p>Consolidated  [UN/Rec24 transport status]  The goods/consignments have been consolidated.  GS1 Description:  Goods/consignments have been added to other goods/consignments to form a larger consignment and/or have been incorporated into one or more containers/units.</p>
16	<p>Crossed border  [UN/Rec24 transport status]  The goods/consignments/equipment/means of transport has crossed a border.  GS1 Description:  Goods/consignments/equipment have crossed a border from one country to another.</p>
17	<p>Customs clearance, refused  [UN/Rec24 transport status]  The goods/consignment/equipment/means of transport has been refused to be cleared by the customs authorities.  GS1 Description:  The Customs authorities have refused to clear the goods/consignments/equipment.</p>
18	<p>Damaged in the course of transportation  [UN/Rec24 transport status]  The goods/consignment/equipment has been damaged in the course of transportation.  GS1 Description:  Goods/consignments/equipment have been damaged in the course of transportation.</p>
19	<p>Equipment, damage quoted for  [UN/Rec24 transport status]  Damaged equipment has been assessed and a repair quotation has been sent.  GS1 Description:  Damaged equipment has been assessed and the quotation sent to lessor.</p>

## Used Codes

---

20	<p>Delayed, in the course of transportation [UN/Rec24 transport status] The goods/consignment/equipment/means of transport has been delayed in the course of transportation. GS1 Description: Goods/consignments/equipment have been delayed in the course of transportation.</p>
21	<p>Delivery, completed [UN/Rec24 transport status] The goods/consignment/equipment has been delivered. GS1 Description: The goods/consignments/equipment have been delivered to a location/party in the transport chain.</p>
22	<p>Subject to agreed condition Subject to agreed condition.</p>
23	<p>Delivery, not completed [UN/Rec24 transport status] Delivery of the goods/consignment/equipment has not been completed. GS1 Description: Delivery of the goods/consignments/equipment has not been completed as per definition.</p>
24	<p>Departure, completed [UN/Rec24 transport status] The means of transport has departed. GS1 Description: The means of transport has departed from a location in the transport chain.</p>
25	<p>Departure, delayed [UN/Rec24 transport status] The means of transport has been delayed in departure. GS1 Description: The transport has been delayed in departing on the arranged transport action.</p>
26	<p>Deramped [UN/Rec24 transport status] The equipment has been removed from a position above another type of equipment and/or on a means of transport. GS1 Description: Equipment has been removed from a position above other equipment on a means of transport.</p>
27	<p>Despatch, completed [UN/Rec24 transport status] The goods/consignment/equipment has been despatched. GS1 Description: The goods/consignments/equipment have departed from a location in the transport chain.</p>

## Used Codes

---

28	<p>Stripped  [UN/Rec24 transport status]  The goods/consignment/equipment has been unloaded from a piece of equipment in which they were transported.  GS1 Description:  The goods/consignments/equipment have been unloaded from equipment in which they were transported.</p>
29	<p>Unloaded  [UN/Rec24 transport status]  The goods/consignment/equipment has been unloaded from a means of transport.  GS1 Description:  The goods/consignments/equipment have been unloaded from a means of transport.</p>
30	<p>Empty on inspection  [UN/Rec24 transport status]  The package/equipment has been found to be empty on inspection.  GS1 Description:  The package/equipment has been found to be empty.</p>
31	<p>En route  [UN/Rec24 transport status]  The goods/consignment/equipment/means of transport is moving to destination.  GS1 Description:  The goods/consignments/equipment are in the normal course of transportation to the next destination.</p>
32	<p>Equipment, returned from repair  [UN/Rec24 transport status]  The equipment has been returned from repair.  GS1 Description:  A piece of equipment has been received in after having been sent out for repair.</p>
33	<p>Equipment, sent for repair  [UN/Rec24 transport status]  The equipment has been sent for repair.  GS1 Description:  A piece of equipment has been sent out for repair.</p>
34	<p>Equipment, repaired  [UN/Rec24 transport status]  The equipment has been repaired.  GS1 Description:  A damaged piece of equipment has been repaired.</p>

## Used Codes

---

35	<p>Forwarded to destination  [UN/Rec24 transport status]  The goods/consignment/equipment has been forwarded to a destination.  GS1 Description:  The goods/consignments/equipment have been expedited to the next/final destination in the transport chain.</p>
36	<p>Not found  [UN/Rec24 transport status]  The goods/consignment/equipment/means of transport has not been found.  GS1 Description:  The goods/consignments/equipment notified to be missing has not been located.</p>
37	<p>Stolen  A consignment or goods have been stolen.</p>
38	<p>Freight paid  [UN/Rec24 transport status]  The freight charges have been paid.  GS1 Description:  The freight charges on goods/consignments/equipment have been paid.</p>
39	<p>Released from bond  [UN/Rec24 transport status]  The goods/consignment/equipment has been released from bond.  GS1 Description:  The goods/consignments/equipment has been moved/is available to be moved from bond.</p>
40	<p>Arrival, at port  [UN/Rec24 transport status]  The goods/consignment/equipment has arrived at the port.  GS1 Description:  The goods/consignments/equipment has arrived/is available at port.</p>
45	<p>Arrival, consignee informed  [UN/Rec24 transport status]  The consignee has been informed of the arrival of the goods/consignments/equipment/means of transport.  GS1 Description:  The consignee has been informed formally of the arrival at a transit or final destination of goods/consignments/equipment.</p>
46	<p>Moved, into bond  [UN/Rec24 transport status]  The goods/consignment/equipment has been moved into bond.  GS1 Description:  The goods/consignments/equipment has been moved/is available to be moved into bond.</p>

## Used Codes

---

47	<p>Moved, into packing depot  [UN/Rec24 transport status]  The goods/consignment/equipment has been moved into a packing depot.  GS1 Description:  The goods/consignments/equipment has been moved into a LCL (less than container load)/packing depot.</p>
48	<p>Loading, completed onto a means of transport  [UN/Rec24 transport status]  The goods/consignment/equipment has been loaded onto a means of transport.  GS1 Description:  The goods/consignments/equipment have been loaded onto a means of transport.</p>
49	<p>Lost  [UN/Rec24 transport status]  The goods/consignment/equipment/means of transport has been lost.  GS1 Description:  The goods/consignments/equipment have been lost in the course of a movement along the transport chain.</p>
50	<p>Manifested  [UN/Rec24 transport status]  The goods/consignment/equipment has been included on a manifest .  GS1 Description:  The goods/consignments/equipment have been included on the list of items moving from one location to another in the transport chain.</p>
58	<p>Quantity error  The quantity is an error.</p>
59	<p>Monetary amount error  The monetary amount is an error.</p>
60	<p>Product not ordered  The product was not ordered.</p>
63	<p>Not accepted  The item has not been accepted.</p>
64	<p>Order or request cancelled  The referenced order or request has been cancelled.</p>
65	<p>Equipment, plugged-in  [UN/Rec24 transport status]  The equipment has been plugged into a power source.  GS1 Description:  Equipment, e.g. a refrigerated container, has been plugged into the power source.</p>



**Used Codes**

66	Plundered [UN/Rec24 transport status] The goods/consignment/equipment/means of transport has been plundered. GS1 Description: The goods/consignments/equipment has been plundered.
67	Positioned [UN/Rec24 transport status] The goods/consignment/equipment has been positioned. GS1 Description: Goods/consignments/equipment have been positioned on a means of transport.
68	Pre-informed [UN/Rec24 transport status] The party has been informed in advance. GS1 Description: The consignor/consignee has been advised in advance of a transport action.
70	Ramped equipment [UN/Rec24 transport status] The equipment has been placed above another type of equipment and/or placed on a means of transport. GS1 Description: Equipment has been placed above other equipment and placed on a means of transport.
71	Available for ordering Goods are available for ordering.
72	Not available for ordering Goods are not available for ordering.
73	Receipt of goods partially acknowledged [UN/Rec24 transport status] The receipt of goods has been partially acknowledged. GS1 Description: The consignee has not given full acknowledgement for the receipt of goods.
74	Expiry date exceeded The expiry date has been exceeded. GS1 Description: The expiry date for goods has been surpassed.
77	All published issues since issue specified in claim Applies to all published issues since issue specified in claim.
78	Released [UN/Rec24 transport status] The goods/consignment/equipment has been released. GS1 Description: Goods/consignments/equipment have been released to an authorized party.

## Used Codes

---

79	<p>Reloaded onto a means of transport [UN/Rec24 transport status] The goods/consignment/equipment has been reloaded onto a means of transport.</p>
80	<p>Returned as instructed [UN/Rec24 transport status] The goods/consignment/equipment has been returned as instructed. GS1 Description: The goods/consignments/equipment has been returned to a location as per instructions.</p>
81	<p>Returned as wreck [UN/Rec24 transport status] The goods/consignment/equipment/means of transport has been returned in a wrecked condition . GS1 Description: The goods/consignments/equipment has been returned in a wrecked condition to a location as per instructions.</p>
82	<p>Returned [UN/Rec24 transport status] The goods/consignment/equipment has been returned. GS1 Description: Goods/consignments/equipment have been returned to a previous location.</p>
83	<p>Sealed equipment [UN/Rec24 transport status] The equipment has been sealed. GS1 Description: The equipment has been sealed according to operational and governmental requirements.</p>
84	<p>Service ordered [UN/Rec24 transport status] A service has been ordered. GS1 Description: A service has been ordered in relation to the transportation of goods/consignments/equipment.</p>
85	<p>Short landed [UN/Rec24 transport status] Goods/consignments/equipment manifested for unloading have not been unloaded. GS1 Description: Goods/consignments/equipment expected to be discharged from a means of transport at a specific location have not been discharged.</p>

## Used Codes

---

86	<p>Short shipped  [UN/Rec24 transport status]  The goods/consignment/equipment expected to be sent has not been fully loaded onto a means of transport.  The goods/consignments/equipment expected to be sent to a specific destination on a selected means of transport from a specific location have not been loaded for onward delivery.</p>
88	<p>Split consignment  [UN/Rec24 transport status]  The consignment of goods has been split.  GS1 Description:  The consignment of goods has been split into two or more consignments.</p>
89	<p>Steam cleaned  [UN/Rec24 transport status]  The goods/equipment has been steam cleaned.  GS1 Description:  The equipment, e.g. a container, has been steam cleaned.</p>
90	<p>Movement stopped  [UN/Rec24 transport status]  The movement of the goods/consignment/equipment has been stopped .  GS1 Description:  The goods/consignments/equipment have been stopped from further movement in the transport chain.</p>
91	<p>Stored  [UN/Rec24 transport status]  The goods/consignment/equipment has been placed into storage.  GS1 Description:  The goods/consignments/equipment have been stored at a location.</p>
92	<p>Stowed  [UN/Rec24 transport status]  The goods/consignment/equipment has been placed on a means of transport.  GS1 Description:  The goods/consignments/equipment have been stowed for transportation in the selected equipment/means of transport.</p>
93	<p>Stuffed  [UN/Rec24 transport status]  The goods/consignments have been loaded into a piece of equipment.  GS1 Description:  The goods/consignments/equipment have been loaded into a piece of equipment, e.g. a container.</p>
94	<p>Stuffed and sealed  [UN/Rec24 transport status]  The goods/consignments have been loaded into a piece of equipment and the equipment has been sealed.  GS1 Description:  The goods/consignments/equipment have been loaded into a piece of equipment and the equipment has been sealed.</p>

## Used Codes

---

95	<p>Sub-lease notice in [UN/Rec24 transport status] A sub-lease notice has been sent to the lessor. GS1 Description: In the leasing of equipment a sub-lease has been notified to the lessor.</p>
96	<p>Sub-lease notice out [UN/Rec24 transport status] A sub-lease notice has been sent by the lessee. GS1 Description: In the leasing of equipment a sub-lease has been notified by a lessee.</p>
97	<p>Damage surveyed [UN/Rec24 transport status] The goods/consignment/equipment has been surveyed to assess the damage. GS1 Description: Damaged goods/consignments/equipment have been officially surveyed by a third party to assess the extent of damage.</p>
98	<p>Transferred in [UN/Rec24 transport status] The goods/consignment/equipment has been transferred in. GS1 Description: The goods/consignments/equipment have been transferred in from another location.</p>
99	<p>Transferred out [UN/Rec24 transport status] The goods/consignment/equipment has been transferred out. GS1 Description: The goods/consignments/equipment have been transferred out to another location.</p>
100	<p>Transshipment [UN/Rec24 transport status] The goods/consignment/equipment has been transferred to another means of transport. GS1 Description: The goods/consignments/equipment have been transhipped to another means of transport.</p>
101	<p>Delayed in transit [UN/Rec24 transport status] The goods/consignment/equipment/means of transport has been delayed in transit. GS1 Description: The goods/consignments/equipment has been delayed in transit.</p>
102	<p>Unknown [UN/Rec24 transport status] The goods/consignment/equipment/means of transport is not known. GS1 Description: The goods/consignments/equipment are not known to the source being enquired upon.</p>

## Used Codes

---

103	Equipment, unplugged [UN/Rec24 transport status] The equipment has been removed from the power source. GS1 Description: Equipment, e.g. a refrigerated container, has been unplugged from the power source at a given location.
110	Stock quantity corrected A difference in quantity between stocks has been corrected.
117	Washed The object is washed. EDIFACT
118	Unwashed The object is wnot ashed. EDIFACT
314	Delayed, at origin [UN/Rec24 transport status] The goods/consignment/equipment/means of transport has been delayed at the origin.
315	Held, by logistic service provider [UN/Rec24 transport status] The goods/consignment/equipment has been held by the logistic service provider.
316	Incident occurred but accepted by ordering party [UN/Rec24 transport status] An incident has occurred but has been accepted by the ordering party.
317	Delivery party' premises closed during normal hours [UN/Rec24 transport status] The premises of the delivery party were closed during normal hours.
319	Despatch, preparation error [UN/Rec24 transport status] An error occurred during the preparation of the despatch.
324	Instruction to despatch, cancelled [UN/Rec24 transport status] The instruction to despatch has been cancelled.
326	Goods, held by third party on instruction from owner [UN/Rec24 transport status] Goods are held under control of a third party following an instruction from the owner of the goods.
327	Weight or volume loss [UN/Rec24 transport status] The goods have suffered a weight or volume loss.

## Used Codes

---

328	Moved, internally [UN/Rec24 transport status] The goods/consignment/equipment has been moved internally.
329	Consignment partially stolen [UN/Rec24 transport status] The consignment has been partially stolen.
330	Consignment partially lost or missing [UN/Rec24 transport status] The consignment is partially lost or missing.
355	En route, via local route [UN/Rec24 transport status] The goods/consignment/equipment/means of transport is moving to destination via a local route.
356	En route, via national route [UN/Rec24 transport status] The goods/consignment/equipment/means of transport is moving to destination via a national route.
357	En route, via international route [UN/Rec24 transport status] The goods/consignment/equipment/means of transport is moving to destination via an international route.
1E	Arrived (GS1 Temporary Code) The goods/consignments/equipment/means of transport has arrived at a location.
20E	Direct deliver (GS1 Temporary Code) The order or goods are to be delivered direct to the consignee. GS1 Note: Code marked for deletion.
21E	Delivery through warehouse (GS1 Temporary Code) The order or goods are to be delivered to the consignee via a warehouse or distribution center. GS1 Note: Code marked for deletion.
22B	Delivery, completed as per instruction [UN/Rec24 transport status] Delivery of the goods/consignment/equipment has been completed as per instruction. GS1 Description: Delivery of the goods/consignments/equipment has been completed as per instruction.
22E	Despatched urgent (GS1 Temporary Code) The order or goods have been urgently despatched to the consignee.
23E	Delivered cash on delivery (GS1 Temporary Code) The order or goods have been delivered to the consignee cash on delivery.

## Used Codes

---

24E	Delivered previous call (GS1 Temporary Code) The order or goods have been delivered to the consignee following calls to previous locations.
26E	Not enough information for despatch (GS1 Temporary Code) Not enough information was provided to enable the despatch of the order or goods.
27E	Local delivery ready for despatch (GS1 Temporary Code) A local delivery of an order or goods is ready for despatch.
28E	Long distance delivery ready for despatch (GS1 Temporary Code) A long distance delivery of an order or goods is ready for despatch.
29E	Local delivery expedited (GS1 Temporary Code) A local delivery of an order or goods has been expedited to its destination.
2E	Authorized to load (GS1 Temporary Code) Permission to load has been given by the responsible party.
30E	Long distance delivery expedited (GS1 Temporary Code) A long distance delivery of an order or goods has been expedited to its destination.
31E	Despatch being prepared (GS1 Temporary Code) An order or goods are currently being prepared for despatch.
32E	Modified order (GS1 Temporary Code) The referenced order has been modified according to an agreement between the trading parties. GS1 Note: Code marked for deletion.
34E	Collected by the consignee (GS1 Temporary Code) An order or goods has been collected by the consignee.
37B	Found [UN/Rec24 transport status] The goods/consignment/equipment/means of transport has been found. GS1 Description: The goods/consignments/equipment previously notified missing have now been located.
39E	Goods returned by recipient (GS1 Temporary Code) A code indicating the fact that goods delivered were returned by the recipient.
49E	Delivery in-complete - time shortage at delivery location (GS1 Temporary Code) The carrier was unable to complete the delivery of goods due to a shortage of time at the delivery location to handle the delivery.
4E	Defective equipment release (GS1 Temporary Code) Equipment previously the subject of a 'defective condition' status has been returned to service.

## Used Codes

---

50E	Other (GS1 Temporary Code) An other incident (undefined) has occurred.
57E	Goods moved to replenish stock (GS1 Temporary Code) An indication that goods have been moved to replenish stock.
58E	Instruction to despatch arrived (GS1 Temporary Code) An indication from the logistic service provider that the Instruction To Despatch message has arrived.
59E	Despatch preparation (GS1 Temporary Code) An indication that goods have been being prepared for despatch.
5E	Begun (GS1 Temporary Code) The process has begun.
60E	Being returned (GS1 Temporary Code) Goods originally despatched are in the process of being returned from the delivery party.
62E	Refused by recipient (GS1 Temporary Code) Indication that the delivery of goods has been refused by the recipient.
64B	Collection/pick-up, awaited [UN/Rec24 transport status] The goods/consignment/equipment is awaiting collection/pick-up. GS1 Description: Goods/consignments/equipment are awaiting pick-up.
64E	Load planning safety margin (GS1 Temporary Code) Identifies the consignment(s) which can be used to compensate for load planning mistakes. GS1 Note: Code marked for deletion.
65E	To be loaded according to load planning (GS1 Temporary Code) Consignment is to be loaded according to load planning GS1 Note: Code marked for deletion.
69E	Damaged (GS1 Temporary Code) The goods/consignments/equipment have been damaged.
6E	Booked (GS1 Temporary Code) Goods/consignments/equipment or means of transport has been booked for subsequent movements.
70E	Handover (GS1 Temporary Code) The goods/consignments/equipment have been formally passed from one point in the transport chain to another under responsibility of the same transporter. (See also 'handover delivered'.)



## Used Codes

---

71B	<p>Ready for transportation [UN/Rec24 transport status] The goods/consignment/equipment is ready for transportation. GS1 Description: Goods/consignments/equipment have been made ready for transportation.</p>
71E	<p>Handover delivered (GS1 Temporary Code) The goods/consignments/equipment from one transport operator have been passed to another transport operator. (See also 'handover'.)</p>
72B	<p>Receipt of goods fully acknowledged (GS1 Temporary Code) [UN/Rec24 transport status] The receipt of goods has been fully acknowledged. GS1 Description: The consignee has given full acknowledgement for the receipt of goods.</p>
72E	<p>Handover received (GS1 Temporary Code) The goods/consignments/equipment have been received by one transport operator from another transport operator.</p>
73E	<p>Ill-routed consignment reforwarded (GS1 Temporary Code) The goods/consignments/equipment which was previously sent to a wrong destination is on the way to correct destination.</p>
74B	<p>Received [UN/Rec24 transport status] The goods/consignment/equipment have been received. GS1 Description: Goods/consignments/equipment have been received at a location/party in the transport chain.</p>
74E	<p>Offloaded (GS1 Temporary Code) The consignment has been offloaded.</p>
75E	<p>Not identified (GS1 Temporary Code) The goods/consignments/equipment expected to be located and identified in the transport chain cannot be identified.</p>
76E	<p>Not collected (GS1 Temporary Code) The goods/consignments/equipment expected to be collected after transportation have not been collected.</p>
77B	<p>Refused, action [UN/Rec24 transport status] The transport action has been refused. GS1 Description: The transport action/documentation has been refused.</p>
77E	<p>Not delivered (GS1 Temporary Code) The goods/consignments/equipment have not been delivered.</p>
78E	<p>Not loaded (GS1 Temporary Code) The goods/consignments/equipment to be loaded onto a means of transport have not been loaded on the expected transport.</p>

**Used Codes**

79E	Off hire (GS1 Temporary Code) Equipment previously under hire to a customer has been returned to the lessor and the contract has been terminated.
7E	Booking cancelled (GS1 Temporary Code) The booking of goods/consignments/equipment or means of transport previously booked has been cancelled.
80E	On hire (GS1 Temporary Code) Equipment has been hired out to a hirer/customer.
81E	Outstanding claims settled (GS1 Temporary Code) Outstanding claims in respect of goods/consignments/equipment have been settled.
82E	Over landed (GS1 Temporary Code) Goods/consignments/equipment have been discharged from a means of transport at a specific location when they were not expected to be discharged.
83E	Package not ready (GS1 Temporary Code) The package was not available for collection.
84E	Put to refuse (GS1 Temporary Code) The goods/consignments/equipment has been written off and disposed of.
85E	Reconsigned (GS1 Temporary Code) Goods/consignments/equipment have been consigned to a party other than the original or subsequent consignees.
86E	Reforwarding on request (GS1 Temporary Code) The goods/consignments/equipment which has been delayed will be/has been reforwarded on request by appropriate authority.
87E	Sorted wrong route (GS1 Temporary Code) The goods/consignments/equipment has been sorted erroneously to an incorrect route.
8E	Cleared import restrictions (GS1 Temporary Code) Goods/consignments/equipment held for import restriction purposes have been released for import.
9E	Cleared export restrictions (GS1 Temporary Code) Goods/consignments/equipment held prior to loading have now been cleared for export.
CSA	Claim all issues since subscription start (GS1 Temporary Code) Claim refers to all issues since subscription start. GS1 Note: Code marked for deletion.
CSC	Claim all issues from and including issue specified in claim (GS1 Temporary Code) Claim refers to all issues from and including issue specified in claim. GS1 Note: Code marked for deletion.

## Used Codes

---

CSD	Claim specified issue only (GS1 Temporary Code) Claim refers to specified issue only. GS1 Note: Code marked for deletion.
CSE	Claim cancelled (GS1 Temporary Code) Claim is cancelled. GS1 Note: Code marked for deletion.
X33	Damaged in the logistics service provider premises (GS1 Temporary Code) Goods/consignments/equipment have been damaged in the logistics service provider's premises while under the LSP responsibility.
X34	Goods destroyed by the logistics service provider (GS1 Temporary Code) The goods have been destroyed by the logistics service provider, by order of the owner of the goods after an event had occurred (the goods had been damaged, the best before date was exceeded, frozen goods had melted, etc).
X35	Released by the logistics service provider (GS1 Temporary Code) Goods/consignments/equipment have been released by the logistics service provider. They had been earlier blocked by the logistics service provider, e.g. to allow broken pallets to be sorted.
X38	In use (GS1 Temporary Code) The object is in use. GS1 Note: Code marked for deletion.
X40	Available (GS1 Temporary Code) Goods are available.
X41	Not available (GS1 Temporary Code) Goods are not available.
<b>4441</b>	Free text value code Code specifying free form text.
78E	Proof Of Delivery (GS1 Permanent Code) The mentioned URL refers to a Proof of Delivery document. This Code value can be used if DE 4451 of the FTX segment is ZXL.
<b>4451</b>	Text subject code qualifier Code qualifying the subject of the text.
1E	Additional product information address (GS1 Temporary Code) Address at which additional information on the product can be found. GS1 Note: Code marked for deletion. Use value BAI instead.
2E	VAT exemption (GS1 Temporary Code) VAT exemption reason in clear text. GS1 Note: Code marked for deletion. Use value BAQ instead.

## Used Codes

---

3E	Tracking URL (GS1 Temporary Code) The internet link (URL) to track the delivery of a specific package or consignment.
AAA	Goods description [7002] Plain language description of the nature of the goods sufficient to identify them at the level required for banking, Customs, statistical or transport purposes, avoiding unnecessary detail (Generic term).
AAB	Terms of payments [4276] Conditions of payment between the parties to a transaction (generic term).
AAC	Dangerous goods additional information Additional information concerning dangerous goods.
AAD	Dangerous goods, technical name Proper shipping name, supplemented as necessary with the correct technical name, by which a dangerous substance or article may be correctly identified or which is sufficiently informative to permit identification by reference to generally available literature.
AAG	Party instructions Indicates that the segment contains instructions to be passed on to the identified party.
AAI	General information The text contains general information.
AAK	Price conditions Information on the price conditions that are expected or given.
AAM	Equipment re-usage restrictions Technical or commercial reasons why a piece of equipment may not be re-used after the current transport terminates.
AAN	Handling restriction Restrictions in handling depending on the technical characteristics of the piece of equipment or on the nature of the goods.
AAO	Error description (free text) Error described by a free text.
AAR	Terms of delivery (4053) Free text of the non Incoterms terms of delivery. For Incoterms, use: 4053.
AAW	Letter of credit information Information pertaining to the letter of credit.
AAZ	Additional export information The text contains additional export information.

## Used Codes

---

ABN	Accounting information Self explanatory. GS1 Description: Free text information regarding account.
ABO	Discrepancy information Free text or coded information to indicate a specific discrepancy.
ABU	Deferred payment termed additional Additional terms concerning deferred payment.
ACB	Additional information The text contains additional information.
ACD	Reason Reason for a request or response.
ACE	Dispute A notice, usually from buyer to seller, that something was found wrong with goods delivered or the services rendered, or with the related invoice.
ACF	Additional attribute information The text refers to information about an additional attribute not otherwise specified.
ACL	Quality Statement Code A statement on the quality of an object.
ADK	Promotion information The text contains information about a promotion.
ADL	Meter condition Description of the condition of a meter.
ADM	Meter reading information Information related to a particular reading of a meter.
ADS	Booked item information (SWIFT Code) Information pertaining to a booked item. GS1 Description: Information related to an item booked onto a financial account.
AEI	Instructions to the applicant Instructions given to the applicant.
AFF	Batch code structure A description of the structure of a batch code.
AFG	Product application A general description of the application of a product.
AGW	Location Description of a location.

## Used Codes

---

AGZ	Marketing activities Information concerning marketing activities.
AIP	Question A free text question.
AIQ	Party information Free text information related to a party.
AIX	Warranty terms Text describing the terms of warranty which apply to a product or service.
ALL	All documents The note implies to all documents.
BAI	Additional product information address Address at which additional information on the product can be found. GS1 Note: Replaces GS1 Temporary Code 1E.
BAJ	Information to be printed on despatch advice Specification of free text information which is to be printed on a despatch advice. GS1 Note: Replaces GS1 Temporary Code DSI.
BAK	Missing goods remarks Remarks concerning missing goods. GS1 Note: Replaces GS1 Temporary Code MIS.
BAL	Non-acceptance information Information related to the non-acceptance of an order, goods or a consignment. GS1 Note: Replaces GS1 Temporary Code NAI.
BAM	Returns information Information related to the return of items. GS1 Note: Replaces GS1 Temporary Code RTI.
BAN	Sub-line item Note contains information related to sub-line item data. GS1 Note: Replaces GS1 Temporary Code SID.
BAO	Test information Information of a test. GS1 Note: Replaces GS1 Temporary Code TIN.
BAP	External link The external link to a digital document (e.g.: URL) GS1 Note: Replaces GS1 Temporary Code ZXL.
BAQ	VAT exemption reason The reason for Value Added Tax exemption. GS1 Note: Replaces GS1 Temporary Code 2E.

**Used Codes**

BLR	Transport document remarks Remarks concerning the complete consignment to be printed on the bill of lading.
BLV	B2C marketing information, short description Consumer marketing information, short description.
BLW	B2B marketing information, long description Trading partner marketing information, long description.
BLX	B2C marketing information, long description Consumer marketing information, long description.
BLY	Product ingredients Information on the ingredient make up of the product. Information on the constituent ingredient make up of the product specified as one string. Example: FTX+ING+1+ +Tomato puree (54%), water, onions (9%), sunflower seed oil' FTX+ING+1+ +(cold pressed, untempered, unrefined) (10%), corn syrup (2%), soy protein (12%) .....::+EN'
CHG	Change information Note contains change information.
CIP	Customs clearance instruction import Any coded or clear instruction agreed by customer and carrier regarding the import declaration of the goods.
CLR	Loading remarks Instructions concerning the loading of the container.
CUS	Customs declaration information Note contains customs declaration information.
DAR	Damage remarks Remarks concerning damage on the cargo.
DEL	Delivery information Information about delivery.
DIN	Delivery instructions Instructions regarding the delivery of the cargo.
DSI	Information to be printed on despatch advice (GS1 Temporary Code) Specification of free text information which is to be printed on a despatch advice. GS1 Note: Code marked for deletion. Use value BAJ instead.
DUT	Duty declaration The text contains a statement constituting a duty declaration.

## Used Codes

GEN	Entire transaction set Note is general in nature, applies to entire transaction segment.
HAN	Handling instructions [4078] Instructions on how specified goods, packages or containers should be handled.
HAZ	Hazard information Information pertaining to a hazard.
IIN	Insurance instructions Instructions regarding the cargo insurance.
INS	Insurance information Specific note contains insurance information.
INV	Invoice instruction Note contains invoice instructions.
ITS	Testing instructions Instructions regarding the testing that is required to be carried out on the items in the transaction.
LIN	Line item Note contains line item information.
LOI	Loading instruction Instructions where specified packages or containers are to be loaded on a means of transport.
MIS	Missing goods remarks (GS1 Temporary Code) Remarks concerning missing goods. GS1 Note: Code marked for deletion. Use value BAK instead.
MKS	Additional marks/numbers information Additional information regarding the marks and numbers.
NAI	Non-acceptance information (GS1 Temporary Code) Information related to the non-acceptance of an order, goods or a consignment. GS1 Note: Code marked for deletion. Use value BAL instead.
ORI	Order instruction Free text contains order instructions.
OSI	Other service information General information created by the sender of general or specific value.
PAC	Packing/marking information Information regarding the packaging and/or marking of goods.
PAY	Payables information Note contains payables information.



## Used Codes

---

PKG	Packaging information Note contains packaging information. GS1 Description: Note contains packaging instructions.
PMD	Payment detail/remittance information The free text contains payment details.
PMT	Payment information Note contains payments information.
PRD	Product information The text contains product information.
PRF	Price calculation formula Additional information regarding the price formula used for calculating the item price.
PRI	Priority information Note contains priority information.
PUR	Purchasing information Note contains purchasing information.
QQD	Quality demands/requirements Specification of the quality/performance expectations or standards to which the items must conform.
QUT	Quotation instruction/information Note contains quotation information.
REG	Regulatory information The free text contains information for regulatory authority.
RET	Return to origin information Free text information on an IATA Air Waybill to indicate consignment returned because of non delivery.
REV	Receivables The text contains receivables information.
RQR	Requested routes/routing instructions [3074] Names of places via which the consignor requests a consignment to be routed.
RQT	Tariffs and route requested [4120] Stipulation of the tariffs to be applied showing, where applicable, special-agreement numbers or references; indication of routes by frontier points or by frontier stations and, when necessary, by transit stations between.
RTI	Returns information (GS1 Temporary Code) Information related to the return of goods. GS1 Note: Code marked for deletion. Use value BAM instead.

## Used Codes

SAF	Safety information The text contains safety information.
SIC	Sender's instruction to carrier [4284] Instructions given and declarations made by the sender to the carrier concerning Customs, insurance, and other formalities.
SID	Sub line item (GS1 Temporary Code) Note contains information related to sub line item data. GS1 Note: Code marked for deletion. Use value BAN instead.
SIN	Special instructions Special instructions like licence no, high value, handle with care, glass.
SPH	Special handling Note contains special handling information.
SSR	Special service request Request for a special service concerning the transport of the goods.
SUR	Supplier remarks Remarks from or for a supplier of goods or services.
TIN	Test information (GS1 Temporary Code) Information related to a test which will be, or has been, carried out. GS1 Note: Code marked for deletion. Use value BAO instead.
TRA	Transportation information General information regarding the transport of the cargo.
TXD	Tax declaration The text contains a statement constituting a tax declaration.
WHI	Warehouse instruction/information Note contains warehouse information.
XYZ	No partial delivery (GS1 Temporary Code) The goods that are not delivered have to be re-ordered by the buyer. Supplier only delivers the goods they have in stock at that moment. One order leads to one delivery.
ZXL	External link (GS1 Temporary code) The external link to a digital document (e.g.: URL) GS1 Note 1: This Code value can be used if no EFI segment is available. If the type of the referenced document (e.g. proof-of-delivery.pdf) can be identified by a code value of DE 1001, this code value should be used to fill DE 4441. (e.g. 78E), DE 3055 = 9. GS1 Note 2: Code marked for deletion. Use value BAP instead.
ZYZ	Partial delivery allowed (GS1 Temporary Code) The supplier keeps delivering until the entire order is fulfilled. One order can lead to many deliveries. The buyer doesn't need to place a new order; they just waits for the other goods to be delivered.

## Used Codes

---

ZZZ	Mutually defined Note contains information mutually defined by trading partners.
<b>4463</b>	Intra-company payment indicator code Code indicating an intra-company payment.
1	Intra-company payment Moving funds between accounts, where the account owner is one company or belonging to a group of companies.
<b>4465</b>	Adjustment reason description code Code specifying the adjustment reason.
1	Agreed settlement Self explanatory. GS1 Description: Adjustment has been made as part of an agreed settlement.
2	Below specification goods Goods of inferior quality.
3	Damaged goods Self explanatory. GS1 Description: Adjustment has been made because of damaged goods.
4	Short delivery Self explanatory. GS1 Description: Adjustment has been made to take into account short delivery.
5	Price query Self explanatory. GS1 Description: Adjustment has been made to take into account a price query.
6	Proof of delivery required The buyer requires that proof of delivery be made before payment. GS1 Description: Adjustment because no proof of delivery was available.
7	Payment on account Buyer is to make payment later. GS1 Description: Adjustment has been made because payment is on account.
8	Returnable container charge included Adjustment made to deduct the returnable container charge. GS1 Description: Adjustment has been made because of an included returnable container charge.

**Used Codes**

9	Invoice error Invoice not in accordance with the order. GS1 Description: Adjustment has been made to take into account invoice error.
14	Wrong delivery Delivery not according to specifications.
16	Goods partly returned Goods partly returned.
17	Transport damage Goods damaged in transit.
18	Goods on consignment Buyer does not accept invoice(s) charge as it relates to goods where the ownership remains with the seller until sold.
19	Trade discount Trade discount deducted from payment.
20	Discount for late delivery Penalty amount deducted for later delivery.
21	Advertising costs Advertising costs deducted from payment.
26	Taxes Taxes deducted from payment.
32	Goods not delivered Buyer has not received the goods.
35	Goods returned Buyer returned the goods to seller.
38	Deducted bonus Buyer has/will deduct a bonus he is entitled to from payment.
40	Deducted freight costs Buyer has/will deduct freight costs from the payment
52	Wrong invoice Invoice issued to wrong party.
56	Incorrect discount Buyer states that calculated discount on the invoice(s) is wrongly calculated.
57	Price change Price has been changed.
64	Expecting new terms Buyer expects that seller revises the terms of payment of an invoice.

**Used Codes**

66	Cash discount An adjustment has been made due to the application of a cash discount.
67	Delcredere costs Costs deducted from a total amount to pay for the services of central payment.
68	Early payment allowance adjustment Adjustment results from the application of an early payment allowance.
69	Incorrect due date for monetary amount Adjustment has been made because an incorrect due date was referred to with regard to the monetary amount.
70	Wrong monetary amount resulting from incorrect free goods quantity Adjustment has been made because of a wrong monetary amount resulting from an incorrect free goods quantity.
71	Rack or shelf replenishment service by a supplier Adjustment due to the replenishment of the racks or shelves by a supplier.
72	Temporary special promotion Adjustment due to a temporary special promotion. GS1 Note: Replaces GS1 Temporary Code 37E.
73	Difference in tax rate Adjustment due to a difference in tax rate.
74	Quantity discount Adjustment due to a quantity discount. GS1 Description: Quantity discount deducted from payment, when a purchase quantity threshold has been met or exceeded.
75	Promotion discount Adjustment due to a promotion discount.
77	Pricing discount An adjustment has been made due to the application of a pricing discount. EDIFACT
79	Sundry discount An adjustment has been made due to the application of a sundry discount. EDIFACT
90	Treasury management service charge Charge for the service of treasury management. This code is used if service provider responsible for treasury management is deducting the invoice by own service charge.
98	Incorrect references Adjustment has taken place because of incorrect references. GS1 Note: Replaces GS1 Temporary Code 10E.

**Used Codes**

99	<p>Incorrect identification of the buyer Adjustment has taken place because of incorrect identification of the buyer. GS1 Note: Replaces GS1 Temporary Code 12E.</p>
100	<p>Incorrect product identification Adjustment has taken place because of incorrect product identification. GS1 Note: Replaces GS1 Temporary Code 13E.</p>
101	<p>New employee The reason for the adjustment is a new employee. GS1 Note: Replaces GS1 Temporary Code 19E.</p>
102	<p>Employee retirement The reason for the adjustment is the retirement of an employee. GS1 Note: Replaces GS1 Temporary Code 20E.</p>
103	<p>Salary change The reason for the adjustment is a salary change. GS1 Note: Replaces GS1 Temporary Code 21E.</p>
104	<p>Parental leave The reason for the adjustment is a parental leave. GS1 Note: Replaces GS1 Temporary Code 22E.</p>
10E	<p>Incorrect references (GS1 Temporary Code) Adjustment has taken place because of incorrect references. GS1 Note: Code marked for deletion. Use value 98 instead.</p>
11E	<p>Incorrect charge (GS1 Temporary Code) Adjustment has taken place because of an incorrect charge.</p>
12E	<p>Incorrect identification of the buyer (GS1 Temporary Code) Adjustment has taken place because of incorrect identification of the buyer. GS1 Note: Code marked for deletion. Use value 99 instead.</p>
13E	<p>Incorrect product identification (GS1 Temporary Code) Adjustment has taken place because of incorrect product identification.</p>
19E	<p>New employee (GS1 Temporary Code) The reason of the adjustment is a new employee. GS1 Note: Code marked for deletion. Use value 101 instead.</p>
20E	<p>Employee retirement (GS1 Temporary Code) The reason of the adjustment is a retiring of the employee. GS1 Note: Code marked for deletion. Use value 102 instead.</p>
21E	<p>Salary change (GS1 Temporary Code) The reason of the adjustment is a salary change. GS1 Note: Code marked for deletion. Use value 103 instead.</p>
22E	<p>Maternity licence (GS1 Temporary Code) The reason for the adjustment is a maternity licence. GS1 Note: Code marked for deletion. Use value 104 instead.</p>

## Used Codes

---

23E	Job accident (GS1 Temporary Code) An adjustment is due to a job accident.
24E	No exceptional situation (GS1 Temporary Code) There are no exceptional situations.
25E	Temporary suspension of the contract (GS1 Temporary Code) When the contract is suspended, there are no contributions.
26E	Employee incapacity (GS1 Temporary Code) The employee's professional incapacity.
27E	Holiday (GS1 Temporary Code) An adjustment is due to holidays.
28E	Voluntary pension (GS1 Temporary Code) Voluntary pension amount.
29E	Change in salary (GS1 Temporary Code) A contribution change according to the salary.
30E	Special tariff (GS1 Temporary Code) Special tariff given.
31E	Various work places (GS1 Temporary Code) Person working in various places.
37E	Extraordinary promotion services (GS1 Temporary Code) Extraordinary, not permanent promotion services. GS1 Note: Code marked for deletion. Use value 72 instead.
ZZZ	Mutually defined A code assigned within a code list to be used on an interim basis and as defined among trading partners until a precise code can be assigned to the code list.
<b>4471</b>	Settlement means code Code specifying the means of settlement.
13	All charges borne by payee All charges are to be borne by the funds receiver. GS1 Description: All charges are to be borne by the beneficiary.
14	Each pay own cost Each party are to be responsible for its own charges.
15	All charges borne by payor All charges are to be borne by the funds sender. GS1 Description: All the charges are to be borne by the ordering customer.

## Used Codes

---

<b>4487</b>	Financial transaction type code Code specifying a type of financial transaction.
1	Clean payment Payment under open account terms.
4	Documentary payment Payment relating to a documentary settlement.
5	Irrevocable documentary credit The documentary credit is irrevocable.
6	Revocable documentary credit The documentary credit is revocable.
7	Irrevocable and transferable documentary credit The documentary credit is irrevocable and may be transferred to a second beneficiary.
8	Revocable and transferable documentary credit The documentary credit is revocable and may be transferred to a second beneficiary.
<b>5025</b>	Monetary amount type code qualifier Code qualifying the type of monetary amount.
1	VAT, 1st value First VAT value if, for the same rate of VAT, there are 1 to 3 different ways to set this value.
5	Adjusted amount The amount specified is the adjusted amount.
7	Agreed charge Charges which parties agreed upon.
8	Allowance or charge amount [5422] Total amount of allowance or charge.
9	Amount due/amount payable Amount to be paid.
11	Amount paid Amount that has been paid.
12	Amount remitted Amount which was remitted (see remittance advice).
13	Amount subject to total monetary discount The amount is subject to a total monetary discount.



## Used Codes

---

21	Cash discount Cash discount given by the seller to the buyer. GS1 Description: Cash discount given by the seller to the buyer where payment is made in advance of receipt of goods.
22	Cash on delivery amount Amount to be collected by carrier upon delivery of goods. This amount represents approximately the value of the goods.
23	Charge amount The amount of money charged for the provision of a service or product.
25	Charge/allowance basis The amount specified is the basis for calculation of charges/allowance.
36	Converted amount The amount is converted from another currency.
38	Invoice item amount (5068) Total sum charged in respect of a single Invoice item in accordance with the terms of delivery.
39	Invoice total amount [5444] Total sum charged in respect of one or more Invoices in accordance with the terms of delivery.
40	Customs value (5032) Value declared for Customs purposes on those goods in a consignment which are subject to the same Customs procedure, and have the same tariff/statistical heading, country information and duty regime.
43	Declared total Customs value [5070] Total value declared for Customs purposes of all goods in a consignment, whether or not they are subject to the same Customs procedure, or have the same tariff/statistical heading, country information, and duty regime.
44	Declared value for carriage (5036) Value, declared by the shipper or his agent solely for the purpose of varying the carrier's level of liability from that provided in the contract of carriage, in case of loss or damage to goods or delayed delivery.
48	Deposit total The whole amount of money that one entrusts for safekeeping.
50	Disbursements Amount of disbursements to be collected by the carrier according to the order given by the shipper.
51	Disbursements fee Fee charged for the collection of disbursements.

**Used Codes**

52	Discount amount The amount specified is the discount amount.
53	Discount amount due The amount of discount that is due. GS1 Description: The amount due for a discount.
55	Duty amount The amount of duty. GS1 Description: The amount due for a duty.
56	Duty/tax/fee basis amount The amount specified is the basis for duty/tax or fee.
57	Equivalent amount This amount is equivalent to the amount to be transferred, but in another currency.
60	Final (posted) amount The amount posted to an account, finally, after charges/allowances.
64	Freight charge Amount to be paid for moving goods, by whatever means, from one place to another, inclusive discounts, allowances, rebates, adjustment factors and additional cost relating to freight costs (UN/ECE Recommendation no 23).
74	Amount to be paid in advance Amount which is to be paid before goods are delivered or the service is rendered.
75	Registered capital Registered amount of equity of a company.
77	Invoice amount [5068] Total sum charged in respect of a single Invoice in accordance with the terms of delivery.
79	Total line items amount The sum of all the line item amounts.
81	Loading and handling cost Cost incurred by loading and handling.
83	Lumpsum An agreed sum of money, which is paid in full at one time. This term is often used in connection with charter parties.
86	Message total monetary amount The total of all monetary amounts contained within the message.
97	Offer amount [5210] Total amount of an offer.

**Used Codes**

98	Original amount Original amount, without charges, allowances or adjustment.
103	Other deductible charges Other charges deducted from the total invoice value.
106	Packing cost Cost for packing concerning labour and/or material.
109	Payment discount amount Amount subject to payment discount.
113	Prepaid amount (5302) Amount which has been prepaid in advance.
119	Received amount The amount is what the bank received, and the one before charges/allowances.
124	Tax amount Tax imposed by government or other official authority related to the weight/ volume charge or valuation charge.
125	Taxable amount Amount on which a tax has to be applied. GS1 Description: The monetary amount liable to tax.
126	To collect Amount that has to be collected.
128	Total amount The amount specified is the total amount.
129	Total amount subject to payment discount Part of the invoice amount which is subject to payment discount.
130	Total charge due Total amount of charges payable to the carrier.
131	Total charges/allowances The amount specified is the total of all charges/allowances.
134	Total declared The total value of declared amounts.
138	Total monetary discount amount Total of monetary discount amounts.
139	Total payment amount A complete charge for goods or services rendered.
140	Total service charge The complete payment owed to one who has performed work for another.

**Used Codes**

142	Trade discount Discount given to any purchaser at a particular commercial level e.g. at wholesale or retail level.
143	Transfer amount The amount which has been transferred from buyer to the sellers bank.
144	Transport charges (Customs) (5292) Cost incurred by shipper in moving goods, by whatever means, from one place to another under the terms of the contract of carriage, see UN/ECE Recommendation No 23. Synonym: freight charges (Customs).
146	Unit price (5110) Reporting monetary amount is a "per unit" amount.
150	Value added tax [5490] Amount in national currency resulting from the application, at the appropriate rate, of value added tax (or similar tax) to the invoice amount subject to such tax.
157	Insurance value (5010) Value for which the goods are insured.
159	Licence (value deducted) Amount in the currency of the licence to be written off from the total licence value.
161	Duty, tax or fee amount Amount of duty, tax or fee.
165	Adjustment amount Amount being the balance of the amount to be adjusted and the adjusted amount.
176	Message total duty/tax/fee amount Total of all duty/tax/fee amounts.
177	Message total amount prepaid Total of all prepaid amounts within the message.
178	Exact amount Specific amount. GS1 Description: A specific monetary amount.
200	Minimum amount due The minimum amount that must be paid on an amount now due for payment.
201	Penalty amount The penalty charge incurred if or because conditions are not met. GS1 Description: A value indicating a penalty amount.

**Used Codes**

202	Interest amount The amount of interest charged or paid on a debit or credit balance.
203	Line item amount Goods item total minus allowances plus charges for line item. See also Code 66.
204	Allowance amount The amount of an allowance.
209	Agent commission amount Amount which has to be paid to an agent.
210	Credit note amount Amount of a credit note.
211	Debit note amount Amount of a debit note.
212	Documentary credit amount Amount of the documentary credit.
227	Deposit Part of the amount of retention, not covered by guarantee of retention, and thus deducted from the amount paid to the contractor until release of retention. GS1 Description: The money paid as a guarantee in case one damages or loses something one is renting. This money is returned if no damage is caused.
236	Amount subject to price adjustment Amount which is used as the basis for price adjustment calculation.
257	Amount subject to dispute The amount that is being disputed.
259	Total charges Self-explanatory. GS1 Description: Total charges amount.
260	Total allowances Self-explanatory.
262	Instalment amount Amount paid or due for a single instalment of an instalment payment scheme.
263	Outstanding amount Amount still remaining outstanding for payment.
265	Commission amount Amount of any commission.

**Used Codes**

271	Nominal salary The salary amount without special allowances or other cash benefits.
272	Taxable salary The salary amount which is taxable.
276	Annual salary Self-explanatory.
277	Total contributions amount Sum of individual contributions.
278	Voluntary contribution amount The amount is for a non-compulsory contribution.
286	Administration charge Charge made for an administration activity.
289	Subtotal amount Total amount of money that is part of a complete amount.
296	Total authorised deduction Total amount of authorised deductions.
304	Other charges Miscellaneous charges.
315	Opening balance (SWIFT Code) The amount of the opening balance.
343	Closing balance (SWIFT Code) The closing balance is the last balance for a reporting period.
344	Value date balance (SWIFT Code) This is the balance on value date.
345	Cost amount for providing the balance (SWIFT Code) Cost information for providing the statement.
346	Total credits (SWIFT Code) The total of all credit items reported.
347	Total debits (SWIFT Code) The total of all debit items reported.
348	Booked amount on the account (SWIFT Code) Booked amount on the account.
349	Pending amount to be booked on account (SWIFT Code) The amount which is pending booking on a financial account.
350	Damage repair cost Cost incurred by repair of the damage.

**Used Codes**

357	Interim opening balance (SWIFT Code) The opening balance of a consecutive statement.
358	Interim closing balance (SWIFT Code) The closing balance of a consecutive statement.
359	Balance to be confirmed for audit reasons Balance to be confirmed for audit reasons.
360	Accrued debit interest (SWIFT Code) Accrued debit interest.
361	Accrued credit interest (SWIFT Code) Accrued credit interest.
369	Goods and services tax Amount charged as tax on goods and services.
388	Total amount including Value Added Tax (VAT) The total monetary amount which includes the Value Added Tax (VAT).
396	Total price subsidy value The total value of all price subsidies.
397	Advertising amount Amount related to advertising.
400	Rebate amount The amount of a rebate.
401	Debt financing charge A charge amount related to the financing of a debt.
402	Total retail value The total retail value of all products.
462	Annual turnover The annual turnover.
496	Total returnable packages deposit amount Total deposit amount for returnable packages.
497	Goods and services total amount excluding returnable goods Total amount of goods and services excluding deposits for returnable goods.
503	Contract total amount Total value of a contract.
505	Rental amount The amount to be paid for the right to use a place, product or service.
506	Gross-progress payment amount Gross monetary amount paid or to be paid at intervals.

**Used Codes**

507	Net-progress payment amount Net monetary amount paid or to be paid at intervals.
508	Value of returned product Value of product returned by the customer.
509	Unit allowance amount The monetary amount of an allowance for each unit.
526	Volume discount A discount for reaching or exceeding an agreed volume.
527	Product range discount Discount for the purchase of a whole range of products.
528	Calculation basis excluding all taxes The amount used as the basis for calculation excludes all taxes.
529	Calculation basis which includes all taxes except VAT The amount, used as the basis for calculation, which includes all taxes except Value Added Tax (VAT).
542	Unloading and handling cost Cost incurred by unloading and handling.
544	Taxable amount - excluding payment discount amount Indication of the total taxable amount before deducting payment discount amount.
545	Must buy product in multi-buy promotions value The value of a product which must be bought in order to qualify for the multi-buy promotion. GS1 Note: Replaces GS1 Temporary Code 29E.
546	Additional voluntary contribution amount Additional voluntary contribution amount paid by the employee. GS1 Note: Replaces GS1 Temporary Code 33E.
547	Interest amount over employee's obligatory contribution Interest amount calculated over the employee's obligatory contribution. GS1 Note: Replaces GS1 Temporary Code 34E. EDIFACT code added, replacing GS1 code 34E
548	Prepaid amount related to the obligatory contribution Prepaid amount related to the employee's obligatory contribution. GS1 Note: Replaces GS1 Temporary Code 39E.
549	Amount to be compensated between social security entities Amount which needs to be compensated between social security entities. GS1 Note: Replaces GS1 Temporary Code 40E.
550	Bank check amount Amount to be paid by bank check.



**Used Codes**

10E	Value of coins (GS1 Temporary Code) The amount of change which is given by cigarette vending machines.
28E	Financing allowance/charge (GS1 Temporary Code) A charge or allowance related to the financing of a debt.
29E	Multi-buy promotion value (GS1 Temporary Code) A value of a product included in a multi-buy promotion which must be purchased in order to qualify for the multi-buy promotion. GS1 Note: Code marked for deletion. Use value 545 instead.
32E	Exceptional situation amount (GS1 Temporary Code) Amount of the exceptional situation that affects the normal contribution of the employee in a given period.
33E	Additional voluntary contribution amount (GS1 Temporary Code) Additional voluntary contribution amount paid by the employee. GS1 Note: Code marked for deletion. Use value 546 instead.
34E	Interest amount over employee's obligatory contribution (GS1 Temporary Code) Interest amount calculated over the employee's obligatory contribution (GS1 Temporary Code) GS1 Note: Code marked for deletion. Use value 547 instead.
35E	Total returnable items deposit amount (GS1 Temporary Code) Total deposit amount for returnable items.
39E	Prepaid amount related to the obligatory contribution (GS1 Temporary Code) Prepaid amount related to the employee's obligatory contribution. GS1 Note: Code marked for deletion. Use value 548 instead.
40E	Amount to be compensated between social security entities (GS1 Temporary Code) Amount which needs to be compensated between social security entities. GS1 Note: Code marked for deletion. Use value 549 instead.
41E	Interest over solidarity fund (GS1 Temporary Code) Interest to pay because contribution to solidarity fund was not paid on time.
42E	Interest over employee additional contribution (GS1 Temporary Code) Interest to pay because contribution to employee additional contribution was not paid on time.
X41	Total returnable items rental fee amount (GS1 Temporary Code) Total rental fee amount for returnable items.
X42	Rental fee (GS1 Temporary Code) The amount charged for the rental of an item.
XB5	Information amount (SWIFT Code) A monetary amount provided for information purposes.

**Used Codes**

XB6	Beneficiary's account number unknown (SWIFT Code) The account number of the beneficiary is unknown.
<b>6069</b>	Control total type code qualifier Code qualifying the type of control of hash total.
1	Total value of the quantity segments at line level in a message Self-explanatory. GS1 Description: The total value of all QTY segments at line level within a message.
2	Number of line items in message Self-explanatory. GS1 Description: The total number of LIN segments in a message.
7	Total gross weight Code to indicate total gross weight of a consignment.
10	Total number of consignments The total number of consignments.
11	Total number of packages Total number of packages of the entire consignment.
15	Total consignment, cube The total cube of consignment.
16	Total number of equipment Total number of equipment mentioned in the message.
26	Total gross measurement/cube Total gross cubic measurement of the goods, including packing but excluding transport equipment.
27	Total number of credit items given for control purposes Total number of credit items given for control purposes.
28	Total number of debit items given for control purposes Total number of debit items given for control purposes.
29	Total net weight of consignment A code to indicate the total net weight of a consignment.
30	Total number of empty containers The total number of empty containers mentioned in the message.
31	Number of messages Control count of the number of messages referenced. GS1 Description: Control count of the number of messages or documents referenced.

## Used Codes

---

32	Total gross weight of the goods within the means of transport Weight (mass) of the goods within the means of transport, including packing and excluding the carrier's equipment.
40	Total number of sequence details in message The total number of sequence details in the message.
47	Total wholesaler unsold quantity Total quantity of unsold goods held by the wholesaler.
48	Total quantity held by delivery vehicles Total quantity held by the delivery vehicles.
49	Total quantity held by retail outlets Total quantity held by the retail outlets.
50	Total rejected return quantity The total quantity for return which have been rejected.
51	Number of goods items in the message The total number of goods items in a message. GS1 Description: The total number of GID segments in a message.
56	Total number of transport units Number of separate units of cargo handled during transportation of a consignment. EDIFACT
57	Total loading metres The total number of loading metres.
62	Number of premises A code to indicate the total number of premises detailed in the message. GS1 Note: Replaces GS1 Temporary Code 31E.
63	Number of meters The total number of meters. GS1 Note: Replaces GS1 Temporary Code 36E.
64	Total number of pallet places Total number of places needed to load the pallets of the entire consignment.
31E	Number of premises (GS1 Temporary Code) A code to indicate the total number of premises detailed in the message. GS1 Note: Code marked for deletion. Use value 62 instead.
36E	Number of meters (GS1 Temporary Code) The total number of meters within premises. GS1 Note: Code marked for deletion. Use value 63 instead.
<b>6341</b>	Exchange rate currency market identifier To identify an exchange rate currency market.

**Used Codes**

AMS	Amsterdam exchange The currency exchange rate is set by the Amsterdam exchange.
FRA	Frankfurt exchange The currency exchange rate is set by the Frankfurt exchange.
IMF	International Monetary Fund The currency exchange rate is set by the International Monetary Fund.
LNF	London exchange, first closing The currency exchange rate is set by the London exchange at the first closing.
LNS	London exchange, second closing The currency exchange rate is set by the London exchange at the second closing.
NYC	New York exchange The currency exchange rate is set by the New York exchange.
PHI	Philadelphia exchange The currency exchange rate is set by the Philadelphia exchange.
ZUR	Zurich exchange The currency exchange rate is set by the Zurich exchange.
<b>6343</b>	Currency type code qualifier Code qualifying the type of currency.
1	Customs valuation currency The name or symbol of the monetary unit involved in the transaction for customs valuation.
3	Home currency The name or symbol of the local monetary unit.
4	Invoicing currency The name or symbol of the monetary unit used for calculation in an invoice.
5	Account currency The name or symbol of the monetary unit to be converted from.
8	Price list currency The name or symbol of the monetary unit used in a price list.
9	Order currency The name or symbol of the monetary unit used in an order.
10	Pricing currency The name or symbol of the monetary unit used for pricing purposes.
11	Payment currency The name or symbol of the monetary unit used for payment.

**Used Codes**

12	Quotation currency The name or symbol of the monetary unit used in a quotation.
13	Recipient local currency The name or symbol of the local monetary unit at recipient's location.
14	Supplier currency The name or symbol of the monetary unit normally used by the supplier.
15	Sender local currency The name or symbol of the local monetary unit at sender's location.
17	Charge calculation currency The currency in which the charges are calculated.
18	Tax currency The currency in which tax amounts are due or have been paid. EDIFACT
<b>6345</b>	Currency identification code Code specifying a monetary unit.  Notes: 1. Use ISO 4217 three alpha code.
AED	Dirham
AFN	Afghani
ALL	Lek
AMD	Dram
ANG	Netherlands Antillian Guilder
AOA	Kwanza
ARS	Argentine Peso
AUD	Australian Dollar
AWG	Aruban Florin
AZN	Azerbaijan Manat
BAM	Convertible Mark
BBD	Barbados Dollar
BDT	Taka
BGN	Bulgarian Lev
BHD	Bahraini Dinar
BIF	Burundi Franc
BMD	Bermudian Dollar (customarily: Bermuda Dollar)

**Used Codes**

BND	Brunei Dollar
BOB	Boliviano
BOV	Mvdol
BRL	Brazilian Real
BSD	Bahamian Dollar
BTN	Ngultrum
BWP	Pula
BYN	Belarussian Ruble
BZD	Belize Dollar
CAD	Canadian Dollar
CDF	Franc Congolais
CHE	WIR Euro
CHF	Swiss Franc
CHW	WIR Franc
CLF	Unidad de Fomento
CLP	Chilean Peso
CNY	Yuan Renminbi
COP	Colombian Peso
COU	Unidad de Valor Real
CRC	Costa Rican Colon
CUC	Peso Convertible
CUP	Cuban Peso
CVE	Cabo Verde Escudo
CZK	Czech Koruna
DJF	Djibouti Franc
DKK	Danish Krone
DOP	Dominican Peso
DZD	Algerian Dinar
EGP	Egyptian Pound
ERN	Nakfa
ETB	Ethopian Birr
EUR	Euro
FJD	Fiji Dollar

**Used Codes**

FKP	Falkland Islands Pound
GBP	Pound Sterling
GEL	Lari
GHS	Ghana Cedi
GIP	Gibraltar Pound
GMD	Dalasi
GNF	Guinean Franc
GTQ	Quetzal
GYD	Guyana Dollar
HKD	Honk Kong Dollar
HNL	Lempira
HRK	Kuna
HTG	Gourde
HUF	Forint
IDR	Rupiah
ILS	New Israeli Sheqel
INR	Indian Rupee
IQD	Iraqi Dinar
IRR	Iranian Rial
ISK	Iceland Krona
JMD	Jamaican Dollar
JOD	Jordanian Dinar
JPY	Yen
KES	Kenyan Shilling
KGS	Som
KHR	Riel
KMF	Comorian Franc
KPW	North Korean Won
KRW	Won
KWD	Kuwaiti Dinar
KYD	Cayman Islands Dollar
KZT	Tenge
LAK	Lao Kip

**Used Codes**

LBP	Lebanese Pound
LKR	Sri Lanka Rupee
LRD	Liberian Dollar
LSL	Loti
LYD	Libyan Dinar
MAD	Moroccan Dirham
MDL	Moldovan Leu
MGA	Ariary
MKD	Denar
MMK	Kyat
MNT	Tugrik
MOP	Pataca
MRU	Ouguiya
MUR	Mauritius Rupee
MVR	Rufiyaa
MWK	Malawi Kwacha
MXN	Mexican Peso
MXV	Mexican Unidad de Inversion (UDI)
MYR	Malaysian Ringgit
MZN	Mozambique Metical
NAD	Namibia Dollar
NGN	Naira
NIO	Cordoba Oro
NOK	Norwegian Krone
NPR	Nepalese Rupee
NZD	New Zealand Dollar
OMR	Rial Omani
PAB	Balboa
PEN	Sol
PGK	Kina
PHP	Philippine Piso
PKR	Pakistan Rupee
PLN	Zloty



**Used Codes**

PYG	Guarani
QAR	Qatari Rial
RON	Romanian Leu This currency code is effective from 1 July 2005
RSD	Serbian Dinar
RUB	Russian Ruble
RWF	Rwanda Franc
SAR	Saudi Riyal
SBD	Solomon Islands Dollar
SCR	Seychelles Rupee
SDG	Sudanese Pound
SEK	Swedish Krona
SGD	Singapore Dollar
SHP	St. Helena Pound
SLL	Leone
SOS	Somali Shilling
SRD	Suriname Dollar
SSP	South Sudanese Pound
STN	Dobra
SVC	El Salvador Colon
SYP	Syrian Pound
SZL	Lilangeni
THB	Baht
TJS	Somoni
TMT	Turkmenistan New Manat
TND	Tunisian Dinar
TOP	Pa'anga
TRY	Turkish Lira
TTD	Trinidad and Tobago Dollar
TWD	New Taiwan Dollar
TZS	Tanzanian Shilling
UAH	Hryvnia
UGX	Uganda Shilling

**Used Codes**

USD	US Dollar
USN	US Dollar (Next day)
UYI	Uruguayo Peso en Unidades
UYU	Peso Uruguayo
UYW	Unidad Previsional
UZS	Uzbekistan Sum
VES	Bolívar Soberano
VND	Dong
VUV	Vatu
WST	Tala
XAF	CFA Franc
XAG	Silver
XAU	Gold
XBA	Bond Markets Units European Composite Unit (EURCO)
XBB	European Monetary Unit (E.M.U.-6)
XBC	European Unit of Account 9 (E.U.A.-9)
XBD	European Unit of Account 17 (E.U.A.-17)
XCD	East Carribean Dollar
XDR	SDR
XOF	CFA Franc
XPD	Palladium
XPF	CFP Franc
XPT	Platinum
XSU	Sucre
XTS	Codes specifically reserved for testing purposes
XUA	ADB Unit of Account
XXX	The codes assigned for transactions where no currency is involved
YER	Yemeni Rial
ZAR	Rand
ZMW	Zambian Kwacha
ZWL	Zimbabwe Dollar (effective 1 February 2009)

## Used Codes

---

<b>6347</b>	Currency usage code qualifier Code qualifying the usage of a currency.
2	Reference currency The currency applicable to amounts stated. It may have to be converted.
3	Target currency The currency which should be used to the target destination of the transaction.
<b>6411</b>	Measurement unit code Code specifying the unit of measurement.
	Notes:   1. Recommend use UN/ECE Recommendation 20, Common code.
10	group A unit of count defining the number of groups (group: set of items classified together).
11	outfit A unit of count defining the number of outfits (outfit: a complete set of equipment / materials / objects used for a specific purpose).
13	ration A unit of count defining the number of rations (ration: a single portion of provisions).
14	shot A unit of liquid measure, especially related to spirits.
15	stick, military A unit of count defining the number of military sticks (military stick: bombs or paratroops released in rapid succession from an aircraft).
20	twenty foot container A unit of count defining the number of shipping containers that measure 20 foot in length.
21	forty foot container A unit of count defining the number of shipping containers that measure 40 foot in length.
22	decilitre per gram
23	gram per cubic centimetre
24	theoretical pound A unit of mass defining the expected mass of material expressed as the number of pounds.
25	gram per square centimetre

**Used Codes**

27	theoretical ton A unit of mass defining the expected mass of material, expressed as the number of tons.
28	kilogram per square metre
33	kilopascal square metre per gram
34	kilopascal per millimetre
35	millilitre per square centimetre second
37	ounce per square foot
38	ounce per square foot per 0,01inch
40	millilitre per second
41	millilitre per minute
56	sitas A unit of area for tin plate equal to a surface area of 100 square metres.
57	mesh A unit of count defining the number of strands per inch as a measure of the fineness of a woven product.
58	net kilogram A unit of mass defining the total number of kilograms after deductions.
59	part per million A unit of proportion equal to 10 to the power of -6.
60	percent weight A unit of proportion equal to 10 to the power of -2.
61	part per billion (US) A unit of proportion equal to 10 to the power of -9.
64	pound per square inch, gauge
66	oersted
74	millipascal
76	gauss
77	milli-inch
78	kilogauss
80	pound per square inch absolute
81	henry
84	kilopound-force per square inch A unit of pressure defining the number of kilopounds force per square inch. Use kip per square inch (common code N20).
85	foot pound-force

**Used Codes**

87	pound per cubic foot
89	poise
91	stokes
1I	fixed rate A unit of quantity expressed as a predetermined or set rate for usage of a facility or service.
2A	radian per second Refer ISO/TC12 SI Guide
2B	radian per second squared Refer ISO/TC12 SI Guide
2C	roentgen
2G	volt AC A unit of electric potential in relation to alternating current (AC).
2H	volt DC A unit of electric potential in relation to direct current (DC).
2I	British thermal unit (international table) per hour
2J	cubic centimetre per second
2K	cubic foot per hour
2L	cubic foot per minute
2M	centimetre per second
2N	decibel
2P	kilobyte A unit of information equal to 10 to the power of 3 (1000) bytes.
2Q	kilobecquerel
2R	kilocurie
2U	megagram
2X	metre per minute
2Y	milliroentgen
2Z	millivolt
3B	megajoule
3C	manmonth A unit of count defining the number of months for a person or persons to perform an undertaking.
4C	centistokes
4G	microlitre

**Used Codes**

4H	micrometre (micron)
4K	milliampere
4L	megabyte A unit of information equal to 10 to the power of 6 (1000000) bytes.
4M	milligram per hour
4N	megabecquerel
4O	microfarad
4P	newton per metre
4Q	ounce inch
4R	ounce foot
4T	picofarad
4U	pound per hour
4W	ton (US) per hour
4X	kilolitre per hour
5A	barrel (US) per minute
5B	batch A unit of count defining the number of batches (batch: quantity of material produced in one operation or number of animals or persons coming at once).
5E	MMSCF/day A unit of volume equal to one million (1000000) cubic feet of gas per day.
5J	hydraulic horse power A unit of power defining the hydraulic horse power delivered by a fluid pump depending on the viscosity of the fluid.
A1	15 °C calorie
A10	ampere square metre per joule second
A11	angstrom
A12	astronomical unit
A13	attojoule
A14	barn
A15	barn per electronvolt
A16	barn per steradian electronvolt
A17	barn per steradian
A18	becquerel per kilogram
A19	becquerel per cubic metre
A2	ampere per centimetre

**Used Codes**

A20	British thermal unit (international table) per second square foot degree Rankine
A21	British thermal unit (international table) per pound degree Rankine
A22	British thermal unit (international table) per second foot degree Rankine
A23	British thermal unit (international table) per hour square foot degree Rankine
A24	candela per square metre
A25	cheval vapeur Synonym: metric horse power
A26	coulomb metre
A27	coulomb metre squared per volt
A28	coulomb per cubic centimetre
A29	coulomb per cubic metre
A3	ampere per millimetre
A30	coulomb per cubic millimetre
A31	coulomb per kilogram second
A32	coulomb per mole
A33	coulomb per square centimetre
A34	coulomb per square metre
A35	coulomb per square millimetre
A36	cubic centimetre per mole
A37	cubic decimetre per mole
A38	cubic metre per coulomb
A39	cubic metre per kilogram
A4	ampere per square centimetre
A40	cubic metre per mole
A41	ampere per square metre
A42	curie per kilogram
A43	deadweight tonnage A unit of mass defining the difference between the weight of a ship when completely empty and its weight when completely loaded, expressed as the number of tons.
A44	decalitre
A45	decametre

**Used Codes**

A47	decitex A unit of yarn density. One decitex equals a mass of 1 gram per 10 kilometres of length.
A48	degree Rankine Refer ISO 80000-5 (Quantities and units — Part 5: Thermodynamics)
A49	denier A unit of yarn density. One denier equals a mass of 1 gram per 9 kilometres of length.
A5	ampere square metre
A50	dyne second per cubic centimetre
A51	dyne second per centimetre
A52	dyne second per centimetre to the fifth power
A53	electronvolt
A54	electronvolt per metre
A55	electronvolt square metre
A56	electronvolt square metre per kilogram
A57	erg
A58	erg per centimetre
A59	8-part cloud cover A unit of count defining the number of eighth-parts as a measure of the celestial dome cloud coverage. Synonym: OKTA , OCTA
A6	ampere per square metre kelvin squared
A60	erg per cubic centimetre
A61	erg per gram
A62	erg per gram second
A63	erg per second
A64	erg per second square centimetre
A65	erg per square centimetre second
A66	erg square centimetre
A67	erg square centimetre per gram
A68	exajoule
A69	farad per metre
A7	ampere per square millimetre
A70	femtojoule



**Used Codes**

A71	femtometre
A73	foot per second squared
A74	foot pound-force per second
A75	freight ton A unit of information typically used for billing purposes, defined as either the number of metric tons or the number of cubic metres, whichever is the larger.
A76	gal
A77	Gaussian CGS (Centimetre-Gram-Second system) unit of displacement
A78	Gaussian CGS (Centimetre-Gram-Second system) unit of electric current
A79	Gaussian CGS (Centimetre-Gram-Second system) unit of electric charge
A8	ampere second
A80	Gaussian CGS (Centimetre-Gram-Second system) unit of electric field strength
A81	Gaussian CGS (Centimetre-Gram-Second system) unit of electric polarization
A82	Gaussian CGS (Centimetre-Gram-Second system) unit of electric potential
A83	Gaussian CGS (Centimetre-Gram-Second system) unit of magnetization
A84	gigacoulomb per cubic metre
A85	gigaelectronvolt
A86	gigahertz
A87	gigaohm
A88	gigaohm metre
A89	gigapascal
A9	rate A unit of quantity expressed as a rate for usage of a facility or service.
A90	gigawatt
A91	gon Synonym: grade
A93	gram per cubic metre
A94	gram per mole
A95	gray
A96	gray per second
A97	hectopascal
A98	henry per metre
A99	bit A unit of information equal to one binary digit.

**Used Codes**

AA	ball A unit of count defining the number of balls (ball: object formed in the shape of sphere).
AB	bulk pack A unit of count defining the number of items per bulk pack.
ACR	acre
ACT	activity A unit of count defining the number of activities (activity: a unit of work or action).
AD	byte A unit of information equal to 8 bits.
AE	ampere per metre
AH	additional minute A unit of time defining the number of minutes in addition to the referenced minutes.
AI	average minute per call A unit of count defining the number of minutes for the average interval of a call.
AK	fathom
AL	access line A unit of count defining the number of telephone access lines.
AMH	ampere hour A unit of electric charge defining the amount of charge accumulated by a steady flow of one ampere for one hour.
AMP	ampere
ANN	year Unit of time equal to 365,25 days. Synonym: Julian year
APZ	troy ounce or apothecary ounce
AQ	anti-hemophilic factor (AHF) unit A unit of measure for blood potency (US).
ARE	are Synonym: square decametre
AS	assortment A unit of count defining the number of assortments (assortment: set of items grouped in a mixed collection).
ASM	alcoholic strength by mass A unit of mass defining the alcoholic strength of a liquid.

**Used Codes**

ASU	alcoholic strength by volume A unit of volume defining the alcoholic strength of a liquid (e.g. spirit, wine, beer, etc), often at a specific temperature.
ATM	standard atmosphere
ATT	technical atmosphere
AWG	american wire gauge A unit of distance used for measuring the diameter of small tubes or wires such as the outer diameter of hypotermic or suture needles.
AY	assembly A unit of count defining the number of assemblies (assembly: items that consist of component parts).
AZ	British thermal unit (international table) per pound
B1	barrel (US) per day
B10	bit per second A unit of information equal to one binary digit per second.
B11	joule per kilogram kelvin
B12	joule per metre
B13	joule per square metre Synonym: joule per metre squared
B14	joule per metre to the fourth power
B15	joule per mole
B16	joule per mole kelvin
B17	credit A unit of count defining the number of entries made to the credit side of an account.
B18	joule second
B19	digit A unit of information defining the quantity of numerals used to form a number.
B20	joule square metre per kilogram
B21	kelvin per watt
B22	kiloampere
B23	kiloampere per square metre
B24	kiloampere per metre
B25	kilobecquerel per kilogram
B26	kilocoulomb
B27	kilocoulomb per cubic metre

**Used Codes**

B28	kilocoulomb per square metre
B29	kiloelectronvolt
B3	batting pound A unit of mass defining the number of pounds of wadded fibre.
B30	gibibit A unit of information equal to 2 <sup>30</sup> bits (binary digits).
B31	kilogram metre per second
B32	kilogram metre squared
B33	kilogram metre squared per second
B34	kilogram per cubic decimetre
B35	kilogram per litre
B36	calorie (thermochemical) per gram
B37	kilogram-force
B38	kilogram-force metre
B39	kilogram-force metre per second
B4	barrel, imperial A unit of volume used to measure beer. One beer barrel equals 36 imperial gallons.
B40	kilogram-force per square metre
B41	kilojoule per kelvin
B42	kilojoule per kilogram
B43	kilojoule per kilogram kelvin
B44	kilojoule per mole
B45	kilomole
B46	kilomole per cubic metre
B47	kilonewton
B48	kilonewton metre
B49	kiloohm
B50	kiloohm metre
B51	kilopond Synonym: kilogram-force
B52	kilosecond
B53	kilosiemens
B54	kilosiemens per metre

**Used Codes**

B55	kilovolt per metre
B56	kiloweber per metre
B57	light year A unit of length defining the distance that light travels in a vacuum in one year.
B58	litre per mole
B59	lumen hour
B60	lumen per square metre
B61	lumen per watt
B62	lumen second
B63	lux hour
B64	lux second
B65	maxwell
B66	megaampere per square metre
B67	megabecquerel per kilogram
B68	gigabit A unit of information equal to 10 to the power of 9 bits (binary digits).
B69	megacoulomb per cubic metre
B7	cycle A unit of count defining the number of cycles (cycle: a recurrent period of definite duration).
B70	megacoulomb per square metre
B71	megaelectronvolt
B72	megagram per cubic metre
B73	meganewton
B74	meganewton metre
B75	megaohm
B76	megaohm metre
B77	megasiemens per metre
B78	megavolt
B79	megavolt per metre
B8	joule per cubic metre
B80	gigabit per second A unit of information equal to 10 to the power of 9 bits (binary digits) per second.

**Used Codes**

B81	reciprocal metre squared reciprocal second
B82	inch per linear foot A unit of length defining the number of inches per linear foot.
B83	metre to the fourth power
B84	microampere
B85	microbar
B86	microcoulomb
B87	microcoulomb per cubic metre
B88	microcoulomb per square metre
B89	microfarad per metre
B90	microhenry
B91	microhenry per metre
B92	micronewton
B93	micronewton metre
B94	microohm
B95	microohm metre
B96	micropascal
B97	microradian
B98	microsecond
B99	microsiemens
BAR	bar [unit of pressure]
BB	base box A unit of area of 112 sheets of tin mil products (tin plate, tin free steel or black plate) 14 by 20 inches, or 31,360 square inches.
BFT	board foot A unit of volume defining the number of cords (cord: a stack of firewood of 128 cubic feet).
BHP	brake horse power
BIL	billion (EUR) Synonym: trillion (US)
BLD	dry barrel (US)
BLL	barrel (US)
BP	hundred board foot A unit of volume equal to one hundred board foot.

**Used Codes**

BPM	beats per minute The number of beats per minute.
BQL	becquerel
BTU	British thermal unit (international table)
BUA	bushel (US)
BUI	bushel (UK)
C0	call A unit of count defining the number of calls (call: communication session or visitation).
C10	millifarad
C11	milligal
C12	milligram per metre
C13	milligray
C14	millihenry
C15	millijoule
C16	millimetre per second
C17	millimetre squared per second
C18	millimole
C19	mole per kilogram
C20	millinewton
C21	kibibit A unit of information equal to 2 to the power of 10 (1024) bits (binary digits).
C22	millinewton per metre
C23	milliohm metre
C24	millipascal second
C25	milliradian
C26	millisecond
C27	millisiemens
C28	millisievert
C29	millitesla
C3	microvolt per metre
C30	millivolt per metre
C31	milliwatt
C32	milliwatt per square metre

**Used Codes**

C33	milliweber
C34	mole
C35	mole per cubic decimetre
C36	mole per cubic metre
C37	kilobit A unit of information equal to 10 to the power of 3 (1000) bits (binary digits).
C38	mole per litre
C39	nanoampere
C40	nanocoulomb
C41	nanofarad
C42	nanofarad per metre
C43	nanohenry
C44	nanohenry per metre
C45	nanometre
C46	nanoohm metre
C47	nanosecond
C48	nanotesla
C49	nanowatt
C50	neper
C51	neper per second
C52	picometre
C53	newton metre second
C54	newton metre squared per kilogram squared
C55	newton per square metre
C56	newton per square millimetre
C57	newton second
C58	newton second per metre
C59	octave A unit used in music to describe the ratio in frequency between notes.
C60	ohm centimetre
C61	ohm metre
C62	one Synonym: unit
C63	parsec



**Used Codes**

C64	pascal per kelvin
C65	pascal second
C66	pascal second per cubic metre
C67	pascal second per metre
C68	petajoule
C69	phon A unit of subjective sound loudness. A sound has loudness $p$ phons if it seems to the listener to be equal in loudness to the sound of a pure tone of frequency 1 kilohertz and strength $p$ decibels.
C7	centipoise
C70	picoampere
C71	picocoulomb
C72	picofarad per metre
C73	picohenry
C74	kilobit per second A unit of information equal to 10 to the power of 3 (1000) bits (binary digits) per second.
C75	picowatt
C76	picowatt per square metre
C78	pound-force
C79	kilovolt ampere hour A unit of accumulated energy of 1000 volt amperes over a period of one hour.
C8	millicoulomb per kilogram
C80	rad
C81	radian
C82	radian square metre per mole
C83	radian square metre per kilogram
C84	radian per metre
C85	reciprocal angstrom
C86	reciprocal cubic metre
C87	reciprocal cubic metre per second Synonym: reciprocal second per cubic metre
C88	reciprocal electron volt per cubic metre
C89	reciprocal henry

## Used Codes

---

C9	coil group A unit of count defining the number of coil groups (coil group: groups of items arranged by lengths of those items placed in a joined sequence of concentric circles).
C90	reciprocal joule per cubic metre
C91	reciprocal kelvin or kelvin to the power minus one
C92	reciprocal metre
C93	reciprocal square metre Synonym: reciprocal metre squared
C94	reciprocal minute
C95	reciprocal mole
C96	reciprocal pascal or pascal to the power minus one
C97	reciprocal second
C99	reciprocal second per metre squared
CCT	carrying capacity in metric ton A unit of mass defining the carrying capacity, expressed as the number of metric tons.
CDL	candela
CEL	degree Celsius Refer ISO 80000-5 (Quantities and units — Part 5: Thermodynamics)
CEN	hundred A unit of count defining the number of units in multiples of 100.
CG	card A unit of count defining the number of units of card (card: thick stiff paper or cardboard).
CGM	centigram
CKG	coulomb per kilogram
CLF	hundred leave A unit of count defining the number of leaves, expressed in units of one hundred leaves.
CLT	centilitre
CMK	square centimetre
CMQ	cubic centimetre
CMT	centimetre
CNP	hundred pack A unit of count defining the number of hundred-packs (hundred-pack: set of one hundred items packaged together).

**Used Codes**

CNT	cental (UK) A unit of mass equal to one hundred weight (US).
COU	coulomb
CTG	content gram A unit of mass defining the number of grams of a named item in a product.
CTM	metric carat
CTN	content ton (metric) A unit of mass defining the number of metric tons of a named item in a product.
CUR	curie
CWA	hundred pound (cwt) / hundred weight (US)
CWI	hundred weight (UK)
D03	kilowatt hour per hour A unit of accumulated energy of a thousand watts over a period of one hour.
D04	lot [unit of weight] A unit of weight equal to about 1/2 ounce or 15 grams.
D1	reciprocal second per steradian
D10	siemens per metre
D11	mebibit A unit of information equal to 2 to the power of 20 (1048576) bits (binary digits).
D12	siemens square metre per mole
D13	sievert
D15	sone A unit of subjective sound loudness. One sone is the loudness of a pure tone of frequency one kilohertz and strength 40 decibels.
D16	square centimetre per erg
D17	square centimetre per steradian erg
D18	metre kelvin
D19	square metre kelvin per watt
D2	reciprocal second per steradian metre squared
D20	square metre per joule
D21	square metre per kilogram
D22	square metre per mole

**Used Codes**

D23	pen gram (protein) A unit of count defining the number of grams of amino acid prescribed for parenteral/enteral therapy.
D24	square metre per steradian
D25	square metre per steradian joule
D26	square metre per volt second
D27	steradian
D29	terahertz
D30	terajoule
D31	terawatt
D32	terawatt hour
D33	tesla
D34	tex A unit of yarn density. One decitex equals a mass of 1 gram per 1 kilometre of length.
D35	calorie (thermochemical)
D36	megabit A unit of information equal to 10 to the power of 6 (1000000) bits (binary digits).
D37	calorie (thermochemical) per gram kelvin
D38	calorie (thermochemical) per second centimetre kelvin
D39	calorie (thermochemical) per second square centimetre kelvin
D41	tonne per cubic metre
D42	tropical year
D43	unified atomic mass unit
D44	var The name of the unit is an acronym for volt-ampere-reactive.
D45	volt squared per kelvin squared
D46	volt - ampere
D47	volt per centimetre
D48	volt per kelvin
D49	millivolt per kelvin
D5	kilogram per square centimetre
D50	volt per metre
D51	volt per millimetre

**Used Codes**

D52	watt per kelvin
D53	watt per metre kelvin
D54	watt per square metre
D55	watt per square metre kelvin
D56	watt per square metre kelvin to the fourth power
D57	watt per steradian
D58	watt per steradian square metre
D59	weber per metre
D6	roentgen per second
D60	weber per millimetre
D61	minute [unit of angle]
D62	second [unit of angle]
D63	book A unit of count defining the number of books (book: set of items bound together or written document of a material whole).
D65	round A unit of count defining the number of rounds (round: A circular or cylindrical object).
D68	number of words A unit of count defining the number of words.
D69	inch to the fourth power
D70	calorie (international table)
D71	calorie (international table) per second centimetre kelvin
D72	calorie (international table) per second square centimetre kelvin
D73	joule square metre
D74	kilogram per mole
D75	calorie (international table) per gram
D76	calorie (international table) per gram kelvin
D77	megacoulomb
D78	megajoule per second A unit of accumulated energy equal to one million joules per second.
D80	microwatt
D81	microtesla
D82	microvolt
D83	millinewton metre

**Used Codes**

D85	microwatt per square metre
D86	millicoulomb
D87	millimole per kilogram
D88	millicoulomb per cubic metre
D89	millicoulomb per square metre
D9	dyne per square centimetre
D91	rem
D93	second per cubic metre
D94	second per cubic metre radian
D95	joule per gram
DAA	decare
DAD	ten day A unit of time defining the number of days in multiples of 10.
DAY	day
DB	dry pound A unit of mass defining the number of pounds of a product, disregarding the water content of the product.
DBM	Decibel-milliwatts dBm (sometimes dBmW or decibel-milliwatts) is unit of level used to indicate that a power ratio is expressed in decibels (dB) with reference to one milliwatt (mW).
DBW	Decibel watt The decibel watt or dBW is a unit for the measurement of the strength of a signal expressed in decibels relative to one watt.
DD	degree [unit of angle]
DEC	decade A unit of count defining the number of decades (decade: quantity equal to 10 or time equal to 10 years).
DG	decigram
DJ	decagram
DLT	decilitre
DMA	cubic decametre
DMK	square decimetre
DMO	standard kilolitre A unit of volume defining the number of kilolitres of a product at a temperature of 15 degrees Celsius, especially in relation to hydrocarbon oils.
DMQ	cubic decimetre

**Used Codes**

DMT	decimetre
DN	decinewton metre
DPC	dozen piece A unit of count defining the number of pieces in multiples of 12 (piece: a single item, article or exemplar).
DPR	dozen pair A unit of count defining the number of pairs in multiples of 12 (pair: item described by two's).
DPT	displacement tonnage A unit of mass defining the volume of sea water a ship displaces, expressed as the number of tons.
DRA	dram (US) Synonym: drachm (UK), troy dram
DRI	dram (UK) Synonym: avoirdupois dram
DRL	dozen roll A unit of count defining the number of rolls, expressed in twelve roll units.
DT	dry ton A unit of mass defining the number of tons of a product, disregarding the water content of the product.
DTN	decitonne Synonym: centner, metric 100 kg, quintal, metric 100 kg
DU	dyne
DWT	pennyweight
DX	dyne per centimetre
DZN	dozen A unit of count defining the number of units in multiples of 12.
DZP	dozen pack A unit of count defining the number of packs in multiples of 12 (pack: standard packaging unit).
E01	newton per square centimetre A measure of pressure expressed in newtons per square centimetre.
E07	megawatt hour per hour A unit of accumulated energy of a million watts over a period of one hour.
E08	megawatt per hertz A unit of energy expressed as the load change in million watts that will cause a frequency shift of one hertz.

## Used Codes

E09	milliampere hour A unit of power load delivered at the rate of one thousandth of an ampere over a period of one hour.
E10	degree day A unit of measure used in meteorology and engineering to measure the demand for heating or cooling over a given period of days.
E11	gigacalorie A unit of heat energy equal to one thousand million calories.
E12	mille A unit of count defining the number of cigarettes in units of 1000.
E14	kilocalorie (international table) A unit of heat energy equal to one thousand calories.
E15	kilocalorie (thermochemical) per hour A unit of energy equal to one thousand calories per hour.
E16	million Btu(IT) per hour A unit of power equal to one million British thermal units per hour.
E17	cubic foot per second A unit of volume equal to one cubic foot passing a given point in a period of one second.
E18	tonne per hour A unit of weight or mass equal to one tonne per hour.
E19	ping A unit of area equal to 3.3 square metres.
E20	megabit per second A unit of information equal to 10 to the power of 6 (1000000) bits (binary digits) per second.
E21	shares A unit of count defining the number of shares (share: a total or portion of the parts into which a business entity's capital is divided).
E22	TEU A unit of count defining the number of twenty-foot equivalent units (TEUs) as a measure of containerized cargo capacity.
E23	tyre A unit of count defining the number of tyres (a solid or air-filled covering placed around a wheel rim to form a soft contact with the road, absorb shock and provide traction).
E25	active unit A unit of count defining the number of active units within a substance.



**Used Codes**

E27	dose A unit of count defining the number of doses (dose: a definite quantity of a medicine or drug).
E28	air dry ton A unit of mass defining the number of tons of a product, disregarding the water content of the product.
E30	strand A unit of count defining the number of strands (strand: long, thin, flexible, single thread, strip of fibre, constituent filament or multiples of the same, twisted together).
E31	square metre per litre A unit of count defining the number of square metres per litre.
E32	litre per hour A unit of count defining the number of litres per hour.
E33	foot per thousand A unit of count defining the number of feet per thousand units.
E34	gigabyte A unit of information equal to 10 to the power of 9 bytes.
E35	terabyte A unit of information equal to 10 to the power of 12 bytes.
E36	petabyte A unit of information equal to 10 to the power of 15 bytes.
E37	pixel A unit of count defining the number of pixels (pixel: picture element).
E38	megapixel A unit of count equal to 10 to the power of 6 (1000000) pixels (picture elements).
E39	dots per inch A unit of information defining the number of dots per linear inch as a measure of the resolution or sharpness of a graphic image.
E4	gross kilogram A unit of mass defining the total number of kilograms before deductions.
E40	part per hundred thousand A unit of proportion equal to 10 to the power of -5.
E41	kilogram-force per square millimetre A unit of pressure defining the number of kilograms force per square millimetre.

**Used Codes**

E42	kilogram-force per square centimetre A unit of pressure defining the number of kilograms force per square centimetre.
E43	joule per square centimetre A unit of energy defining the number of joules per square centimetre.
E44	kilogram-force metre per square centimetre A unit of torsion defining the torque kilogram-force metre per square centimetre.
E45	milliohm
E46	kilowatt hour per cubic metre A unit of energy consumption expressed as kilowatt hour per cubic metre.
E47	kilowatt hour per kelvin A unit of energy consumption expressed as kilowatt hour per kelvin.
E48	service unit A unit of count defining the number of service units (service unit: defined period / property / facility / utility of supply).
E49	working day A unit of count defining the number of working days (working day: a day on which work is ordinarily performed).
E50	accounting unit A unit of count defining the number of accounting units.
E51	job A unit of count defining the number of jobs.
E52	run foot A unit of count defining the number feet per run.
E53	test A unit of count defining the number of tests.
E54	trip A unit of count defining the number of trips.
E55	use A unit of count defining the number of times an object is used.
E56	well A unit of count defining the number of wells.
E57	zone A unit of count defining the number of zones.
E58	exabit per second A unit of information equal to 10 to the power of 18 bits (binary digits) per second.

**Used Codes**

E59	exbibyte A unit of information equal to 2 to the power of 60 bytes.
E60	pebibyte A unit of information equal to 2 to the power of 50 bytes.
E61	tebibyte A unit of information equal to 2 to the power of 40 bytes.
E62	gibibyte A unit of information equal to 2 to the power of 30 bytes.
E63	mebibyte A unit of information equal to 2 to the power of 20 bytes.
E64	kibibyte A unit of information equal to 2 to the power of 10 bytes.
E65	exbibit per metre A unit of information equal to 2 to the power of 60 bits (binary digits) per metre.
E66	exbibit per square metre A unit of information equal to 2 to the power of 60 bits (binary digits) per square metre.
E67	exbibit per cubic metre A unit of information equal to 2 to the power of 60 bits (binary digits) per cubic metre.
E68	gigabyte per second A unit of information equal to 10 to the power of 9 bytes per second.
E69	gibibit per metre A unit of information equal to 2 to the power of 30 bits (binary digits) per metre.
E70	gibibit per square metre A unit of information equal to 2 to the power of 30 bits (binary digits) per square metre.
E71	gibibit per cubic metre A unit of information equal to 2 to the power of 30 bits (binary digits) per cubic metre.
E72	kibibit per metre A unit of information equal to 2 to the power of 10 bits (binary digits) per metre.
E73	kibibit per square metre A unit of information equal to 2 to the power of 10 bits (binary digits) per square metre.

## Used Codes

---

E74	kibibit per cubic metre A unit of information equal to 2 to the power of 10 bits (binary digits) per cubic metre.
E75	mebibit per metre A unit of information equal to 2 to the power of 20 bits (binary digits) per metre.
E76	mebibit per square metre A unit of information equal to 2 to the power of 20 bits (binary digits) per square metre.
E77	mebibit per cubic metre A unit of information equal to 2 to the power of 20 bits (binary digits) per cubic metre.
E78	petabit A unit of information equal to 10 to the power of 15 bits (binary digits).
E79	petabit per second A unit of information equal to 10 to the power of 15 bits (binary digits) per second.
E80	pebibit per metre A unit of information equal to 2 to the power of 50 bits (binary digits) per metre.
E81	pebibit per square metre A unit of information equal to 2 to the power of 50 bits (binary digits) per square metre.
E82	pebibit per cubic metre A unit of information equal to 2 to the power of 50 bits (binary digits) per cubic metre.
E83	terabit A unit of information equal to 10 to the power of 12 bits (binary digits).
E84	terabit per second A unit of information equal to 10 to the power of 12 bits (binary digits) per second.
E85	tebibit per metre A unit of information equal to 2 to the power of 40 bits (binary digits) per metre.
E86	tebibit per cubic metre A unit of information equal to 2 to the power of 40 bits (binary digits) per cubic metre.
E87	tebibit per square metre A unit of information equal to 2 to the power of 40 bits (binary digits) per square metre.

**Used Codes**

E88	bit per metre A unit of information equal to 1 bit (binary digit) per metre.
E89	bit per square metre A unit of information equal to 1 bit (binary digit) per square metre.
E90	reciprocal centimetre
E91	reciprocal day
E92	cubic decimetre per hour
E93	kilogram per hour
E94	kilomole per second
E95	mole per second
E96	degree per second
E97	millimetre per degree Celcius metre
E98	degree Celsius per kelvin
E99	hectopascal per bar
EA	each A unit of count defining the number of items regarded as separate units.
EB	electronic mail box A unit of count defining the number of electronic mail boxes.
EQ	equivalent gallon A unit of volume defining the number of gallons of product produced from concentrate.
F01	bit per cubic metre A unit of information equal to 1 bit (binary digit) per cubic metre.
F02	kelvin per kelvin
F03	kilopascal per bar
F04	millibar per bar
F05	megapascal per bar
F06	poise per bar
F07	pascal per bar
F08	milliampere per inch
F10	kelvin per hour
F11	kelvin per minute
F12	kelvin per second

## Used Codes

---

F13	slug A unit of mass. One slug is the mass accelerated at 1 foot per second per second by a force of 1 pound.
F14	gram per kelvin
F15	kilogram per kelvin
F16	milligram per kelvin
F17	pound-force per foot
F18	kilogram square centimetre
F19	kilogram square millimetre
F20	pound inch squared
F21	pound-force inch
F22	pound-force foot per ampere
F23	gram per cubic decimetre
F24	kilogram per kilomole
F25	gram per hertz
F26	gram per day
F27	gram per hour
F28	gram per minute
F29	gram per second
F30	kilogram per day
F31	kilogram per minute
F32	milligram per day
F33	milligram per minute
F34	milligram per second
F35	gram per day kelvin
F36	gram per hour kelvin
F37	gram per minute kelvin
F38	gram per second kelvin
F39	kilogram per day kelvin
F40	kilogram per hour kelvin
F41	kilogram per minute kelvin
F42	kilogram per second kelvin
F43	milligram per day kelvin
F44	milligram per hour kelvin

**Used Codes**

F45	milligram per minute kelvin
F46	milligram per second kelvin
F47	newton per millimetre
F48	pound-force per inch
F49	rod [unit of distance] A unit of distance equal to 5.5 yards (16 feet 6 inches).
F50	micrometre per kelvin
F51	centimetre per kelvin
F52	metre per kelvin
F53	millimetre per kelvin
F54	milliohm per metre
F55	ohm per mile (statute mile)
F56	ohm per kilometre
F57	milliampere per pound-force per square inch
F58	reciprocal bar
F59	milliampere per bar
F60	degree Celsius per bar
F61	kelvin per bar
F62	gram per day bar
F63	gram per hour bar
F64	gram per minute bar
F65	gram per second bar
F66	kilogram per day bar
F67	kilogram per hour bar
F68	kilogram per minute bar
F69	kilogram per second bar
F70	milligram per day bar
F71	milligram per hour bar
F72	milligram per minute bar
F73	milligram per second bar
F74	gram per bar
F75	milligram per bar
F76	milliampere per millimetre

**Used Codes**

F77	pascal second per kelvin
F78	inch of water
F79	inch of mercury
F80	water horse power A unit of power defining the amount of power required to move a given volume of water against acceleration of gravity to a specified elevation (pressure head).
F81	bar per kelvin
F82	hectopascal per kelvin
F83	kilopascal per kelvin
F84	millibar per kelvin
F85	megapascal per kelvin
F86	poise per kelvin
F87	volt per litre minute
F88	newton centimetre
F89	newton metre per degree
F90	newton metre per ampere
F91	bar litre per second
F92	bar cubic metre per second
F93	hectopascal litre per second
F94	hectopascal cubic metre per second
F95	millibar litre per second
F96	millibar cubic metre per second
F97	megapascal litre per second
F98	megapascal cubic metre per second
F99	pascal litre per second
FAH	degree Fahrenheit Refer ISO 80000-5 (Quantities and units — Part 5: Thermodynamics)
FAR	farad
FBM	fibre metre A unit of length defining the number of metres of individual fibre.
FC	thousand cubic foot A unit of volume equal to one thousand cubic foot.
FF	hundred cubic metre A unit of volume equal to one hundred cubic metres.



## Used Codes

---

FH	micromole
FIT	failures in time A unit of count defining the number of failures that can be expected over a specified time interval. Failure rates of semiconductor components are often specified as FIT (failures in time unit) where 1 FIT = 10 to the power of -9 /h.
FL	flake ton A unit of mass defining the number of tons of a flaked substance (flake: a small flattish fragment).
FNU	Formazin nephelometric unit Formazin nephelometric unit (FNU) is used for water turbidity level evaluation
FOT	foot
FP	pound per square foot
FR	foot per minute
FS	foot per second
FTK	square foot
FTQ	cubic foot
G01	pascal cubic metre per second
G04	centimetre per bar
G05	metre per bar
G06	millimetre per bar
G08	square inch per second
G09	square metre per second kelvin
G10	stokes per kelvin
G11	gram per cubic centimetre bar
G12	gram per cubic decimetre bar
G13	gram per litre bar
G14	gram per cubic metre bar
G15	gram per millilitre bar
G16	kilogram per cubic centimetre bar
G17	kilogram per litre bar
G18	kilogram per cubic metre bar
G19	newton metre per kilogram
G2	US gallon per minute
G20	pound-force foot per pound
G21	cup [unit of volume]

**Used Codes**

G23	peck
G24	tablespoon (US)
G25	teaspoon (US)
G26	stere
G27	cubic centimetre per kelvin
G28	litre per kelvin
G29	cubic metre per kelvin
G3	Imperial gallon per minute
G30	millilitre per kelvin
G31	kilogram per cubic centimetre
G32	ounce (avoirdupois) per cubic yard
G33	gram per cubic centimetre kelvin
G34	gram per cubic decimetre kelvin
G35	gram per litre kelvin
G36	gram per cubic metre kelvin
G37	gram per millilitre kelvin
G38	kilogram per cubic centimetre kelvin
G39	kilogram per litre kelvin
G40	kilogram per cubic metre kelvin
G41	square metre per second bar
G42	microsiemens per centimetre
G43	microsiemens per metre
G44	nanosiemens per centimetre
G45	nanosiemens per metre
G46	stokes per bar
G47	cubic centimetre per day
G48	cubic centimetre per hour
G49	cubic centimetre per minute
G50	gallon (US) per hour
G51	litre per second
G52	cubic metre per day
G53	cubic metre per minute
G54	millilitre per day

**Used Codes**

G55	millilitre per hour
G56	cubic inch per hour
G57	cubic inch per minute
G58	cubic inch per second
G59	milliampere per litre minute
G60	volt per bar
G61	cubic centimetre per day kelvin
G62	cubic centimetre per hour kelvin
G63	cubic centimetre per minute kelvin
G64	cubic centimetre per second kelvin
G65	litre per day kelvin
G66	litre per hour kelvin
G67	litre per minute kelvin
G68	litre per second kelvin
G69	cubic metre per day kelvin
G70	cubic metre per hour kelvin
G71	cubic metre per minute kelvin
G72	cubic metre per second kelvin
G73	millilitre per day kelvin
G74	millilitre per hour kelvin
G75	millilitre per minute kelvin
G76	millilitre per second kelvin
G77	millimetre to the fourth power
G78	cubic centimetre per day bar
G79	cubic centimetre per hour bar
G80	cubic centimetre per minute bar
G81	cubic centimetre per second bar
G82	litre per day bar
G83	litre per hour bar
G84	litre per minute bar
G85	litre per second bar
G86	cubic metre per day bar
G87	cubic metre per hour bar

## Used Codes

G88	cubic metre per minute bar
G89	cubic metre per second bar
G90	millilitre per day bar
G91	millilitre per hour bar
G92	millilitre per minute bar
G93	millilitre per second bar
G94	cubic centimetre per bar
G95	litre per bar
G96	cubic metre per bar
G97	millilitre per bar
G98	microhenry per kilohm
G99	microhenry per ohm
GB	gallon (US) per day
GBQ	gigabecquerel
GDW	gram, dry weight A unit of mass defining the number of grams of a product, disregarding the water content of the product.
GE	pound per gallon (US)
GF	gram per metre (gram per 100 centimetres)
GFI	gram of fissile isotope A unit of mass defining the number of grams of a fissile isotope (fissile isotope: an isotope whose nucleus is able to be split when irradiated with low energy neutrons).
GGR	great gross A unit of count defining the number of units in multiples of 1728 (12 x 12 x 12).
GIA	gill (US)
GIC	gram, including container A unit of mass defining the number of grams of a product, including its container.
GII	gill (UK)
GIP	gram, including inner packaging A unit of mass defining the number of grams of a product, including its inner packaging materials.
GJ	gram per millilitre
GL	gram per litre

**Used Codes**

GLD	dry gallon (US)
GLI	gallon (UK)
GLL	gallon (US)
GM	gram per square metre
GO	milligram per square metre
GP	milligram per cubic metre
GQ	microgram per cubic metre
GRM	gram
GRN	grain
GRO	gross A unit of count defining the number of units in multiples of 144 (12 x 12).
GRT	gross register ton A unit of mass equal to the total cubic footage before deductions, where 1 register ton is equal to 100 cubic feet. Refer International Convention on tonnage measurement of ships.
GT	gross ton A unit of mass equal to 2240 pounds. Refer International Convention on Tonnage measurement of Ships. Synonym: ton (UK) or long ton (US) (common code LTN)
GV	gigajoule
GWH	gigawatt hour
H03	henry per kilohm
H04	henry per ohm
H05	millihenry per kilohm
H06	millihenry per ohm
H07	pascal second per bar
H08	microbecquerel
H09	reciprocal year
H10	reciprocal hour
H11	reciprocal month
H12	degree Celsius per hour
H13	degree Celsius per minute
H14	degree Celsius per second
H15	square centimetre per gram

**Used Codes**

H16	square decametre Synonym: are
H18	square hectometre Synonym: hectare
H19	cubic hectometre
H20	cubic kilometre
H21	blank A unit of count defining the number of blanks.
H22	volt square inch per pound-force
H23	volt per inch
H24	volt per microsecond
H25	percent per kelvin A unit of proportion, equal to 0.01, in relation to the SI base unit Kelvin.
H26	ohm per metre
H27	degree per metre
H28	microfarad per kilometre
H29	microgram per litre
H30	square micrometre (square micron)
H31	ampere per kilogram
H32	ampere squared second
H33	farad per kilometre
H34	hertz metre
H35	kelvin metre per watt
H36	megaohm per kilometre
H37	megaohm per metre
H38	megaampere
H39	megahertz kilometre
H40	newton per ampere
H41	newton metre watt to the power minus 0,5
H42	pascal per metre
H43	siemens per centimetre
H44	teraohm
H45	volt second per metre
H46	volt per second

**Used Codes**

H47	watt per cubic metre
H48	attofarad
H49	centimetre per hour
H50	reciprocal cubic centimetre
H51	decibel per kilometre
H52	decibel per metre
H53	kilogram per bar
H54	kilogram per cubic decimetre kelvin
H55	kilogram per cubic decimetre bar
H56	kilogram per square metre second
H57	inch per two pi radiant
H58	metre per volt second
H59	square metre per newton
H60	cubic metre per cubic metre
H61	millisiemens per centimetre
H62	millivolt per minute
H63	milligram per square centimetre
H64	milligram per gram
H65	millilitre per cubic metre
H66	millimetre per year
H67	millimetre per hour
H68	millimole per gram
H69	picopascal per kilometre
H70	picosecond
H71	percent per month A unit of proportion, equal to 0.01, in relation to a month.
H72	percent per hectobar A unit of proportion, equal to 0.01, in relation to 100-fold of the unit bar.
H73	percent per decakelvin A unit of proportion, equal to 0.01, in relation to 10-fold of the SI base unit Kelvin.
H74	watt per metre
H75	decapascal
H76	gram per millimetre

## Used Codes

---

H77	module width A unit of measure used to describe the breadth of electronic assemblies as an installation standard or mounting dimension.
H78	conventional centimetre of water
H79	Charrière A unit of distance used for measuring the diameter of small tubes such as urological instruments and catheters. Synonym: French, French gauge, Charrière gauge
H80	rack unit A unit of measure used to describe the height in rack units of equipment intended for mounting in a 19-inch rack or a 23-inch rack. One rack unit is 1.75 inches (44.45 mm) high.
H81	millimetre per minute
H82	big point A unit of length defining the number of big points (big point: Adobe software(US) defines the big point to be exactly 1/72 inch (0.013 888 9 inch or 0.352 777 8 millimeters))
H83	litre per kilogram
H84	gram millimetre
H85	reciprocal week
H87	piece A unit of count defining the number of pieces (piece: a single item, article or exemplar).
H88	megaohm kilometre
H89	percent per ohm A unit of proportion, equal to 0.01, in relation to the SI derived unit ohm.
H90	percent per degree A unit of proportion, equal to 0.01, in relation to an angle of one degree.
H91	percent per ten thousand A unit of proportion, equal to 0.01, in relation to multiples of ten thousand.
H92	percent per one hundred thousand A unit of proportion, equal to 0.01, in relation to multiples of one hundred thousand.
H93	percent per hundred A unit of proportion, equal to 0.01, in relation to multiples of one hundred.
H94	percent per thousand A unit of proportion, equal to 0.01, in relation to multiples of one thousand.
H95	percent per volt A unit of proportion, equal to 0.01, in relation to the SI derived unit volt.



**Used Codes**

H96	percent per bar A unit of proportion, equal to 0.01, in relation to an atmospheric pressure of one bar.
H98	percent per inch A unit of proportion, equal to 0.01, in relation to an inch.
H99	percent per metre A unit of proportion, equal to 0.01, in relation to a metre.
HA	hank A unit of length, typically for yarn.
HAD	Piece Day Unit for measuring the item amount and time as required by DIN 18451
HAR	hectare Synonym: square hectometre
HBA	hectobar
HBX	hundred boxes A unit of count defining the number of boxes in multiples of one hundred box units.
HC	hundred count A unit of count defining the number of units counted in multiples of 100.
HDW	hundred kilogram, dry weight A unit of mass defining the number of hundred kilograms of a product, disregarding the water content of the product.
HEA	head A unit of count defining the number of heads (head: a person or animal considered as one of a number).
HGM	hectogram
HH	hundred cubic foot A unit of volume equal to one hundred cubic foot.
HIU	hundred international unit A unit of count defining the number of international units in multiples of 100.
HJ	metric horse power
HKM	hundred kilogram, net mass A unit of mass defining the number of hundred kilograms of a product, after deductions.
HLT	hectolitre
HM	mile per hour (statute mile)
HMO	Piece Month Unit for measuring the item amount and time as required by DIN 18451

**Used Codes**

HMQ	million cubic metre A unit of volume equal to one million cubic metres.
HMT	hectometre
HN	conventional millimetre of mercury
HP	conventional millimetre of water
HPA	hectolitre of pure alcohol A unit of volume equal to one hundred litres of pure alcohol.
HTZ	hertz
HUR	hour
HWE	Piece Week Unit for measuring the item amount and time as required by DIN 18451
IA	inch pound (pound inch)
IE	person A unit of count defining the number of persons.
INH	inch
INK	square inch
INQ	cubic inch Synonym: inch cubed
ISD	international sugar degree A unit of measure defining the sugar content of a solution, expressed in degrees.
IU	inch per second
IV	inch per second squared
J10	percent per millimetre A unit of proportion, equal to 0.01, in relation to a millimetre.
J12	per mille per psi A unit of pressure equal to one thousandth of a psi (pound-force per square inch).
J13	degree API A unit of relative density as a measure of how heavy or light a petroleum liquid is compared to water (API: American Petroleum Institute).
J14	degree Baume (origin scale) A traditional unit of relative density for liquids. Named after Antoine Baumé.
J15	degree Baume (US heavy) A unit of relative density for liquids heavier than water.
J16	degree Baume (US light) A unit of relative density for liquids lighter than water.

## Used Codes

---

J17	degree Balling A unit of density as a measure of sugar content, especially of beer wort. Named after Karl Balling.
J18	degree Brix A unit of proportion used in measuring the dissolved sugar-to-water mass ratio of a liquid. Named after Adolf Brix.
J19	degree Fahrenheit hour square foot per British thermal unit (thermochemical)
J2	joule per kilogram
J20	degree Fahrenheit per kelvin
J21	degree Fahrenheit per bar
J22	degree Fahrenheit hour square foot per British thermal unit (international table)
J23	degree Fahrenheit per hour
J24	degree Fahrenheit per minute
J25	degree Fahrenheit per second
J26	reciprocal degree Fahrenheit
J27	degree Oechsle A unit of density as a measure of sugar content of must, the unfermented liqueur from which wine is made. Named after Ferdinand Oechsle.
J28	degree Rankine per hour
J29	degree Rankine per minute
J30	degree Rankine per second
J31	degree Twaddell A unit of density for liquids that are heavier than water. 1 degree Twaddle represents a difference in specific gravity of 0.005.
J32	micropoise
J33	microgram per kilogram
J34	microgram per cubic metre kelvin
J35	microgram per cubic metre bar
J36	microlitre per litre
J38	baud A unit of signal transmission speed equal to one signalling event per second.
J39	British thermal unit (mean)
J40	British thermal unit (international table) foot per hour square foot degree Fahrenheit
J41	British thermal unit (international table) inch per hour square foot degree Fahrenheit

**Used Codes**

J42	British thermal unit (international table) inch per second square foot degree Fahrenheit
J43	British thermal unit (international table) per pound degree Fahrenheit
J44	British thermal unit (international table) per minute
J45	British thermal unit (international table) per second
J46	British thermal unit (thermochemical) foot per hour square foot degree Fahrenheit
J47	British thermal unit (thermochemical) per hour
J48	British thermal unit (thermochemical) inch per hour square foot degree Fahrenheit
J49	British thermal unit (thermochemical) inch per second square foot degree Fahrenheit
J50	British thermal unit (thermochemical) per pound degree Fahrenheit
J51	British thermal unit (thermochemical) per minute
J52	British thermal unit (thermochemical) per second
J53	coulomb square metre per kilogram
J54	megabaud A unit of signal transmission speed equal to 10 to the power of 6 (1000000) signaling events per second.
J55	watt second
J56	bar per bar
J57	barrel (UK petroleum)
J58	barrel (UK petroleum) per minute
J59	barrel (UK petroleum) per day
J60	barrel (UK petroleum) per hour
J61	barrel (UK petroleum) per second
J62	barrel (US petroleum) per hour
J63	barrel (US petroleum) per second
J64	bushel (UK) per day
J65	bushel (UK) per hour
J66	bushel (UK) per minute
J67	bushel (UK) per second
J68	bushel (US dry) per day
J69	bushel (US dry) per hour
J70	bushel (US dry) per minute

**Used Codes**

J71	bushel (US dry) per second
J72	centinewton metre
J73	centipoise per kelvin
J74	centipoise per bar
J75	calorie (mean)
J76	calorie (international table) per gram degree Celsius
J78	calorie (thermochemical) per centimetre second degree Celsius
J79	calorie (thermochemical) per gram degree Celsius
J81	calorie (thermochemical) per minute
J82	calorie (thermochemical) per second
J83	clo
J84	centimetre per second kelvin
J85	centimetre per second bar
J87	cubic centimetre per cubic metre
J89	centimetre of mercury
J90	cubic decimetre per day
J91	cubic decimetre per cubic metre
J92	cubic decimetre per minute
J93	cubic decimetre per second
J94	dyne centimetre
J95	ounce (UK fluid) per day
J96	ounce (UK fluid) per hour
J97	ounce (UK fluid) per minute
J98	ounce (UK fluid) per second
J99	ounce (US fluid) per day
JE	joule per kelvin
JK	megajoule per kilogram
JM	megajoule per cubic metre
JNT	pipeline joint A count of the number of pipeline joints.
JOU	joule
JPS	hundred metre A unit of count defining the number of 100 metre lengths.

**Used Codes**

JWL	number of jewels A unit of count defining the number of jewels (jewel: precious stone).
K1	kilowatt demand A unit of measure defining the power load measured at predetermined intervals.
K10	ounce (US fluid) per hour
K11	ounce (US fluid) per minute
K12	ounce (US fluid) per second
K13	foot per degree Fahrenheit
K14	foot per hour
K15	foot pound-force per hour
K16	foot pound-force per minute
K17	foot per psi
K18	foot per second degree Fahrenheit
K19	foot per second psi
K2	kilovolt ampere reactive demand A unit of measure defining the reactive power demand equal to one kilovolt ampere of reactive power.
K20	reciprocal cubic foot
K21	cubic foot per degree Fahrenheit
K22	cubic foot per day
K23	cubic foot per psi
K24	foot of water
K25	foot of mercury
K26	gallon (UK) per day
K27	gallon (UK) per hour
K28	gallon (UK) per second
K3	kilovolt ampere reactive hour A unit of measure defining the accumulated reactive energy equal to one kilovolt ampere of reactive power per hour.
K30	gallon (US liquid) per second
K31	gram-force per square centimetre
K32	gill (UK) per day
K33	gill (UK) per hour
K34	gill (UK) per minute

**Used Codes**

K35	gill (UK) per second
K36	gill (US) per day
K37	gill (US) per hour
K38	gill (US) per minute
K39	gill (US) per second
K40	standard acceleration of free fall
K41	grain per gallon (US)
K42	horsepower (boiler)
K43	horsepower (electric)
K45	inch per degree Fahrenheit
K46	inch per psi
K47	inch per second degree Fahrenheit
K48	inch per second psi
K49	reciprocal cubic inch
K5	kilovolt ampere (reactive) Use kilovar (common code KVR)
K50	kilobaud A unit of signal transmission speed equal to 10 to the power of 3 (1000) signaling events per second.
K51	kilocalorie (mean)
K52	kilocalorie (international table) per hour metre degree Celsius
K53	kilocalorie (thermochemical)
K54	kilocalorie (thermochemical) per minute
K55	kilocalorie (thermochemical) per second
K58	kilomole per hour
K59	kilomole per cubic metre kelvin
K6	kilolitre
K60	kilomole per cubic metre bar
K61	kilomole per minute
K62	litre per litre
K63	reciprocal litre
K64	pound (avoirdupois) per degree Fahrenheit
K65	pound (avoirdupois) square foot
K66	pound (avoirdupois) per day

**Used Codes**

K67	pound per foot hour
K68	pound per foot second
K69	pound (avoirdupois) per cubic foot degree Fahrenheit
K70	pound (avoirdupois) per cubic foot psi
K71	pound (avoirdupois) per gallon (UK)
K73	pound (avoirdupois) per hour degree Fahrenheit
K74	pound (avoirdupois) per hour psi
K75	pound (avoirdupois) per cubic inch degree Fahrenheit
K76	pound (avoirdupois) per cubic inch psi
K77	pound (avoirdupois) per psi
K78	pound (avoirdupois) per minute
K79	pound (avoirdupois) per minute degree Fahrenheit
K80	pound (avoirdupois) per minute psi
K81	pound (avoirdupois) per second
K82	pound (avoirdupois) per second degree Fahrenheit
K83	pound (avoirdupois) per second psi
K84	pound per cubic yard
K85	pound-force per square foot
K86	pound-force per square inch degree Fahrenheit
K87	psi cubic inch per second
K88	psi litre per second
K89	psi cubic metre per second
K90	psi cubic yard per second
K91	pound-force second per square foot
K92	pound-force second per square inch
K93	reciprocal psi
K94	quart (UK liquid) per day
K95	quart (UK liquid) per hour
K96	quart (UK liquid) per minute
K97	quart (UK liquid) per second
K98	quart (US liquid) per day
K99	quart (US liquid) per hour



## Used Codes

---

KA	cake A unit of count defining the number of cakes (cake: object shaped into a flat, compact mass).
KAT	katal A unit of catalytic activity defining the catalytic activity of enzymes and other catalysts.
KB	kilocharacter A unit of information equal to 10 to the power of 3 (1000) characters.
KBA	kilobar
KCC	kilogram of choline chloride A unit of mass equal to one thousand grams of choline chloride.
KDW	kilogram drained net weight A unit of mass defining the net number of kilograms of a product, disregarding the liquid content of the product.
KEL	kelvin Refer ISO 80000-5 (Quantities and units — Part 5: Thermodynamics)
KGM	kilogram A unit of mass equal to one thousand grams.
KGS	kilogram per second
KHY	kilogram of hydrogen peroxide A unit of mass equal to one thousand grams of hydrogen peroxide.
KHZ	kilohertz
KI	kilogram per millimetre width
KIC	kilogram, including container A unit of mass defining the number of kilograms of a product, including its container.
KIP	kilogram, including inner packaging A unit of mass defining the number of kilograms of a product, including its inner packaging materials.
KJ	kilosegment A unit of information equal to 10 to the power of 3 (1000) segments.
KJO	kilojoule
KL	kilogram per metre
KLK	lactic dry material percentage A unit of proportion defining the percentage of dry lactic material in a product.
KLX	kilolux A unit of illuminance equal to one thousand lux.

## Used Codes

KMA	kilogram of methylamine A unit of mass equal to one thousand grams of methylamine.
KMH	kilometre per hour
KMK	square kilometre
KMQ	kilogram per cubic metre A unit of weight expressed in kilograms of a substance that fills a volume of one cubic metre.
KMT	kilometre
KNI	kilogram of nitrogen A unit of mass equal to one thousand grams of nitrogen.
KNM	kilonewton per square metre Pressure expressed in kN/m <sup>2</sup> .
KNS	kilogram named substance A unit of mass equal to one kilogram of a named substance.
KNT	knot
KO	milliequivalence caustic potash per gram of product A unit of count defining the number of milligrams of potassium hydroxide per gram of product as a measure of the concentration of potassium hydroxide in the product.
KPA	kilopascal
KPH	kilogram of potassium hydroxide (caustic potash) A unit of mass equal to one thousand grams of potassium hydroxide (caustic potash).
KPO	kilogram of potassium oxide A unit of mass equal to one thousand grams of potassium oxide.
KPP	kilogram of phosphorus pentoxide (phosphoric anhydride) A unit of mass equal to one thousand grams of phosphorus pentoxide phosphoric anhydride.
KR	kiloroentgen
KSD	kilogram of substance 90 % dry A unit of mass equal to one thousand grams of a named substance that is 90% dry.
KSH	kilogram of sodium hydroxide (caustic soda) A unit of mass equal to one thousand grams of sodium hydroxide (caustic soda).
KT	kit A unit of count defining the number of kits (kit: tub, barrel or pail).
KTN	kilotonne

**Used Codes**

KUR	kilogram of uranium A unit of mass equal to one thousand grams of uranium.
KVA	kilovolt - ampere
KVR	kilovar
KVT	kilovolt
KW	kilogram per millimetre
KWH	kilowatt hour
KWN	Kilowatt hour per normalized cubic metre Kilowatt hour per normalized cubic metre (temperature 0°C and pressure 1013.25 millibars ).
KWO	kilogram of tungsten trioxide A unit of mass equal to one thousand grams of tungsten trioxide.
KWS	Kilowatt hour per standard cubic metre Kilowatt hour per standard cubic metre (temperature 15°C and pressure 1013.25 millibars).
KWT	kilowatt
KWY	kilowatt year killowatt year
KX	millilitre per kilogram
L10	quart (US liquid) per minute
L11	quart (US liquid) per second
L12	metre per second kelvin
L13	metre per second bar
L14	square metre hour degree Celsius per kilocalorie (international table)
L15	millipascal second per kelvin
L16	millipascal second per bar
L17	milligram per cubic metre kelvin
L18	milligram per cubic metre bar
L19	millilitre per litre
L2	litre per minute
L20	reciprocal cubic millimetre
L21	cubic millimetre per cubic metre
L23	mole per hour
L24	mole per kilogram kelvin
L25	mole per kilogram bar

**Used Codes**

L26	mole per litre kelvin
L27	mole per litre bar
L28	mole per cubic metre kelvin
L29	mole per cubic metre bar
L30	mole per minute
L31	milliroentgen aequivalent men
L32	nanogram per kilogram
L33	ounce (avoirdupois) per day
L34	ounce (avoirdupois) per hour
L35	ounce (avoirdupois) per minute
L36	ounce (avoirdupois) per second
L37	ounce (avoirdupois) per gallon (UK)
L38	ounce (avoirdupois) per gallon (US)
L39	ounce (avoirdupois) per cubic inch
L40	ounce (avoirdupois)-force
L41	ounce (avoirdupois)-force inch
L42	picosiemens per metre
L43	peck (UK)
L44	peck (UK) per day
L45	peck (UK) per hour
L46	peck (UK) per minute
L47	peck (UK) per second
L48	peck (US dry) per day
L49	peck (US dry) per hour
L50	peck (US dry) per minute
L51	peck (US dry) per second
L52	psi per psi
L53	pint (UK) per day
L54	pint (UK) per hour
L55	pint (UK) per minute
L56	pint (UK) per second
L57	pint (US liquid) per day
L58	pint (US liquid) per hour

**Used Codes**

L59	pint (US liquid) per minute
L60	pint (US liquid) per second
L63	slug per day
L64	slug per foot second
L65	slug per cubic foot
L66	slug per hour
L67	slug per minute
L68	slug per second
L69	tonne per kelvin
L70	tonne per bar
L71	tonne per day
L72	tonne per day kelvin
L73	tonne per day bar
L74	tonne per hour kelvin
L75	tonne per hour bar
L76	tonne per cubic metre kelvin
L77	tonne per cubic metre bar
L78	tonne per minute
L79	tonne per minute kelvin
L80	tonne per minute bar
L81	tonne per second
L82	tonne per second kelvin
L83	tonne per second bar
L84	ton (UK shipping)
L85	ton long per day
L86	ton (US shipping)
L87	ton short per degree Fahrenheit
L88	ton short per day
L89	ton short per hour degree Fahrenheit
L90	ton short per hour psi
L91	ton short per psi
L92	ton (UK long) per cubic yard
L93	ton (US short) per cubic yard

**Used Codes**

L94	ton-force (US short)
L95	common year
L96	sidereal year
L98	yard per degree Fahrenheit
L99	yard per psi
LA	pound per cubic inch
LAC	lactose excess percentage A unit of proportion defining the percentage of lactose in a product that exceeds a defined percentage level.
LBR	pound
LBT	troy pound (US)
LD	litre per day
LEF	leaf A unit of count defining the number of leaves.
LF	linear foot A unit of count defining the number of feet (12-inch) in length of a uniform width object.
LH	labour hour A unit of time defining the number of labour hours.
LK	link A unit of distance equal to 0.01 chain.
LM	linear metre A unit of count defining the number of metres in length of a uniform width object.
LN	length A unit of distance defining the linear extent of an item measured from end to end.
LO	lot [unit of procurement] A unit of count defining the number of lots (lot: a collection of associated items).
LP	liquid pound A unit of mass defining the number of pounds of a liquid substance.
LPA	litre of pure alcohol A unit of volume equal to one litre of pure alcohol.
LR	layer A unit of count defining the number of layers.

**Used Codes**

LS	lump sum A unit of count defining the number of whole or a complete monetary amounts.
LTN	ton (UK) or long ton (US) Synonym: gross ton (2240 lb)
LTR	litre
LUB	metric ton, lubricating oil A unit of mass defining the number of metric tons of lubricating oil.
LUM	lumen
LUX	lux
LY	linear yard A unit of count defining the number of 36-inch units in length of a uniform width object.
M1	milligram per litre
M10	reciprocal cubic yard
M11	cubic yard per degree Fahrenheit
M12	cubic yard per day
M13	cubic yard per hour
M14	cubic yard per psi
M15	cubic yard per minute
M16	cubic yard per second
M17	kilohertz metre
M18	gigahertz metre
M19	Beaufort An empirical measure for describing wind speed based mainly on observed sea conditions. The Beaufort scale indicates the wind speed by numbers that typically range from 0 for calm, to 12 for hurricane.
M20	reciprocal megakelvin or megakelvin to the power minus one
M21	reciprocal kilovolt - ampere reciprocal hour
M22	millilitre per square centimetre minute
M23	newton per centimetre
M24	ohm kilometre
M25	percent per degree Celsius A unit of proportion, equal to 0.01, in relation to a temperature of one degree.
M26	gigaohm per metre
M27	megahertz metre

## Used Codes

M29	kilogram per kilogram
M30	reciprocal volt - ampere reciprocal second
M31	kilogram per kilometre
M32	pascal second per litre
M33	millimole per litre
M34	newton metre per square metre
M35	millivolt - ampere
M36	30-day month A unit of count defining the number of months expressed in multiples of 30 days, one day equals 24 hours.
M37	actual/360 A unit of count defining the number of years expressed in multiples of 360 days, one day equals 24 hours.
M38	kilometre per second squared 1000-fold of the SI base unit metre divided by the power of the SI base unit second by exponent 2.
M39	centimetre per second squared 0,01-fold of the SI base unit metre divided by the power of the SI base unit second by exponent 2.
M4	monetary value A unit of measure expressed as a monetary amount.
M40	yard per second squared Unit of the length according to the Anglo-American and Imperial system of units divided by the power of the SI base unit second by exponent 2.
M41	millimetre per second squared 0,001-fold of the SI base unit metre divided by the power of the SI base unit second by exponent 2.
M42	mile (statute mile) per second squared Unit of the length according to the Imperial system of units divided by the power of the SI base unit second by exponent 2.
M43	mil Unit to indicate an angle at military zone, equal to the 6400th part of the full circle of the 360° or 2·p·rad.
M44	revolution Unit to identify an angle of the full circle of 360° or 2·p·rad (Refer ISO/TC12 SI Guide).
M45	degree [unit of angle] per second squared 360 part of a full circle divided by the power of the SI base unit second and the exponent 2.



**Used Codes**

M46	revolution per minute Unit of the angular velocity.
M47	circular mil Unit of an area, of which the size is given by a diameter of length of 1 mm (0,001 in) based on the formula: $\text{area} = \pi \cdot (\text{diameter}/2)^2$ .
M48	square mile (based on U.S. survey foot) Unit of the area, which is mainly common in the agriculture and forestry.
M49	chain (based on U.S. survey foot) Unit of the length according the Anglo-American system of units.
M5	microcurie
M50	furlong Unit commonly used in Great Britain at rural distances: 1 furlong = 40 rods = 10 chains (UK) = 1/8 mile = 1/10 furlong = 220 yards = 660 foot.
M51	foot (U.S. survey) Unit commonly used in the United States for ordnance survey.
M52	mile (based on U.S. survey foot) Unit commonly used in the United States for ordnance survey.
M53	metre per pascal SI base unit metre divided by the derived SI unit pascal.
M55	metre per radiant Unit of the translation factor for implementation from rotation to linear movement.
M56	shake Unit for a very short period.
M57	mile per minute Unit of velocity from the Imperial system of units.
M58	mile per second Unit of the velocity from the Imperial system of units.
M59	metre per second pascal SI base unit meter divided by the product of SI base unit second and the derived SI unit pascal.
M60	metre per hour SI base unit metre divided by the unit hour.
M61	inch per year Unit of the length according to the Anglo-American and Imperial system of units divided by the unit common year with 365 days.
M62	kilometre per second 1000-fold of the SI base unit metre divided by the SI base unit second.

## Used Codes

---

M63	inch per minute Unit inch according to the Anglo-American and Imperial system of units divided by the unit minute.
M64	yard per second Unit yard according to the Anglo-American and Imperial system of units divided by the SI base unit second.
M65	yard per minute Unit yard according to the Anglo-American and Imperial system of units divided by the unit minute.
M66	yard per hour Unit yard according to the Anglo-American and Imperial system of units divided by the unit hour.
M67	acre-foot (based on U.S. survey foot) Unit of the volume, which is used in the United States to measure/gauge the capacity of reservoirs.
M68	cord (128 ft <sup>3</sup> ) Traditional unit of the volume of stacked firewood which has been measured with a cord.
M69	cubic mile (UK statute) Unit of volume according to the Imperial system of units.
M7	micro-inch
M70	ton, register Traditional unit of the cargo capacity.
M71	cubic metre per pascal Power of the SI base unit meter by exponent 3 divided by the derived SI base unit pascal.
M72	bel Logarithmic relationship to base 10.
M73	kilogram per cubic metre pascal SI base unit kilogram divided by the product of the power of the SI base unit metre with exponent 3 and the derived SI unit pascal.
M74	kilogram per pascal SI base unit kilogram divided by the derived SI unit pascal.
M75	kilopound-force 1000-fold of the unit of the force pound-force (lbf) according to the Anglo-American system of units with the relationship.
M76	poundal Non SI-conforming unit of the power, which corresponds to a mass of a pound multiplied with the acceleration of a foot per square second.

## Used Codes

---

M77	kilogram metre per second squared Product of the SI base unit kilogram and the SI base unit metre divided by the power of the SI base unit second by exponent 2.
M78	pond 0,001-fold of the unit of the weight, defined as a mass of 1 kg which finds out about a weight strength from 1 kp by the gravitational force at sea level which corresponds to a strength of 9,806 65 newton.
M79	square foot per hour Power of the unit foot according to the Anglo-American and Imperial system of units by exponent 2 divided by the unit of time hour.
M80	stokes per pascal CGS (Centimetre-Gram-Second system) unit stokes divided by the derived SI unit pascal.
M81	square centimetre per second 0,000 1-fold of the power of the SI base unit metre by exponent 2 divided by the SI base unit second.
M82	square metre per second pascal Power of the SI base unit metre with the exponent 2 divided by the SI base unit second and the derived SI unit pascal.
M83	denier Traditional unit for the indication of the linear mass of textile fibers and yarns.
M84	pound per yard Unit for linear mass according to avoirdupois system of units.
M85	ton, assay Non SI-conforming unit of the mass used in the mineralogy to determine the concentration of precious metals in ore according to the mass of the precious metal in milligrams in a sample of the mass of an assay sound (number of troy ounces in a short ton (1 000 lb)).
M86	pfund Outdated unit of the mass used in Germany.
M87	kilogram per second pascal SI base unit kilogram divided by the product of the SI base unit second and the derived SI unit pascal.
M88	tonne per month Unit tonne divided by the unit month.
M89	tonne per year Unit tonne divided by the unit year with 365 days.
M9	million Btu per 1000 cubic foot
M90	kilopound per hour 1000-fold of the unit of the mass avoirdupois pound according to the avoirdupois unit system divided by the unit hour.

## Used Codes

---

M91	pound per pound Proportion of the mass consisting of the avoirdupois pound according to the avoirdupois unit system divided by the avoirdupois pound according to the avoirdupois unit system.
M92	pound-force foot Product of the unit pound-force according to the Anglo-American system of units and the unit foot according to the Anglo-American and the Imperial system of units.
M93	newton metre per radian Product of the derived SI unit newton and the SI base unit metre divided by the unit radian.
M94	kilogram metre Unit of imbalance as a product of the SI base unit kilogram and the SI base unit metre.
M95	poundal foot Product of the non SI-conforming unit of the force poundal and the unit foot according to the Anglo-American and Imperial system of units .
M96	poundal inch Product of the non SI-conforming unit of the force poundal and the unit inch according to the Anglo-American and Imperial system of units .
M97	dyne metre CGS (Centimetre-Gram-Second system) unit of the rotational moment.
M98	kilogram centimetre per second Product of the SI base unit kilogram and the 0,01-fold of the SI base unit metre divided by the SI base unit second.
M99	gram centimetre per second Product of the 0,001-fold of the SI base unit kilogram and the 0,01-fold of the SI base unit metre divided by the SI base unit second.
MAH	megavolt ampere reactive hour A unit of electrical reactive power defining the total amount of reactive power across a power system.
MAL	megalitre
MAM	megametre
MAR	megavar A unit of electrical reactive power represented by a current of one thousand amperes flowing due a potential difference of one thousand volts where the sine of the phase angle between them is 1.
MAW	megawatt A unit of power defining the rate of energy transferred or consumed when a current of 1000 amperes flows due to a potential of 1000 volts at unity power factor.

**Used Codes**

MBE	thousand standard brick equivalent A unit of count defining the number of one thousand brick equivalent units.
MBF	thousand board foot A unit of volume equal to one thousand board foot.
MBR	millibar
MC	microgram
MCU	millicurie
MD	air dry metric ton A unit of count defining the number of metric tons of a product, disregarding the water content of the product.
MGM	milligram
MHZ	megahertz
MIK	square mile (statute mile)
MIL	thousand
MIN	minute [unit of time]
MIO	million
MIU	million international unit A unit of count defining the number of international units in multiples of 10 to the power of 6.
MKD	Square Metre Day Unit for measuring physical dimensions and time as required by DIN 18451
MKM	Square Metre Month Unit for measuring physical dimensions and time as required by DIN 18451
MKW	Square Metre Week Unit for measuring physical dimensions and time as required by DIN 18451
MLD	milliard Synonym: billion (US)
MLT	millilitre
MMK	square millimetre
MMQ	cubic millimetre
MMT	millimetre
MND	kilogram, dry weight A unit of mass defining the number of kilograms of a product, disregarding the water content of the product.
MNJ	Mega Joule per Normalised cubic Metre Energy in Mega Joules per normalised cubic metre for gas (temperature 0°C and pressure 101325 millibars)

**Used Codes**

MON	month Unit of time equal to 1/12 of a year of 365,25 days.
MPA	megapascal
MQD	Cubic Metre Day Unit for measuring physical dimensions and time as required by DIN 18451
MQH	cubic metre per hour
MQM	Cubic Metre Month Unit for measuring physical dimensions and time as required by DIN 18451
MQS	cubic metre per second
MQW	Cubic Metre Week Unit for measuring physical dimensions and time as required by DIN 18451
MRD	Metre Day Unit for measuring physical dimensions and time as required by DIN 18451
MRM	Metre Month Unit for measuring physical dimensions and time as required by DIN 18451
MRW	Metre Week Unit for measuring physical dimensions and time, as required by DIN 18451
MSK	metre per second squared
MTK	square metre
MTQ	cubic metre Synonym: metre cubed
MTR	metre
MTS	metre per second
MTZ	milihertz A unit of frequency equal to 0.001 cycle per second
MVA	megavolt - ampere
MWH	megawatt hour (1000 kW.h) A unit of power defining the total amount of bulk energy transferred or consumed.
N1	pen calorie A unit of count defining the number of calories prescribed daily for parenteral/enteral therapy.
N10	pound foot per second Product of the avoirdupois pound according to the avoirdupois unit system and the unit foot according to the Anglo-American and Imperial system of units divided by the SI base unit second.

## Used Codes

N11	pound inch per second Product of the avoirdupois pound according to the avoirdupois unit system and the unit inch according to the Anglo-American and Imperial system of units divided by the SI base unit second.
N12	Pferdestaerke Obsolete unit of the power relating to DIN 1301-3:1979: 1 PS = 735,498 75 W.
N13	centimetre of mercury (0 °C) Non SI-conforming unit of pressure, at which a value of 1 cmHg meets the static pressure, which is generated by a mercury at a temperature of 0 °C with a height of 1 centimetre .
N14	centimetre of water (4 °C) Non SI-conforming unit of pressure, at which a value of 1 cmH <sub>2</sub> O meets the static pressure, which is generated by a head of water at a temperature of 4 °C with a height of 1 centimetre .
N15	foot of water (39.2 °F) Non SI-conforming unit of pressure according to the Anglo-American and Imperial system for units, whereas the value of 1 ftH <sub>2</sub> O is equivalent to the static pressure, which is generated by a head of water at a temperature 39,2°F with a height of 1 foot .
N16	inch of mercury (32 °F) Non SI-conforming unit of pressure according to the Anglo-American and Imperial system for units, whereas the value of 1 inHg meets the static pressure, which is generated by a mercury at a temperature of 32°F with a height of 1 inch.
N17	inch of mercury (60 °F) Non SI-conforming unit of pressure according to the Anglo-American and Imperial system for units, whereas the value of 1 inHg meets the static pressure, which is generated by a mercury at a temperature of 60°F with a height of 1 inch.
N18	inch of water (39.2 °F) Non SI-conforming unit of pressure according to the Anglo-American and Imperial system for units, whereas the value of 1 inH <sub>2</sub> O meets the static pressure, which is generated by a head of water at a temperature of 39,2°F with a height of 1 inch .
N19	inch of water (60 °F) Non SI-conforming unit of pressure according to the Anglo-American and Imperial system for units, whereas the value of 1 inH <sub>2</sub> O meets the static pressure, which is generated by a head of water at a temperature of 60°F with a height of 1 inch .
N20	kip per square inch Non SI-conforming unit of the pressure according to the Anglo-American system of units as the 1000-fold of the unit of the force pound-force divided by the power of the unit inch by exponent 2.

## Used Codes

N21	poundal per square foot Non SI-conforming unit of pressure by the Imperial system of units according to NIST: $1 \text{ pdl/ft}^2 = 1,488 \text{ 164 Pa}$ .
N22	ounce (avoirdupois) per square inch Unit of the surface specific mass (avoirdupois ounce according to the avoirdupois system of units according to the surface square inch according to the Anglo-American and Imperial system of units).
N23	conventional metre of water Not SI-conforming unit of pressure, whereas a value of 1 mH <sub>2</sub> O is equivalent to the static pressure, which is produced by one metre high water column .
N24	gram per square millimetre 0,001-fold of the SI base unit kilogram divided by the 0.000 001-fold of the power of the SI base unit meter by exponent 2.
N25	pound per square yard Unit for areal-related mass as a unit pound according to the avoirdupois unit system divided by the power of the unit yard according to the Anglo-American and Imperial system of units with exponent 2.
N26	poundal per square inch Non SI-conforming unit of the pressure according to the Imperial system of units (poundal by square inch).
N27	foot to the fourth power Power of the unit foot according to the Anglo-American and Imperial system of units by exponent 4 according to NIST: $1 \text{ ft}^4 = 8,630 \text{ 975 m}^4$ .
N28	cubic decimetre per kilogram 0,001 fold of the power of the SI base unit meter by exponent 3 divided by the SI based unit kilogram.
N29	cubic foot per pound Power of the unit foot according to the Anglo-American and Imperial system of units by exponent 3 divided by the unit avoirdupois pound according to the avoirdupois unit system.
N3	print point
N30	cubic inch per pound Power of the unit inch according to the Anglo-American and Imperial system of units by exponent 3 divided by the avoirdupois pound according to the avoirdupois unit system .
N31	kilonewton per metre 1000-fold of the derived SI unit newton divided by the SI base unit metre.
N32	poundal per inch Non SI-conforming unit of the surface tension according to the Imperial unit system as quotient poundal by inch.
N33	pound-force per yard Unit of force per unit length based on the Anglo-American system of units.



## Used Codes

N34	poundal second per square foot Non SI-conforming unit of viscosity.
N35	poise per pascal CGS (Centimetre-Gram-Second system) unit poise divided by the derived SI unit pascal.
N36	newton second per square metre Unit of the dynamic viscosity as a product of unit of the pressure (newton by square metre) multiplied with the SI base unit second.
N37	kilogram per metre second Unit of the dynamic viscosity as a quotient SI base unit kilogram divided by the SI base unit metre and by the SI base unit second.
N38	kilogram per metre minute Unit of the dynamic viscosity as a quotient SI base unit kilogram divided by the SI base unit metre and by the unit minute.
N39	kilogram per metre day Unit of the dynamic viscosity as a quotient SI base unit kilogram divided by the SI base unit metre and by the unit day.
N40	kilogram per metre hour Unit of the dynamic viscosity as a quotient SI base unit kilogram divided by the SI base unit metre and by the unit hour.
N41	gram per centimetre second Unit of the dynamic viscosity as a quotient of the 0,001-fold of the SI base unit kilogram divided by the 0,01-fold of the SI base unit metre and SI base unit second.
N42	poundal second per square inch Non SI-conforming unit of dynamic viscosity according to the Imperial system of units as product unit of the pressure (poundal by square inch) multiplied by the SI base unit second.
N43	pound per foot minute Unit of the dynamic viscosity according to the Anglo-American unit system.
N44	pound per foot day Unit of the dynamic viscosity according to the Anglo-American unit system.
N45	cubic metre per second pascal Power of the SI base unit meter by exponent 3 divided by the product of the SI base unit second and the derived SI base unit pascal.
N46	foot poundal Unit of the work (force-path).
N47	inch poundal Unit of work (force multiplied by path) according to the Imperial system of units as a product unit inch multiplied by poundal.

## Used Codes

---

N48	watt per square centimetre Derived SI unit watt divided by the power of the 0,01-fold the SI base unit metre by exponent 2.
N49	watt per square inch Derived SI unit watt divided by the power of the unit inch according to the Anglo-American and Imperial system of units by exponent 2.
N50	British thermal unit (international table) per square foot hour Unit of the surface heat flux according to the Imperial system of units.
N51	British thermal unit (thermochemical) per square foot hour Unit of the surface heat flux according to the Imperial system of units.
N52	British thermal unit (thermochemical) per square foot minute Unit of the surface heat flux according to the Imperial system of units.
N53	British thermal unit (international table) per square foot second Unit of the surface heat flux according to the Imperial system of units.
N54	British thermal unit (thermochemical) per square foot second Unit of the surface heat flux according to the Imperial system of units.
N55	British thermal unit (international table) per square inch second Unit of the surface heat flux according to the Imperial system of units.
N56	calorie (thermochemical) per square centimetre minute Unit of the surface heat flux according to the Imperial system of units.
N57	calorie (thermochemical) per square centimetre second Unit of the surface heat flux according to the Imperial system of units.
N58	British thermal unit (international table) per cubic foot Unit of the energy density according to the Imperial system of units.
N59	British thermal unit (thermochemical) per cubic foot Unit of the energy density according to the Imperial system of units.
N60	British thermal unit (international table) per degree Fahrenheit Unit of the heat capacity according to the Imperial system of units.
N61	British thermal unit (thermochemical) per degree Fahrenheit Unit of the heat capacity according to the Imperial system of units.
N62	British thermal unit (international table) per degree Rankine Unit of the heat capacity according to the Imperial system of units.
N63	British thermal unit (thermochemical) per degree Rankine Unit of the heat capacity according to the Imperial system of units.

## Used Codes

---

N64	British thermal unit (thermochemical) per pound degree Rankine Unit of the heat capacity (British thermal unit according to the international table according to the Rankine degree) according to the Imperial system of units divided by the unit avoirdupois pound according to the avoirdupois system of units.
N65	kilocalorie (international table) per gram kelvin Unit of the mass-related heat capacity as quotient 1000-fold of the calorie (international table) divided by the product of the 0,001-fold of the SI base units kilogram and kelvin.
N66	British thermal unit (39 °F) Unit of heat energy according to the Imperial system of units in a reference temperature of 39 °F.
N67	British thermal unit (59 °F) Unit of heat energy according to the Imperial system of units in a reference temperature of 59 °F.
N68	British thermal unit (60 °F) Unit of head energy according to the Imperial system of units at a reference temperature of 60 °F.
N69	calorie (20 °C) Unit for quantity of heat, which is to be required for 1 g air free water at a constant pressure from 101,325 kPa, to warm up the pressure of standard atmosphere at sea level, from 19,5 °C on 20,5 °C.
N70	quad (1015 BtuIT) Unit of heat energy according to the imperial system of units.
N71	therm (EC) Unit of heat energy in commercial use, within the EU defined: 1 thm (EC) = 100 000 BtuIT.
N72	therm (U.S.) Unit of heat energy in commercial use.
N73	British thermal unit (thermochemical) per pound Unit of the heat energy according to the Imperial system of units divided the unit avoirdupois pound according to the avoirdupois system of units.
N74	British thermal unit (international table) per hour square foot degree Fahrenheit Unit of the heat transition coefficient according to the Imperial system of units.
N75	British thermal unit (thermochemical) per hour square foot degree Fahrenheit Unit of the heat transition coefficient according to the imperial system of units.
N76	British thermal unit (international table) per second square foot degree Fahrenheit Unit of the heat transition coefficient according to the imperial system of units.

## Used Codes

---

N77	British thermal unit (thermochemical) per second square foot degree Fahrenheit Unit of the heat transition coefficient according to the imperial system of units.
N78	kilowatt per square metre kelvin 1000-fold of the derived SI unit watt divided by the product of the power of the SI base unit metre by exponent 2 and the SI base unit kelvin.
N79	kelvin per pascal SI base unit kelvin divided by the derived SI unit pascal.
N80	watt per metre degree Celsius Derived SI unit watt divided by the product of the SI base unit metre and the unit for temperature degree Celsius.
N81	kilowatt per metre kelvin 1000-fold of the derived SI unit watt divided by the product of the SI base unit metre and the SI base unit kelvin.
N82	kilowatt per metre degree Celsius 1000-fold of the derived SI unit watt divided by the product of the SI base unit metre and the unit for temperature degree Celsius.
N83	metre per degree Celsius metre SI base unit metre divided by the product of the unit degree Celsius and the SI base unit metre.
N84	degree Fahrenheit hour per British thermal unit (international table) Non SI-conforming unit of the thermal resistance according to the Imperial system of units.
N85	degree Fahrenheit hour per British thermal unit (thermochemical) Non SI-conforming unit of the thermal resistance according to the Imperial system of units.
N86	degree Fahrenheit second per British thermal unit (international table) Non SI-conforming unit of the thermal resistance according to the Imperial system of units.
N87	degree Fahrenheit second per British thermal unit (thermochemical) Non SI-conforming unit of the thermal resistance according to the Imperial system of units.
N88	degree Fahrenheit hour square foot per British thermal unit (international table) inch Unit of specific thermal resistance according to the Imperial system of units.
N89	degree Fahrenheit hour square foot per British thermal unit (thermochemical) inch Unit of specific thermal resistance according to the Imperial system of units.
N90	kilofarad 1000-fold of the derived SI unit farad.

## Used Codes

---

N91	reciprocal joule Reciprocal of the derived SI unit joule.
N92	pico Siemens 0,000 000 000 001-fold of the derived SI unit siemens.
N93	ampere per pascal SI base unit ampere divided by the derived SI unit pascal.
N94	franklin CGS (Centimetre-Gram-Second system) unit of the electrical charge, where the charge amounts to exactly 1 Fr where the force of 1 dyn on an equal load is performed at a distance of 1 cm.
N95	ampere minute A unit of electric charge defining the amount of charge accumulated by a steady flow of one ampere for one minute..
N96	biot CGS (Centimetre-Gram-Second system) unit of the electric power which is defined by a force of 2 dyn per cm between two parallel conductors of infinite length with negligible cross-section in the distance of 1 cm.
N97	gilbert CGS (Centimetre-Gram-Second system) unit of the magnetomotive force, which is defined by the work to increase the magnetic potential of a positive common pole with 1 erg.
N98	volt per pascal Derived SI unit volt divided by the derived SI unit pascal.
N99	picovolt 0,000 000 000 001-fold of the derived SI unit volt.
NA	milligram per kilogram
NAR	number of articles A unit of count defining the number of articles (article: item).
NCL	number of cells A unit of count defining the number of cells (cell: an enclosed or circumscribed space, cavity, or volume).
NEW	newton
NF	message A unit of count defining the number of messages.
NIL	nil A unit of count defining the number of instances of nothing.
NIU	number of international units A unit of count defining the number of international units.

## Used Codes

---

NL	load A unit of volume defining the number of loads (load: a quantity of items carried or processed at one time).
NM3	Normalised cubic metre Normalised cubic metre (temperature 0°C and pressure 1013.25 millibars )
NMI	nautical mile
NMP	number of packs A unit of count defining the number of packs (pack: a collection of objects packaged together).
NPR	number of pairs A unit of count defining the number of pairs (pair: item described by two's).
NPT	number of parts A unit of count defining the number of parts (part: component of a larger entity).
NQ	mho
NR	micromho
NT	net ton A unit of mass equal to 2000 pounds, see ton (US). Refer International Convention on tonnage measurement of Ships.
NTT	net register ton A unit of mass equal to the total cubic footage after deductions, where 1 register ton is equal to 100 cubic feet. Refer International Convention on tonnage measurement of Ships.
NTU	Nephelometric turbidity unit Nephelometric turbidity unit (NTU) is used for water turbidity level evaluation
NU	newton metre
NX	part per thousand A unit of proportion equal to 10 to the power of -3. Synonym: per mille
OA	panel A unit of count defining the number of panels (panel: a distinct, usually rectangular, section of a surface).
ODE	ozone depletion equivalent A unit of mass defining the ozone depletion potential in kilograms of a product relative to the calculated depletion for the reference substance, Trichlorofluoromethane (CFC-11).
ODG	ODS Grams A unit of measure calculated by multiplying the mass of the substance in grams and the ozone-depleting potential for the substance.

## Used Codes

---

ODK	<p>ODS Kilograms</p> <p>A unit of measure calculated by multiplying the mass of the substance in kilograms and the ozone-depleting potential for the substance.</p>
ODM	<p>ODS Milligrams</p> <p>A unit of measure calculated by multiplying the mass of the substance in milligrams and the ozone-depleting potential for the substance.</p>
OHM	ohm
ON	ounce per square yard
ONZ	ounce (avoirdupois)
OPM	<p>oscillations per minute</p> <p>The number of oscillations per minute.</p>
OT	<p>overtime hour</p> <p>A unit of time defining the number of overtime hours.</p>
OZ	<p>ounce av</p> <p>A unit of measure equal to 1/16 of a pound or about 28.3495 grams (av = avoirdupois). Use ounce (common code ONZ).</p>
OZA	fluid ounce (US)
OZI	fluid ounce (UK)
P1	<p>percent</p> <p>A unit of proportion equal to 0.01.</p>
P10	<p>coulomb per metre</p> <p>Derived SI unit coulomb divided by the SI base unit metre.</p>
P11	<p>kiloweber</p> <p>1000 fold of the derived SI unit weber.</p>
P12	<p>gamma</p> <p>Unit of magnetic flow density.</p>
P13	<p>kilotesla</p> <p>1000-fold of the derived SI unit tesla.</p>
P14	<p>joule per second</p> <p>Quotient of the derived SI unit joule divided by the SI base unit second.</p>
P15	<p>joule per minute</p> <p>Quotient from the derived SI unit joule divided by the unit minute.</p>
P16	<p>joule per hour</p> <p>Quotient from the derived SI unit joule divided by the unit hour.</p>
P17	<p>joule per day</p> <p>Quotient from the derived SI unit joule divided by the unit day.</p>

**Used Codes**

P18	kilojoule per second Quotient from the 1000-fold of the derived SI unit joule divided by the SI base unit second.
P19	kilojoule per minute Quotient from the 1000-fold of the derived SI unit joule divided by the unit minute.
P2	pound per foot
P20	kilojoule per hour Quotient from the 1000-fold of the derived SI unit joule divided by the unit hour.
P21	kilojoule per day Quotient from the 1000-fold of the derived SI unit joule divided by the unit day.
P22	nanoohm 0,000 000 001-fold of the derived SI unit ohm.
P23	ohm circular-mil per foot Unit of resistivity.
P24	kilohenry 1000-fold of the derived SI unit henry.
P25	lumen per square foot Derived SI unit lumen divided by the power of the unit foot according to the Anglo-American and Imperial system of units by exponent 2.
P26	phot CGS (Centimetre-Gram-Second system) unit of luminance, defined as lumen by square centimetre.
P27	footcandle Non SI conform traditional unit, defined as density of light which impinges on a surface which has a distance of one foot from a light source, which shines with an intensity of an international candle.
P28	candela per square inch SI base unit candela divided by the power of unit inch according to the Anglo-American and Imperial system of units by exponent 2.
P29	footlambert Unit of the luminance according to the Anglo-American system of units, defined as emitted or reflected luminance of a lm/ft <sup>2</sup> .
P30	lambert CGS (Centimetre-Gram-Second system) unit of luminance, defined as the emitted or reflected luminance by one lumen per square centimetre.
P31	stilb CGS (Centimetre-Gram-Second system) unit of luminance, defined as emitted or reflected luminance by one lumen per square centimetre.



## Used Codes

P32	candela per square foot Base unit SI candela divided by the power of the unit foot according to the Anglo-American and Imperial system of units by exponent 2.
P33	kilocandela 1000-fold of the SI base unit candela.
P34	millicandela 0,001-fold of the SI base unit candela.
P35	Hefner-Kerze Obsolete, non-legal unit of the power in Germany relating to DIN 1301-3: 1979: 1 HK = 0,903 cd.
P36	international candle Obsolete, non-legal unit of the power in Germany relating to DIN 1301-3: 1979: 1 HK = 1,019 cd.
P37	British thermal unit (international table) per square foot Unit of the areal-related energy transmission according to the Imperial system of units.
P38	British thermal unit (thermochemical) per square foot Unit of the areal-related energy transmission according to the Imperial system of units.
P39	calorie (thermochemical) per square centimetre Unit of the areal-related energy transmission according to the Imperial system of units.
P40	langley CGS (Centimetre-Gram-Second system) unit of the areal-related energy transmission (as a measure of the incident quantity of heat of solar radiation on the earth's surface).
P41	decade (logarithmic) $1 \text{ Dec} := \log_2 10 \sim 3,32$ according to the logarithm for frequency range between $f_1$ and $f_2$ , when $f_2/f_1 = 10$ .
P42	pascal squared second Unit of the set as a product of the power of derived SI unit pascal with exponent 2 and the SI base unit second.
P43	bel per metre Unit bel divided by the SI base unit metre.
P44	pound mole Non SI-conforming unit of quantity of a substance relating that one pound mole of a chemical composition corresponds to the same number of pounds as the molecular weight of one molecule of this composition in atomic mass units.

## Used Codes

---

P45	pound mole per second Non SI-conforming unit of the power of the amount of substance non-SI compliant unit of the molar flux relating that a pound mole of a chemical composition the same number of pound corresponds like the molecular weight of a molecule of this composition in atomic mass units.
P46	pound mole per minute Non SI-conforming unit of the power of the amount of substance non-SI compliant unit of the molar flux relating that a pound mole of a chemical composition the same number of pound corresponds like the molecular weight of a molecule of this composition in atomic mass units.
P47	kilomole per kilogram 1000-fold of the SI base unit mol divided by the SI base unit kilogram.
P48	pound mole per pound Non SI-conforming unit of the material molar flux divided by the avoirdupois pound for mass according to the avoirdupois unit system.
P49	newton square metre per ampere Product of the derived SI unit newton and the power of SI base unit metre with exponent 2 divided by the SI base unit ampere.
P5	five pack A unit of count defining the number of five-packs (five-pack: set of five items packaged together).
P50	weber metre Product of the derived SI unit weber and SI base unit metre.
P51	mol per kilogram pascal SI base unit mol divided by the product of the SI base unit kilogram and the derived SI unit pascal.
P52	mol per cubic metre pascal SI base unit mol divided by the product of the power from the SI base unit metre with exponent 3 and the derived SI unit pascal.
P53	unit pole CGS (Centimetre-Gram-Second system) unit for magnetic flux of a magnetic pole (according to the interaction of identical poles of 1 dyn at a distance of a cm).
P54	milligray per second 0,001-fold of the derived SI unit gray divided by the SI base unit second.
P55	microgray per second 0,000 001-fold of the derived SI unit gray divided by the SI base unit second.
P56	nanogray per second 0,000 000 001-fold of the derived SI unit gray divided by the SI base unit second.

**Used Codes**

P57	gray per minute SI derived unit gray divided by the unit minute.
P58	milligray per minute 0,001-fold of the derived SI unit gray divided by the unit minute.
P59	microgray per minute 0,000 001-fold of the derived SI unit gray divided by the unit minute.
P60	nanogray per minute 0,000 000 001-fold of the derived SI unit gray divided by the unit minute.
P61	gray per hour SI derived unit gray divided by the unit hour.
P62	milligray per hour 0,001-fold of the derived SI unit gray divided by the unit hour.
P63	microgray per hour 0,000 001-fold of the derived SI unit gray divided by the unit hour.
P64	nanogray per hour 0,000 000 001-fold of the derived SI unit gray divided by the unit hour.
P65	sievert per second Derived SI unit sievert divided by the SI base unit second.
P66	millisievert per second 0,001-fold of the derived SI unit sievert divided by the SI base unit second.
P67	microsievert per second 0,000 001-fold of the derived SI unit sievert divided by the SI base unit second.
P68	nanosievert per second 0,000 000 001-fold of the derived SI unit sievert divided by the SI base unit second.
P69	rem per second Unit for the equivalent tin rate relating to DIN 1301-3:1979: $1 \text{ rem/s} = 0,01 \text{ J}/(\text{kg}\cdot\text{s}) = 1 \text{ Sv/s}$ .
P70	sievert per hour Derived SI unit sievert divided by the unit hour.
P71	millisievert per hour 0,001-fold of the derived SI unit sievert divided by the unit hour.
P72	microsievert per hour 0,000 001-fold of the derived SI unit sievert divided by the unit hour.
P73	nanosievert per hour 0,000 000 001-fold of the derived SI unit sievert divided by the unit hour.

**Used Codes**

P74	sievert per minute Derived SI unit sievert divided by the unit minute.
P75	millisievert per minute 0,001-fold of the derived SI unit sievert divided by the unit minute.
P76	microsievert per minute 0,000 001-fold of the derived SI unit sievert divided by the unit minute.
P77	nanosievert per minute 0,000 000 001-fold of the derived SI unit sievert divided by the unit minute.
P78	reciprocal square inch Complement of the power of the unit inch according to the Anglo-American and Imperial system of units by exponent 2.
P79	pascal square metre per kilogram Unit of the burst index as derived unit for pressure pascal related to the substance, represented as a quotient from the SI base unit kilogram divided by the power of the SI base unit metre by exponent 2.
P80	millipascal per metre 0,001-fold of the derived SI unit pascal divided by the SI base unit metre.
P81	kilopascal per metre 1000-fold of the derived SI unit pascal divided by the SI base unit metre.
P82	hectopascal per metre 100-fold of the derived SI unit pascal divided by the SI base unit metre.
P83	standard atmosphere per metre Outdated unit of the pressure divided by the SI base unit metre.
P84	technical atmosphere per metre Obsolete and non-legal unit of the pressure which is generated by a 10 metre water column divided by the SI base unit metre.
P85	torr per metre CGS (Centimetre-Gram-Second system) unit of the pressure divided by the SI base unit metre.
P86	psi per inch Compound unit for pressure (pound-force according to the Anglo-American unit system divided by the power of the unit inch according to the Anglo-American and Imperial system of units with the exponent 2) divided by the unit inch according to the Anglo-American and Imperial system of units .
P87	cubic metre per second square metre Unit of volume flow cubic meters by second related to the transmission surface in square metres.
P88	rhe Non SI-conforming unit of fluidity of dynamic viscosity.

## Used Codes

P89	pound-force foot per inch Unit for length-related rotational moment according to the Anglo-American and Imperial system of units.
P90	pound-force inch per inch Unit for length-related rotational moment according to the Anglo-American and Imperial system of units.
P91	perm (0 °C) Traditional unit for the ability of a material to allow the transition of the steam, defined at a temperature of 0 °C as steam transmittance, where the mass of one grain steam penetrates an area of one foot squared at a pressure from one inch mercury per hour.
P92	perm (23 °C) Traditional unit for the ability of a material to allow the transition of the steam, defined at a temperature of 23 °C as steam transmittance at which the mass of one grain of steam penetrates an area of one square foot at a pressure of one inch mercury per hour.
P93	byte per second Unit byte divided by the SI base unit second.
P94	kilobyte per second 1000-fold of the unit byte divided by the SI base unit second.
P95	megabyte per second 1 000 000-fold of the unit byte divided by the SI base unit second.
P96	reciprocal volt Reciprocal of the derived SI unit volt.
P97	reciprocal radian Reciprocal of the unit radian.
P98	pascal to the power sum of stoichiometric numbers Unit of the equilibrium constant on the basis of the pressure(ISO 80000-9: 2009, 9-35.a).
P99	mole per cubiv metre to the power sum of stoichiometric numbers Unit of the equilibrium constant on the basis of the concentration (ISO 80000-9:2009, 9-36.a).
PAL	pascal
PD	pad A unit of count defining the number of pads (pad: block of paper sheets fastened together at one end).
PFL	proof litre A unit of volume equal to one litre of proof spirits, or the alcohol equivalent thereof. Used for measuring the strength of distilled alcoholic liquors, expressed as a percentage of the alcohol content of a standard mixture at a specific temperature.

## Used Codes

---

PGL	proof gallon A unit of volume equal to one gallon of proof spirits, or the alcohol equivalent thereof. Used for measuring the strength of distilled alcoholic liquors, expressed as a percentage of the alcohol content of a standard mixture at a specific temperature.
PI	pitch A unit of count defining the number of characters that fit in a horizontal inch.
PLA	degree Plato A unit of proportion defining the sugar content of a product, especially in relation to beer.
PO	pound per inch of length
PQ	page per inch A unit of quantity defining the degree of thickness of a bound publication, expressed as the number of pages per inch of thickness.
PR	pair A unit of count defining the number of pairs (pair: item described by two's).
PS	pound-force per square inch
PT	pint (US) Use liquid pint (common code PTL)
PTD	dry pint (US)
PTI	pint (UK)
PTL	liquid pint (US)
PTN	portion A quantity of allowance of food allotted to, or enough for, one person.
Q10	joule per tesla Unit of the magnetic dipole moment of the molecule as derived SI unit joule divided by the derived SI unit tesla.
Q11	erlang Unit of the market value according to the feature of a single feature as a statistical measurement of the existing utilization.
Q12	octet Synonym for byte: 1 octet = 8 bit = 1 byte.
Q13	octet per second Unit octet divided by the SI base unit second.
Q14	shannon Logarithmic unit for information equal to the content of decision of a sentence of two mutually exclusive events, expressed as a logarithm to base 2.

## Used Codes

---

Q15	hartley Logarithmic unit for information equal to the content of decision of a sentence of ten mutually exclusive events, expressed as a logarithm to base 10.
Q16	natural unit of information Logarithmic unit for information equal to the content of decision of a sentence of ,718 281 828 459 mutually exclusive events, expressed as a logarithm to base Euler value e.
Q17	shannon per second Time related logarithmic unit for information equal to the content of decision of a sentence of two mutually exclusive events, expressed as a logarithm to base 2.
Q18	hartley per second Time related logarithmic unit for information equal to the content of decision of a sentence of ten mutually exclusive events, expressed as a logarithm to base 10.
Q19	natural unit of information per second Time related logarithmic unit for information equal to the content of decision of a sentence of 2,718 281 828 459 mutually exclusive events, expressed as a logarithm to base of the Euler value e.
Q20	second per kilogramm Unit of the Einstein transition probability for spontaneous or inducing emissions and absorption according to ISO 80000-7:2008, expressed as SI base unit second divided by the SI base unit kilogram.
Q21	watt square metre Unit of the first radiation constants $c_1 = 2 \cdot p \cdot h \cdot c_0$ to the power of 2, the value of which is 3,741 771 18·10 <sup>16</sup> -fold that of the comparative value of the product of the derived SI unit watt multiplied with the power of the SI base unit metre with the exponent 2.
Q22	second per radian cubic metre Unit of the density of states as an expression of angular frequency as complement of the product of hertz and radian and the power of SI base unit metre by exponent 3 .
Q23	weber to the power minus one Complement of the derived SI unit weber as unit of the Josephson constant, which value is equal to the 384 597,891-fold of the reference value gigahertz divided by volt.
Q24	reciprocal inch Complement of the unit inch according to the Anglo-American and Imperial system of units.
Q25	dioptre Unit used at the statement of relative refractive indexes of optical systems as complement of the focal length with correspondence to: 1 dpt = 1/m.

**Used Codes**

Q26	one per one Value of the quotient from two physical units of the same kind as a numerator and denominator whereas the units are shortened mutually.
Q27	newton metre per metre Unit for length-related rotational moment as product of the derived SI unit newton and the SI base unit metre divided by the SI base unit metre.
Q28	kilogram per square metre pascal second Unit for the ability of a material to allow the transition of steam.
Q29	microgram per hectogram Microgram per hectogram.
Q3	meal A unit of count defining the number of meals (meal: an amount of food to be eaten on a single occasion).
Q30	pH (potential of Hydrogen) The activity of the (solvated) hydrogen ion (a logarithmic measure used to state the acidity or alkalinity of a chemical solution).
Q31	kilojoule per gram
Q32	femtolitre
Q33	picolitre
Q34	nanolitre
Q35	megawatts per minute A unit of power defining the total amount of bulk energy transferred or consumer per minute.
Q36	square metre per cubic metre A unit of the amount of surface area per unit volume of an object or collection of objects.
Q37	Standard cubic metre per day Standard cubic metre (temperature 15°C and pressure 1013.25 millibars ) per day
Q38	Standard cubic metre per hour Standard cubic metre (temperature 15°C and pressure 1013.25 millibars ) per hour
Q39	Normalized cubic metre per day Normalized cubic metre (temperature 0°C and pressure 1013.25 millibars ) per day
Q40	Normalized cubic metre per hour Normalized cubic metre (temperature 0°C and pressure 1013.25 millibars ) per hour



## Used Codes

---

Q41	Joule per normalised cubic metre Joule per normalised cubic metre (temperature 0°C and pressure 1013.25 millibars).
Q42	Joule per standard cubic metre Joule per standard cubic metre (temperature 15°C and pressure 1013.25 millibars).
QA	page - facsimile A unit of count defining the number of facsimile pages.
QAN	quarter (of a year) A unit of time defining the number of quarters (3 months).
QB	page - hardcopy A unit of count defining the number of hardcopy pages (hardcopy page: a page rendered as printed or written output on paper, film, or other permanent medium).
QR	quire A unit of count for paper, expressed as the number of quires (quire: a number of paper sheets, typically 25).
QT	quart (US) Use liquid quart (common code QTL)
QTD	dry quart (US)
QTI	quart (UK)
QTL	liquid quart (US)
QTR	quarter (UK) A traditional unit of weight equal to 1/4 hundredweight. In the United Kingdom, one quarter equals 28 pounds.
R1	pica A unit of count defining the number of picas. (pica: typographical length equal to 12 points or 4.22 mm (approx.)).
R9	thousand cubic metre A unit of volume equal to one thousand cubic metres.
RH	running or operating hour A unit of time defining the number of hours of operation.
RM	ream A unit of count for paper, expressed as the number of reams (ream: a large quantity of paper sheets, typically 500).
ROM	room A unit of count defining the number of rooms.

## Used Codes

---

RP	pound per ream A unit of mass for paper, expressed as pounds per ream. (ream: a large quantity of paper, typically 500 sheets).
RPM	revolutions per minute Refer ISO/TC12 SI Guide
RPS	revolutions per second Refer ISO/TC12 SI Guide
RT	revenue ton mile A unit of information typically used for billing purposes, expressed as the number of revenue tons (revenue ton: either a metric ton or a cubic metres, whichever is the larger), moved over a distance of one mile.
S3	square foot per second Synonym: foot squared per second
S4	square metre per second Synonym: metre squared per second (square metres/second US)
SAN	half year (6 months) 'A unit of time defining the number of half years (6 months).
SCO	score A unit of count defining the number of units in multiples of 20.
SCR	scruple
SEC	second [unit of time]
SET	set A unit of count defining the number of sets (set: a number of objects grouped together).
SG	segment A unit of information equal to 64000 bytes.
SHT	shipping ton A unit of mass defining the number of tons for shipping.
SIE	siemens
SM3	Standard cubic metre Standard cubic metre (temperature 15°C and pressure 1013.25 millibars )
SMI	mile (statute mile)
SQ	square A unit of count defining the number of squares (square: rectangular shape).
SQR	square, roofing A unit of count defining the number of squares of roofing materials, measured in multiples of 100 square feet.

## Used Codes

SR	strip A unit of count defining the number of strips (strip: long narrow piece of an object).
STC	stick A unit of count defining the number of sticks (stick: slender and often cylindrical piece of a substance).
STI	stone (UK)
STK	stick, cigarette A unit of count defining the number of cigarettes in the smallest unit for stock-taking and/or duty computation.
STL	standard litre A unit of volume defining the number of litres of a product at a temperature of 15 degrees Celsius, especially in relation to hydrocarbon oils.
STN	ton (US) or short ton (UK/US) Synonym: net ton (2000 lb)
STW	straw A unit of count defining the number of straws (straw: a slender tube used for sucking up liquids).
SW	skein A unit of count defining the number of skeins (skein: a loosely-coiled bundle of yarn or thread).
SX	shipment A unit of count defining the number of shipments (shipment: an amount of goods shipped or transported).
SYR	syringe A unit of count defining the number of syringes (syringe: a small device for pumping, spraying and/or injecting liquids through a small aperture).
T0	telecommunication line in service A unit of count defining the number of lines in service.
T3	thousand piece A unit of count defining the number of pieces in multiples of 1000 (piece: a single item, article or exemplar).
TAH	kiloampere hour (thousand ampere hour)
TAN	total acid number A unit of chemistry defining the amount of potassium hydroxide (KOH) in milligrams that is needed to neutralize the acids in one gram of oil. It is an important quality measurement of crude oil.
TI	thousand square inch

**Used Codes**

TIC	metric ton, including container A unit of mass defining the number of metric tons of a product, including its container.
TIP	metric ton, including inner packaging A unit of mass defining the number of metric tons of a product, including its inner packaging materials.
TKM	tonne kilometre A unit of information typically used for billing purposes, expressed as the number of tonnes (metric tons) moved over a distance of one kilometre.
TMS	kilogram of imported meat, less offal A unit of mass equal to one thousand grams of imported meat, disregarding less valuable by-products such as the entrails.
TNE	tonne (metric ton) Synonym: metric ton
TP	ten pack A unit of count defining the number of items in multiples of 10.
TPI	teeth per inch The number of teeth per inch.
TPR	ten pair A unit of count defining the number of pairs in multiples of 10 (pair: item described by two's).
TQD	thousand cubic metre per day A unit of volume equal to one thousand cubic metres per day.
TRL	trillion (EUR)
TST	ten set A unit of count defining the number of sets in multiples of 10 (set: a number of objects grouped together).
TTS	ten thousand sticks A unit of count defining the number of sticks in multiples of 10000 (stick: slender and often cylindrical piece of a substance).
U1	treatment A unit of count defining the number of treatments (treatment: subjection to the action of a chemical, physical or biological agent).
U2	tablet A unit of count defining the number of tablets (tablet: a small flat or compressed solid object).
UA	torr
UB	telecommunication line in service average A unit of count defining the average number of lines in service.

## Used Codes

---

UC	telecommunication port A unit of count defining the number of network access ports.
UIG	international unit per gram A unit of count defining the number of international units per gram.
VA	volt - ampere per kilogram
VLT	volt
VP	percent volume A measure of concentration, typically expressed as the percentage volume of a solute in a solution.
W2	wet kilo A unit of mass defining the number of kilograms of a product, including the water content of the product.
WA	watt per kilogram
WB	wet pound A unit of mass defining the number of pounds of a material, including the water content of the material.
WCD	cord A unit of volume used for measuring lumber. One board foot equals 1/12 of a cubic foot.
WE	wet ton A unit of mass defining the number of tons of a material, including the water content of the material.
WEB	weber
WEE	week
WG	wine gallon A unit of volume equal to 231 cubic inches.
WHR	watt hour
WM	working month A unit of time defining the number of working months.
WSD	standard A unit of volume of finished lumber equal to 165 cubic feet. Synonym: standard cubic foot
WTT	watt
WW	millilitre of water A unit of volume equal to the number of millilitres of water.
X1	Gunter's chain A unit of distance used or formerly used by British surveyors.
YDK	square yard

**Used Codes**

YDQ	cubic yard
YRD	yard
Z11	hanging container A unit of count defining the number of hanging containers.
Z9	nanomole An SI unit of amount of substance equal to 10 <sup>-9</sup> moles
ZP	page A unit of count defining the number of pages.
ZZ	mutually defined A unit of measure as agreed in common between two or more parties.
001	Barrel (205 litres, 45 gallons) (GS1 Temporary Code) A unit of liquids equivalent to 205 litres or 45 gallons.
23	gram per cubic centimetre GS1 Description: g/cm <sup>3</sup> as a unit of measure for the density of gas. This is necessary for dangerous substance articles for determination of the quantities that can be stored together on the shelf.
25	gram per square centimetre GS1 Description: A measure of weight in terms of gram per square centimetre.
28	kilogram per square metre GS1 Description: Unit of measure expressed in kilogram per square metre.
37	ounce per square foot
59	part per million
64	Pound per square inch, gauge A unit of measure expressed in pound per square inch
2N	decibel
2X	metre per minute GS1 Description: A measure of speed in terms of metres per minute.
4K	milliampere
4L	megabyte GS1 Description: A unit of computer memory equal to 1.048.576 (i.e. 2 power 20) bytes.
40	microfarad GS1 Description: One millionth of a farad. A farad is the capacitance of a capacitor between the plates of which a potential of 1 volt is created by a charge of 1 Coulomb.
4P	newton per metre

**Used Codes**

A25	cheval vapeur
A86	gigahertz GS1 Description: Hertz multiplied by 10*9.
A99	Bit A unit of information equal to one binary digit.
ACR	acre GS1 Description: Acre (4840 yd2)
AD	byte GS1 Description: A unit of information stored in a computer, equal to eight bits.
AMH	ampere hour GS1 Description: Ampere-hour (3,6kC)
AMP	ampere
AMT	amount
ANN	year GS1 Description: The expression of a year as a measure unit.
APZ	Troy ounce or apothecary ounce EDIFACT
ASM	alcoholic strength by mass GS1 Description: Alcoholic strength expressed by mass.
ASU	alcoholic strength by volume GS1 Description: Alcoholic strength expressed by volume.
AV	capsule GS1 Description: Encapsuled dosage form for pharmaceuticals.
B13	Joule per square metre A unit of measure of heat energy expressed in joule per square metre.
B17	Credit A unit of count defining the number of entries made to the credit side of an account.
BAR	bar GS1 Description: A unit of measure equal to 106 dines per square centimeter.
BTU	British thermal unit GS1 Description: British thermal unit (1,055 kilojoules)

**Used Codes**

C0	call GS1 Description: Unit of measure for telephone calls. Code value is C0 (C Zero).
C60	ohm centimetre GS1 Description: Unit of measure expressed in Ohm centimetre.
C79	Kilovolt Ampere Hour A unit of accumulated energy of 1000 volt amperes over a period of one hour. EDIFACT
CDL	candela GS1 Description: Unit of measure of light intensity.
CEL	degree celsius
CF2	Colony forming unit per gram (GS1 Temporary Code) Colony forming units per gram is a unit of measure for micro-organisms, such as bacteria, in a food item. Micro-organisms form colonies that are be counted under determined conditions
CLT	centilitre GS1 Description: A unit of volume equal to one hundredth of a liter.
CMK	square centimetre
CMQ	cubic centimetre GS1 Description: A system of units for the measurement of volume based on the cubic centimetre.
CMT	centimetre
D19	Square metre kelvin per watt Unit of measure of thermal insulance expressed in square metre kelvin per watt.
D21	square metre per kilogram GS1 Description: Unit of measure expressed in square metre per kilogram.
D32	Terawatt hour A unit of measure expressed in terawatt hour
D5	Kilogram per square centimetre A unit of measure expressed in kilogram per square centimetre
D55	Watt per square metre kelvin Unit of measure of thermal conductance expressed in watt per square metre kelvin.
D68	Number of Words A unit of count defining the number of words. EDIFACT



**Used Codes**

DAY	day GS1 Description: The expression of a day as a measure unit.
DD	degree GS1 Description: Unit of measure of temperature.
DMQ	cubic decimetre GS1 Description: Unit of measure expressed in cubic decimetre.
DMT	decimetre
DRG	Dragée (GS1 Temporary Code) Number of dragées (coated tablets) contained in the item's package as a measurement unit.
DZN	dozen GS1 Description: A unit of measure of 12 or group of 12.
E09	Milliampere hour A unit of power load delivered at the rate of one thousandth of an ampere over a period of one hour. EDIFACT
E10	Degree day A unit of measure used in meteorology and engineering to measure the demand for heating or cooling over a given period of days. EDIFACT
E11	Gigacalorie A unit of heat energy equal to one thousand million calories. EDIFACT
E27	Dose A unit of count defining the number of doses (dose: a definite quantity of a medicine or drug). EDIFACT
E31	Square metre per litre A unit of count defining the number of square metres per litre. EDIFACT
E32	Litre per hour A unit of count defining the number of litres per hour. EDIFACT
E34	Gigabyte A unit of information equal to 10 E9 bytes.
E37	Pixel A unit of count defining the number of pixels (pixel: picture element).

**Used Codes**

E38	Megapixel A unit of count equal to 10 E6 (1000000) pixels (picture elements).
E39	Dots per inch A unit of information defining the number of dots per linear inch as a measure of the resolution or sharpness of an image. GS1 Description: synonym: pixels per inch.
EA	each
EV	envelope GS1 Description: A unit of measure pertaining to the number of envelopes.
FAH	degree Fahrenheit
FOT	foot GS1 Description: Foot (0,3048 m)
FP	Pound per square foot A unit of measure expressed in pound per square foot
FTK	Square foot A unit of measure expressed in square foot
FTQ	cubic foot
GL	gram per litre
GLI	gallon (UK) GS1 Description: Gallon (4,546092 dm <sup>3</sup> )
GM	gram per square metre GS1 Description: Unit of measure of grams per square metre.
GRM	gram
GRO	gross GS1 Description: A unit of measure of 12 dozens.
GV	gigajoule
GWH	gigawatt hour GS1 Description: Gigawatt-hour (1 million kW/h)
H87	Piece A unit of count defining the number of pieces (piece: a single item, article or exemplar). EDIFACT
HLT	hectolitre

**Used Codes**

HMT	hectometre A unit of linear measure equal to 10 E2 metres.
HTZ	hertz GS1 Description: One cycle per second.
HUR	hour
INH	inch GS1 Description: Inch (25,4 mm)
INK	Square inch A unit of measure expressed in square inch
JM	Megajoule per cubic metre EDIFACT
JOU	joule
K51	Kilocalorie (mean) EDIFACT
KB	kilocharacter
KBA	kilobar
KEL	kelvin
KGM	kilogram
KHZ	kilohertz
KJO	kilojoule
KL	kilogram per metre GS1 Description: A measure of weight in terms of kilogram per metre.
KMH	kilometre per hour GS1 Description: A unit of measure expressed in kilometre per hour.
KMQ	kilogram per cubic metre GS1 Description: A measure of weight in terms of kilogram per cubic metre.
KMT	kilometre
KPA	kilopascal GS1 Description: Unit of measure expressed in kilopascal.
KVA	kilovolt - ampere GS1 Description: A unit of electric power.
KVT	kilovolt
KWH	kilowatt hour

**Used Codes**

KWT	kilowatt
L2	litre per minute GS1 Description: Unit of measure expressed in litre per minute.
LBR	Pound EDIFACT
LD	Litre per day A unit of measure defining the number of litres per day.
LNE	Printed line count (GS1 Temporary Code) The indication of the count of printed lines included on a paper communication (e.g. telegram) for invoicing purposes.
LTR	litre GS1 Description: Litre (1 dm <sup>3</sup> )
LUX	lux GS1 Description: Unit of measure of illumination (it corresponds to the illumination of a surface which normally and uniformly receives a light flow of 1 lumen per square meter).
M4	Monetary value A unit of measure expressed as a monetary amount. EDIFACT
MAL	mega litre
MAW	megawatt
MC	microgram One millionth of a gram.
MCU	millicurie GS1 Description: Unit of measure for radioactivity.
MGM	milligram
MHZ	megahertz
MIN	minute
MLT	millilitre
MMK	square millimetre GS1 Description: A unit to measure a surface equal to one millionth of a quadrate.
MMQ	cubic millimetre GS1 Description: A unit of measure expressed in cubic milimetres.
MMT	millimetre

**Used Codes**

MON	month GS1 Description: The expression of a month as a measure unit.
MPA	megapascal GS1 Description: A unit of measure expressed in Megapascal.
MQH	Cubic metre per hour A unit of measure defining the number of cubic metres per hour.
MTK	square metre
MTQ	cubic metre
MTR	metre
MTS	Metre per second A unit of speed expressed in metres per second.
MWH	megawatt hour (1000 kW.h)
NAR	number of articles
NEW	newton GS1 Description: The SI unit of force, equal to the force that would give a mass of one kilogram an acceleration of one metre per second.
NIU	number of international units A unit of count defining the number of international units.
NRL	number of rolls
ONZ	ounce GS1 Description: Ounce GB, US (28,349523 g)
OZA	fluid ounce (US) GS1 Description: Fluid ounce US (29,5735 cm <sup>3</sup> )
OZI	fluid ounce (UK) GS1 Description: Fluid ounce UK (28,413 cm <sup>3</sup> )
P1	percent GS1 Description: This code is used to indicate measurements in terms of percentages, e.g. the relative humidity (code RA in data element 6313) is 52%.
PA	packet
PAL	pascal GS1 Description: The SI unit of pressure, equal to one Newton per square metre.
PCE	Piece (GS1 Temporary Code) GS1 Note: Old code value. Use value H87 instead.

**Used Codes**

PF	pallet (lift) GS1 Description: A number of articles expressed in terms of pallets.
PR	pair GS1 Description: Two articles which belong together but are not necessarily identical.
PTI	pint (UK) GS1 Description: Pint UK (0,568262 dm3)
PTN	Portion (GS1 Temporary Code) The identification of the number of portions (doses in medical terms) into which a complete product may be broken into for serving purposes, e.g. a pie with 6 portions, a liquid medicine with 20 doses.
QAN	quarter (of a year)
QTI	quart (UK) GS1 Description: Quart UK (1,1136523 dm3)
RJH	Decanewton (GS1 Temporary Code) A unit of force equal to 10 Newton.
RPM	revolutions per minute
RTO	Ratio (GS1 Temporary Code) The measured value is a ratio.
SEC	second
SMI	Mile (statute mile) A unit of measure expressed in mile
ST	sheet
TNE	tonne (metric ton) GS1 Description: Metric ton (1000kg)
U2	tablet A unit of count defining the number of tablets (tablet: a small flat or compressed solid object). GS1 Description: Dosage form for pharmaceuticals, pressed or compacted from a powder into a solid dose.
UI	Unit of activity, predefined (GS1 Temporary Code) A measure pertaining to a predefined activity.
VI	vial GS1 Description: Small glass container. E.g. for a liquid medicine or perfume.
VLT	volt

## Used Codes

WHR	watt hour
WTT	watt
YDK	Square yard A unit of measure expressed in square yard
YRD	yard GS1 Description: Yard (0,9144 m)
ZP	page GS1 Description: The indication of a page as a measurement unit for invoicing purposes, e.g. fax pages.
<b>7143</b>	Item type identification code Coded identification of an item type.
AA	Product version number Number assigned by manufacturer or seller to identify the release of a product.
AC	HIBC (Health Industry Bar Code) Article identifier used within health sector to indicate data used conforms to HIBC.
AQ	Coupon number GS1 Description: A number identifying a coupon which is attached to the identified product.
AT	Price look up number Identification number on a product allowing a quick electronic retrieval of price information for that product.
ATC	Therapeutic classification number (GS1 Temporary Code) A code to specify a product's therapeutic classification.
BAN	Base article node number (GS1 Temporary Code) A number which identifies a node within a base article configuration.
BB	Lot number A number indicating the lot number of a product.
BP	Buyer's part number Reference number assigned by the buyer to identify an article. GS1 Description: Reference number assigned by the buyer to identify an article. GS1 usage note: As the code values 'BP' and 'IN' are defined in the same way, it is recommended that the code value 'IN' be used to specify any article numbers assigned by the buyer.
BRI	Brick Code (GS1 Temporary Code) Global GS1 classification category code. Unique, permanent 10-digit key.

## Used Codes

---

BU	Dye lot number Number identifying a dye lot.
BZ	Original equipment number Original equipment number allocated to spare parts by the manufacturer.
CG	Commodity grouping Code for a group of articles with common characteristics (e.g. used for statistical purposes).
DW	Drawing Reference number identifying a drawing of an article.
ECP	ECLASS property (GS1 Temporary Code) Unique code which identifies the ECLASS classification property.
ECV	ECLASS property value (GS1 Temporary Code) Value for a property according to the ECLASS classification.
EWC	European Waste Catalogue (GS1 Temporary Code) Waste type number according to the European Waste Catalogue (EWC).
FS	Fish species Identification of fish species.
GAT	GPC Brick attribute type (GS1 Temporary Code) Unique 8 digit code which identifies the Global GS1 classification.
GAV	GPC brick attribute value (GS1 Temporary Code) Unique 8 digit code which identifies the Global GS1 classification attribute value
GB	Buyer's internal product group code Product group code used within a buyer's internal systems.
GD	Industry sector article group number/product classification code (GS1 Temporary Code) Sectoral product group or classification identification code. Administered by a sector specific agency.
GLN	Global Location Number (GS1 Temporary Code) Unique location number assigned by a Member Organisation of GS1.
GMN	Global Model Number The GMN is the GS1-identification key used to identify a product model or product family based on attributes common to the model or family as defined by industry or regulation.
GN	National product group code National product group code. Administered by a national agency.



## Used Codes

GU	Supplier's internal article group number/product classification code (GS1 Temporary Code) Product group or classification identification code within a supplier's internal system.
HS	Harmonised system The item number is part of, or is generated in the context of the Harmonised Commodity Description and Coding System (Harmonised System), as developed and maintained by the World Customs Organization (WCO).
IB	ISBN (International Standard Book Number) Self explanatory.
IN	Buyer's item number The item number has been allocated by the buyer.
IS	ISSN (International Standard Serial Number) Self explanatory.
IT	Buyer's style number Number given by the buyer to a specific style or form of an article, especially used for garments.
LI	Line item number (GS1 Temporary Code) Number identifying a specific line within a document/message.
MF	Manufacturer's (producer's) article number The number given to an article by its manufacturer.
MN	Model number Reference number assigned by the manufacturer to differentiate variations in similar products in a class or group.
NB	Batch number The item number is a batch number. GS1 Description: Number supplementing the identification code of a product used to identify the specific production place and/or time of a product.
PGC	Price grouping code (GS1 Temporary Code) Number assigned to identify a grouping of products based on price.
PV	Promotional variant number The item number is a promotional variant number. GS1 Description: Number supplementing the identification code of a product and identifying that product as a variant of the standard product. To be used when the variation is not sufficiently significant to justify a change to the main identification code of the product.
RVM	Restricted circulation variable measure number (GS1 Temporary Code) A number assigned to identify a restricted circulation variable measure item.

## Used Codes

---

SA	Supplier's article number Number assigned to an article by the supplier of that article.
SN	Serial number Identification number of an item which distinguishes this specific item out of a number of identical items.
SPP	Standard product also used in promotions (GS1 Temporary Code) Article number of a standard product which may temporarily also be used for promotional purposes, e.g. the physical product or price of the product does not change but a christmas tree is marked on the packaging to decorate the product for christmas.
SRS	RSK number Plumbing and heating.
SRT	IFLS (Institut Francais du Libre Service) 5 digit product classification code 5 digit code for product classification managed by the Institut Francais du Libre Service.
SRU	IFLS (Institut Francais du Libre Service) 9 digit product classification code 9 digit code for product classification managed by the Institut Francais du Libre Service.
SRV	GS1 Global Trade Item Number A unique number, up to 14-digits, assigned according to the numbering structure of the GS1 system. 'GS1' stands for the 'Global Standards One'.
SRX	Slaughter number Unique number given by a slaughterhouse to an animal or a group of animals of the same breed. EDIFACT
SSS	Distributor's article identifier Identifier assigned to an article by the distributor of that article.
SST	Norwegian Classification system ENVA Product classification system used in the Norwegian market. EDIFACT
SSU	Supplier assigned Product classification assigned by the supplier. EDIFACT
SSV	Mexican classification system AMECE Product classification system used in the Mexican market. EDIFACT
SSW	German classification system CCG Product classification system used in the German market. EDIFACT

## Used Codes

SSX	Finnish classification system EANFIN Product classification system used in the Finnish market. EDIFACT
SSY	Canadian classification system ICC Product classification system used in the Canadian market. EDIFACT
SSZ	Dutch classification system CBL Product classification system used in the Dutch market. EDIFACT
ST	Style number Number given to a specific style or form of an article, especially used for garments.
STA	Dutch classification system CBL Product classification system used in the Dutch market.
STB	Japanese classification system JICFS Product Classification system used in the Japanese market.
STC	European Union dairy subsidy eligibility classification Category of product eligible for EU subsidy (applies for certain dairy products with specific level of fat content).
STD	GS1 Spain Classification Product classification system used in the Spanish Market.
STE	GS1 Poland classification system Product classification system used in the Polish market.
STF	Federal Agency on Technical Regulating and Metrology of the Russian Federation A Russian government agency that serves as a national standardization body of the Russian Federation.
STG	Efficient Consumer Response (ECR) Austria classification system Product classification system used in the Austrian market.
STH	GS1 Italy classification system Product classification system used in the Italian market
STI	CPV (Common Procurement Vocabulary) Official classification system for public procurement in the European Union.
STJ	IFDA (International Foodservice Distributors Association) International Foodservice Distributors Association (IFDA).
STK	AHFS (American Hospital Formulary Service) pharmacologic therapeutic classification. Pharmacologic therapeutic classification maintained by the American Hospital Formulary Service (AHFS).

## Used Codes

STL	ATC (Anatomical Therapeutic Chemical) classification system Anatomical Therapeutic Chemical classification system maintained by the World Health Organisation (WHO).
STM	CLADIMED (Classification des Dispositifs Médicaux) A five level classification system for medical devices maintained by the CLADIMED organisation used in the French market.
STN	CMDR (Canadian Medical Device Regulations) classification system Classification system related to the Canadian Medical Device Regulations maintained by Health Canada.
STO	CNDM (Classificazione Nazionale dei Dispositivi Medici) A classification system for medical devices used in the Italian market.
STP	UK DM&D (Dictionary of Medicines & Devices) standard coding scheme A classification system for medicines and devices use in the UK market.
STQ	ECLASS Standardized material and service classification and dictionary maintained by ECLASS e.V.
STR	EDMA (European Diagnostic Manufacturers Association) Products Classification Classification for in vitro diagnostics medical devices maintained by the European Diagnostic Manufacturers Association.
STS	EGAR (European Generic Article Register) A classification system for medical devices.
STT	GMDN (Global Medical Devices Nomenclature) Nomenclature system for identification of medical devices officially approved by the European Union.
STU	GPI (Generic Product Identifier) A drug classification system managed by Medi-Span.
STV	HCPCS (Healthcare Common Procedure Coding System) A classification system used with US healthcar insurance programs.
STW	ICPS (International Classification for Patient Safety) A patient safety taxonomy maintained by the World Health Organisation.
STX	MedDRA (Medical Dictionary for Regulatory Activities) A medical dictionary maintained by the International Federation of Pharmaceutical Manufacturers and Associations (IFPMA).
STY	Medical Columbus Medical product classification system used in the German market.
STZ	NAPCS (North American Product Classification System) Product classification system used in the North American market.
SUA	NHS (National Health Services) eClass Product and Service classification system used in United Kingdom market.

## Used Codes

---

SUB	US FDA (Food and Drug Administration) Product Code Classification Database US FDA Product Code Classification Database contains medical device names and associated information developed by the Center for Devices and Radiological Health (CDRH).
SUC	SNOMED CT (Systematized Nomenclature of Medicine-Clinical Terms) A medical nomenclature system developed between the NHS and the College of American Pathologists.
SUD	UMDNS (Universal Medical Device Nomenclature System) A standard international nomenclature and computer coding system for medical devices maintained by the Emergency Care Research Institute (ECRI).
SUE	GS1 Global Returnable Asset Identifier, non-serialised A unique, 13-digit number assigned according to the numbering structure of the GS1 system and used to identify a type of Reusable Transport Item (RTI).
SUF	IMEI The International Mobile Station Equipment Identity (IMEI) is a unique number to identify mobile phones. It includes the origin, model and serial number of the device. The structure is specified in 3GPP TS 23.003.
UA	Ultimate customer's article number Number assigned by ultimate customer to identify relevant article.
X10	Lottery game number (GS1 Temporary Code) The number of a lottery game.
X11	Lottery pack book number (GS1 Temporary Code) The number of a lottery pack book.
X12	NABCA product code (GS1 Temporary Code) NABCA code identifying alcoholic beverage brands and sizes.
X13	Waste type number (GS1 Temporary Code) Identification of the type of item number. Notes: User or association defined code. May be used in combination with 1131/3055.
X2	Ear-tag number (GS1 Temporary Code) Unique number given by a national authority to identify an animal individually.
<b>7187</b>	Process type description code Code specifying a type of process.
8	Processing of structured information The information to be processed is in structured form.
9	Processing of identical information in structured and unstructured form The information to be processed is identical and given in structured and unstructured form.

## Used Codes

---

10	Processing of different information in structured and unstructured form The information to be processed is different and is given in structured and unstructured form.
11	Processing of unstructured information The information to be processed is in unstructured form.
XX1	Processing of orders at the supplier (GS1 Temporary Code) Orders process by the supplier.
XX2	Processing of orders at the retailer (GS1 Temporary Code) Orders process by the retailer.
<b>7293</b>	Sector area identification code qualifier Code qualifying identification of a subject area.
25	Banking sector Conditions apply to the banking sector.
<b>7365</b>	Processing indicator description code Code specifying a processing indicator.
10	Declaration requested Declaration is requested.
37	Complete information Processing of information to note that complete data details (not just changes) are transmitted.



## Example

---

FTX+AAG+++BEWARE EMBARGO PAYMENTS+EN'
DTM+2:X:102'
DTM+175:200206171000:203'
GIS+10:23:2:8'
GIS+10'
MOA+139:122.34:EUR:11'
MOA+139:430000:EUR:11'
LOC+39+BE:23:2:X+++X'
LOC+39+BE::5'
NAD+RA+272971234::9+X:::X+X:X:X:X:X:1+X:X:X:X+X+X:23:2:X+X+AD'
NAD+RA+5422331123459::9'
RCS+25+AB1:23:86:X'
RCS+25+AB1::86'
FTX+REG++1E:23:2+X:X:X:X:X+AA'
FTX+REG+++SUBJECT TO EUROPEAN CENTRAL BANK REGULATIONS'
PRC+11'
PRC+11'
FTX+AAG++1E:23:2+BEWARE EMBARGO PAYMENTS:X:X:X:X+EN'
FTX+PMD+++EMBARGO PAYMENT RESTRICTIONS IN FORCE+EN'
SEQ++1'
SEQ++1'
MOA+9:122.34:EUR'
MOA+9:430000:EUR'
DTM+434:19980831:102'
DTM+XF2:20000126:102'
RFF+CR:12345'
RFF+ANZ:43155836'
FCA+13+X:23:2:X:ARS'
FCA+15+DRESDEFF666:25:5'
FII+DBB+12345:N GEISS:X:USD+BK:23:2:50040000:25:2:X:X+AD'
FII+DBB+994-3277711:N GEISS'
NAD+BY+123456789:23:2+X:::X+X:X:X:X:X:1+X:X:X:X+X+X:23:2:X+X+AD'
INP+3:5+1:AD::2:X'
INP+8+2:AD'
FTX+AAG++1E:23:2+BEWARE EMBARGO PAYMENTS:X:X:X:X+EN'
FTX+AAG+++EMBARGO REGULATIONS+EN'
DTM+2:X:2'
DTM+175:200006171000:203'
GIS+10'
GIS+10'
MOA+139:122.34:EUR:11'
MOA+9:430000:EUR:11'
LOC+39+BE:23:2:X++LONDEC:23:2:X'



## Example

---

LOC+39+BE'
NAD+RA+272971234:23:2+X:::X+X:X:X:X:X:1+X:X:X:X+X:23:2:X+X+AD'
NAD+RA+5422331123459::9'
RCS+25+AB1:23:86:X'
RCS+25+AB1::86'
FTX+REG++1E:23:2+X:X:X:X+AA'
FTX+REG+++SUBJECT TO NATIONAL JURISDICTION'
PRC+10:23:2:X:X'
PRC+8'
FTX+AAG++1E:23:2+BEWARE EMBARGO PAYMENTS:X:X:X:X+EN'
FTX+PMD+++LIMITED LIABILITY+EN'
DOC+380:23:2+43534:1::AA'
DOC+380+43534'
MOA+9:123'
MOA+12:15677'
DTM+137:19970329:102'
DTM+137:19950510:102'
RFF+ON:74482'
RFF+ON:A-7664'
NAD+AB+X:23:9+X:::X+X:X:X:X:X:1+X:X:X:X+X:23:2:X+X+AD'
NAD+DP+507161511110::9'
CUX+2:EUR:11+3:EUR:4+1020.40'
CUX+2:EUR:11+3:USD:4+0.90243'
DTM+134:19970630:102'
DTM+134:20020401:102'
AJT+1'
AJT+4'
MOA+165:475'
MOA+5:8700'
RFF+PL:NOV199602'
RFF+PL:JAN-1995'
DLI+1+7'
DLI+2+55'
MOA+203:500:ARS'
MOA+12:4500'
MOA+9:52000'
PIA+5+X:AA:23:2+X:AA:23:2+X:AA:23:2+X:AA:23:2'
PIA+5+3323456007803:SRV'
AJT+5'
AJT+5'
MOA+5:605'
MOA+5:4920'
RFF+CT:61894870:X'

## Example

---

RFF+PP:6522'

---

GIS+37'

GIS+37'

---

MOA+203:500'

MOA+128:25601'

---

CNT+1:9:H87'

CNT+2:26'

---

AUT+X+X'

AUT+7761'

---

DTM+218:X:2'

DTM+218:200206011200:203'

---

UNT+68+X'

UNT+68+00025'

---

UNZ+1+12345555'

UNZ+5+12345555'

---